

SOURCETRONIC – Quality electronics for service, lab and production

## User Manual

### ST2840X Automatic Transformer Test System



# Contents

<b>Contents</b> .....	<b>1</b>
<b>1 Out of Box Audit</b> .....	<b>8</b>
1.1 Inspect the Package.....	8
1.2 Power Connection.....	8
1.3 Fuse.....	8
1.4 Environment.....	9
1.5 Use of Test Fixture.....	9
1.6 Warm-Up.....	9
1.7 Safety Requirements.....	9
1.7.1 Insulation Resistance.....	9
1.7.2 Insulation Intensity.....	10
1.7.3 Leakage Current.....	10
1.8 Electromagnetic Compatibility Requirements.....	10
1.9 Other Features.....	10
<b>2 Introduction</b> .....	<b>11</b>
2.1 Front Panel.....	11
2.2 Rear Panel.....	14
2.2.1 Rear Panel Description 1.....	14
2.2.2 Rear Panel Description 2.....	15
2.3 Display Areas.....	17
2.4 Main Menu Keys and Their Corresponding Pages.....	17
2.4.1 [DISP].....	17
2.4.2 [SETUP].....	18
2.4.3 [SYSTEM].....	19
2.5 Basic Operation.....	19
2.6 Power ON/OFF.....	19
<b>3 Description of the LCR Function Module</b> .....	<b>20</b>
3.1 <Meas Display>.....	20
3.1.1 Common Measurement Settings.....	20
3.1.2 Measurement Function.....	21
3.1.3 Decimal Point Position.....	21
3.1.4 Display Results of BIN Sorting.....	22
3.1.5 Save Bridge Measurement Results to USB Flash Drive.....	23
3.2 <List Display>.....	23
3.2.1 Save List Sweep Measurement Results to USB Flash Drive.....	24
3.3 <Trace Display>.....	25
3.3.1 Trigger Mode.....	25
3.3.2 Scale.....	25
3.3.3 Max/Min.....	26
3.3.4 Coordinate Format.....	26
3.3.5 Cursor.....	26

3.3.6 Trace.....	27
3.3.7 Number of Sweep Points .....	27
3.3.8 Save Measurement Results to USB Flash Drive .....	28
3.3.9 Other Measurement Results .....	29
3.4 <Meas Setup> .....	30
3.4.1 Measurement Function .....	30
3.4.2 Frequency.....	31
3.4.3 Level .....	31
3.4.4 Speed .....	32
3.4.5 Range .....	33
3.4.6 DC Bias .....	33
3.4.7 Level Monitoring Function.....	34
3.4.8 Trigger Settings.....	35
3.4.9 Average.....	35
3.4.10 Automatic Level Control.....	36
3.4.11 Internal Resistance .....	36
3.4.12 Deviation and Reference .....	36
3.5 <Limit Setup> .....	37
3.5.1 Comparator Function .....	38
3.5.2 Compare Count Function.....	38
3.5.3 Comparator Function Limit Mode.....	38
3.5.4 Compare Parameters .....	38
3.5.5 Deviations and References.....	38
3.5.6 Sorting BIN ON/OFF .....	39
3.5.7 High/Low Limits .....	39
3.6 <List Setup> .....	39
3.6.1 Number of Scan Points .....	40
3.6.2 Trigger Mode.....	40
3.6.3 List Mode .....	40
3.6.4 Difference Mode .....	40
3.6.5 Sweep Condition.....	41
3.6.6 Parameter Functions .....	41
3.6.7 High/Low Limits .....	41
3.6.8 Comparison .....	41
3.6.9 Delay .....	42
3.7 <Trace Setup>.....	42
3.7.1 Common Measurement Settings .....	42
3.7.2 Sweep Parameters .....	43
3.7.3 Spilt Screen .....	43
3.7.4 Number of Scan Points .....	43
3.7.5 Sweep Type .....	43
3.7.6 Trace Mode.....	44
3.7.7 X Format.....	44
3.7.8 Max/Min .....	44
3.7.9 Trace Comparison Configuration .....	44
3.8 User Correction .....	45

3.8.1 Open-Circuit Correction .....	46
3.8.2 Short-Circuit Correction .....	47
3.8.3 Load Correction .....	48
3.8.4 Cable .....	48
3.8.5 Point Frequency Operation .....	48
3.9 Handler Settings.....	49
<b>4 System and File .....</b>	<b>50</b>
4.1 <System Setup> .....	50
4.1.1 Mode Setup .....	50
4.1.2 User Setup .....	51
4.1.3 RS232 Settings.....	52
4.1.4 LAN.....	53
4.1.5 Tools .....	53
4.2 <File> .....	55
4.2.1 USB Drive Performance Management.....	55
4.2.2 Introduction to the Save/Load Function .....	55
4.2.3 Basic Menu Operations of File Management.....	56
4.2.4 Operation Steps for File Management (Save/Load).....	57
<b>5 Execute LCR Measurement and Some Examples.....</b>	<b>58</b>
5.1 Corrections .....	58
5.1.1 Sweep Correction .....	58
5.1.2 Point-Frequency Correction .....	58
5.2 Correct Connection of DUT .....	59
5.3 Eliminate the Influence of Stray Impedance .....	60
5.4 Example: Testing Inductance .....	61
5.4.1 Measurement Settings .....	61
5.4.2 Operation Steps.....	61
5.5 Example: Testing Capacitance by Multi-Frequency List Sweep .....	62
5.5.1 Measurement Settings .....	62
5.5.2 Operation Steps.....	62
5.6 Example: Load Correction.....	63
5.6.1 Measurement Settings .....	63
5.6.2 Operation Steps.....	63
<b>6 Transformer Single-Machine Test .....</b>	<b>65</b>
6.1 Circuit for Transformer Single-Machine Test .....	65
6.1.1 Some Transformer Parameters.....	65
6.1.2 Transformer Single Test Circuit and TURN Test.....	65
6.1.3 Transformer Leakage Inductance Test.....	66
6.1.4 Capacitance Test Between Windings of Transformer .....	66
6.2 <Transformer Single Setup> .....	67
6.2.1 Trigger .....	67
6.2.2 Speed .....	67
6.2.3 Test Mode .....	68

6.2.4 R <sub>SOU</sub> .....	68
6.2.5 Bias Source .....	68
6.2.6 Comp .....	68
6.2.7 Parameter Setup.....	69
6.3 <Single Display> .....	70
6.3.1 Save the Measurement Results of a Single Set of Transformers to the USB Flash Drive .....	70
<b>7 Transformer Auto Scanning Test .....</b>	<b>71</b>
7.1 Introduction to the Scan Measurement Function.....	71
7.2 Install and Connect the Scanning Test System .....	71
7.3 Front Panel of Scanning Box.....	73
7.3.1 Introduction to Each Number on the Front Panel.....	73
7.4 Rear Panel of Scanning Box .....	74
7.4.1 Introduction to Each Number on the Rear Panel .....	74
7.5 Timing Diagram of the Handler Signal.....	74
7.5.1 Distribution and Connection Diagram for Handler.....	75
7.6 Example of Transformer .....	75
7.7 Clear Settings.....	75
7.8 <Transformer ID> .....	76
7.8.1 Transformer ID.....	76
7.8.2 Primary Numbers.....	77
7.8.3 Secondary Numbers .....	77
7.8.4 Rescan Interval.....	77
7.8.5 Scan Disp Mode .....	77
7.8.6 Fail Rescan.....	78
7.8.7 Bias on Delay.....	78
7.8.8 Ignore Nom .....	78
7.8.9 Trigger Delay .....	78
7.8.10 Cylinder CTRL .....	78
7.8.11 Scan Box Mode.....	79
7.8.12 Resistance Source.....	79
7.8.13 Bias Source .....	79
7.9 Trans Pin to Fixture .....	79
7.9.1 Pin-to-Fixture Setup.....	80
7.9.2 Pin Label Setup .....	81
7.10 Pin Setup.....	81
7.10.1 Trans Pin Setup .....	82
7.10.2 Series Pins Setup .....	83
7.10.3 Parallel Pins Setup .....	84
7.11 <Trans Condition> .....	84
7.11.1 Frequency, Voltage, Switch and Scanning Sequence .....	85
7.11.2 Turn Measurement Conditions Setup.....	86
7.11.3 Lx Measurement Conditions Setup .....	89
7.11.4 Lk Measurement Conditions Setup .....	92
7.11.5 Cx Measurement Conditions Setup .....	94

7.11.6 Zx Measurement Conditions Setup .....	98
7.11.7 ACR Measurement Conditions Setup .....	100
7.11.8 DCR Measurement Conditions Setup .....	102
7.11.9 PS Measurement Conditions Setup .....	103
7.11.10 BAL Measurement Conditions Setup .....	105
7.11.11 Handler Mode Function .....	107
7.11.12 Parameter Copy Function .....	107
7.11.13 Statistics Page .....	108
7.12 <Trans Scan> .....	108
7.12.1 Each Display Zone under This Page .....	109
7.12.2 Function Keys on This Page .....	109
7.12.3 PRI Page-Turning Function .....	110
7.12.4 Pin Display Function for Stray Capacitance .....	111
7.12.5 BAL Balance Parameter Display .....	111
7.13 <File> Page of Transformer Scan .....	111
7.13.1 Transformer Scan Setup File (*.t40) .....	111
7.13.2 Operation Steps for File Management .....	112
7.13.3 Transformer Deviation-Deduction .....	113
7.14 Focus .....	114
7.15 Split .....	115
7.16 Frequently Asked Questions About Transformer Scans .....	116
7.16.1 High and Low Limits .....	116
7.16.2 Measurement Item Loss .....	116
7.16.3 Measurement Interruption .....	117
7.16.4 Poor DCR Accuracy .....	117
7.16.5 Poor Lk Accuracy .....	117
7.16.6 Inaccurate TURN .....	117
7.16.7 Unstable Turn .....	118
7.16.8 Difference Between the First and the Second Lx .....	118
7.16.9 Poor Stability of Cx and Zx Open Test Data .....	118
7.16.10 DCR and PS Open Cannot Increase Indefinitely .....	118
7.17 User-Made Test Fixture .....	118
7.17.1 Use ST1801-EXT2A-OUT to Make Test Fixture .....	119
7.17.2 Example of Using ST1801-EXT11A(5.0)-B Pin Signal .....	119
<b>8 Performance and Test .....</b>	<b>120</b>
8.1 Measurement Function .....	120
8.1.1 Parameters .....	120
8.1.2 Measurement Combination .....	120
8.1.3 Mathematical Operation .....	121
8.1.4 Equivalent Mode .....	121
8.1.5 Range .....	121
8.1.6 Trigger Mode .....	121
8.1.7 Delay Time .....	121
8.1.8 Connection Modes of Test Terminals .....	121
8.1.9 Measurement Speed (Frequency $\geq 10$ kHz) .....	121

8.1.10 Average.....	122
8.1.11 Digits Displayed .....	122
8.2 Measurement Signal .....	122
8.2.1 Measurement Signal Frequency .....	122
8.2.2 Signal Mode.....	122
8.2.3 Measurement Signal Level .....	122
8.2.4 Output Impedance .....	122
8.2.5 Monitor for Measurement Signal Level .....	123
8.2.6 Maximum Measurement Display Range .....	123
8.2.7 DC Bias Voltage Source .....	123
8.2.8 2 A Bias Current Source .....	123
8.3 Measurement Accuracy.....	123
8.3.1 Accuracy of $ Z $ , $ Y $ , L, C, R, X, G, B .....	124
8.3.2 Accuracy of D.....	124
8.3.3 Accuracy of Q .....	125
8.3.4 Accuracy of $\Theta$ .....	125
8.3.5 Accuracy of G .....	125
8.3.6 Accuracy of $R_p$ .....	125
8.3.7 Accuracy of $R_s$ .....	126
8.3.8 Accuracy of DCR .....	126
8.3.9 Accuracy of Lk .....	126
8.3.10 Accuracy of Turns Ratio.....	126
8.3.11 Accuracy Factor .....	127
8.4 Performance Testing .....	130
8.4.1 Operating Conditions .....	130
8.4.2 Used Instruments and Devices .....	130
8.4.3 Basic Functionality Check.....	131
8.4.4 Check the Signal Level .....	131
8.4.5 Check the Frequency.....	131
8.4.6 Check the Measurement Accuracy .....	131
<b>9 Command Reference.....</b>	<b>133</b>
9.1 GPIB Common Commands.....	133
9.2 SCPI Command .....	134
9.2.1 DISPlay Subsystem Commands.....	135
9.2.2 FREQuency Subsystem Commands .....	137
9.2.3 VOLTage Subsystem Commands .....	137
9.2.4 CURRent Subsystem Commands .....	138
9.2.5 AMPLitude Subsystem Commands .....	138
9.2.6 OUTPut Subsystem Commands.....	139
9.2.7 BIAS Subsystem Commands.....	140
9.2.8 TRIGger Subsystem Commands .....	141
9.2.9 AMPLitude Auto Level Subsystem Commands.....	143
9.2.10 Output RESister Internal Resistance Subsystem Commands .....	143
9.2.11 FUNCTion Subsystem Commands .....	144
9.2.12 COMParator Subsystem Commands.....	148
9.2.13 LIST Subsystem Commands .....	151

9.2.14 TRACE Subsystem Commands.....	162
9.2.15 Handler Subsystem Commands .....	167
9.2.16 FETCh? Subsystem Commands .....	168
9.2.17 CORRection Subsystem Commands.....	172
9.2.18 Mass MEMory Subsystem Commands.....	179
9.2.19 TRAN Subsystem Commands .....	180
9.2.20 TRS Transformer Scan Subsystem Commands .....	186
9.2.21 SYSTem Subsystem Commands.....	189
9.3 Modbus Commands .....	195
9.3.1 Write Command Format.....	195
9.3.2 Read Command Format .....	196
9.3.3 CRC16 Calculation Method – Look-Up Table Method .....	196
9.3.4 Command Function Comparison Table.....	198
9.4 Examples of Writing Commands .....	209
9.4.1 Examples of LCR Scan Commands .....	209
9.4.2 Examples of Transformer Test Commands .....	209
<b>10 Handler Interface Description.....</b>	<b>210</b>
10.1 BIN Sorting.....	210
10.1.1 Technology Description.....	210
10.1.2 Electrical Features .....	214
10.1.3 Handler Wiring Instructions of BIN Sorting .....	217
10.1.4 Using Operations .....	219
10.2 List Sweep.....	220
10.2.1 List Sweep Sorting Logic .....	220
10.2.2 Technical Description .....	220
10.2.3 Electrical Features .....	223
10.2.4 Wiring Instructions .....	223
10.2.5 Using the List Sweep Comparison.....	224
10.3 Transformer Single-Group Measurement.....	224
10.3.1 Sorting Logic.....	224
10.3.2 Technical Description .....	224
10.3.3 Electrical Features .....	226
10.3.4 Wiring Instructions for Transformer Single-Group Measurement .....	227
10.3.5 Using the Transformer Single-Group Measurement Function.....	228
10.4 Transformer Scan Handler Description .....	228
10.4.1 Technical Description .....	228
10.4.2 Electrical Features .....	231
10.4.3 Wiring Instructions for the Transformer Scan.....	233
10.4.4 Using the Transformer Scan Function .....	235
10.5 Sorting of Scanning Fixtures .....	235



# 1 Out of Box Audit

Thank you for choosing our product – if you have any questions after reading this manual, please feel free to contact Source-tronic. When you receive the product, some inspections are needed before installation.

**Note:** This user manual is intended for ST2840AX, ST2840BX and ST2840NX model instruments (summarized as ST2840 or ST2840X when there is no functional difference). Due to the similarities and differences between these and other models, there may still be occasional mentions in the text of features that do not apply to your device. These can be disregarded.

## 1.1 Inspect the Package

After unpacking, you should first check that the instrument has not been damaged in transit. We do not recommend that you turn on the unit if it is damaged.

Then check it against the packing list. If there is any discrepancy, please contact our company or dealer as soon as possible to protect your rights.

## 1.2 Power Connection

- **Power-Supplying Voltage Range:** 100 ~ 120 V AC or 198 ~ 242 V AC. This depends on the power setup of the rear panel.
- **Power-Supplying Frequency Range:** 47 ~ 63 Hz.
- **Power-Supplying Power Range:** up to 130 VA.
- The power-supplying input phase line L, zero line N, ground lead E must be the same as the power plug of the instrument.
- Although the instrument is able to reduce the interference caused by AC power terminal input, we still recommend it be used in a low-noise environment, or, if this is not possible, with an input filter.

<b>Warning!</b>	
	Make sure the supply line is always reliably grounded; otherwise, leakage may cause injury to the user or damage to the product!

## 1.3 Fuse

Please use the fuse that is pre-installed in the instrument.

<b>Warning!</b>	
	Make sure the fuse position matches your power supply voltage range!

## 1.4 Environment

- Please do not operate the instrument in an environment where it will be subjected to strong vibrations, dust, direct sunlight or corrosive air.
- The normal working temperature is 0 °C ~ 40 °C with a relative humidity of  $\leq 75\%$ , so the instrument should be used under these conditions to guarantee its accuracy.
- There is a heat abstractor on the rear panel to avoid the inner temperature rising – to ensure good ventilation, please do not obstruct the left and right vents.
- Although the instrument is specifically designed to reduce the noise caused by AC power, an environment with low interference is still recommended. If this is not possible, please make sure to use an input filter.
- Please store the instrument at a temperature ranging between 5 °C ~ 40 °C, with a relative humidity of  $< 85\%$  RH, and ensure a non-corrosive environment. If the instrument will not be used for a time, please have it properly packed with its original box or a similar box for storing.
- The instrument, especially the test cables, should be kept as far away as possible from any strong electro-magnetic field, to avoid interference during measurement.

## 1.5 Use of Test Fixture

Please only use the included or additionally purchased original cables and test fixture, as **foreign ones may lead to incorrect measurements**. The test fixture or cable should be kept clean, as well as the DUT pin, to ensure a good connection between the DUT and fixture.

Connect the fixture or cables to the four test terminals **Hcur**, **Hpot**, **Lcur**, **Lpot** on the front panel. For a DUT with shielding, connect it to the ground connection  $\perp$ .

**Note:** If neither test fixture nor cables have been connected, the instrument will display an unstable measurement result.

## 1.6 Warm-Up

- 1) To guarantee an accurate measurement, the instrument should be given a warm-up time of no less than 30 minutes.
- 2) Please do not switch the instrument on and off unnecessarily; this may affect measurement accuracy.

## 1.7 Safety Requirements

The devices of the ST2840 series correspond to protection class I.

### 1.7.1 Insulation Resistance

Under normal operating conditions, the insulation resistance between the power terminal and the device housing must not be less than 50 M $\Omega$ .

In case of increased humidity, the insulation resistance between the voltage terminal and the device housing must not be less than 2 M $\Omega$ .

## 1.7.2 Insulation Intensity

Under normal operating conditions, the device can withstand a voltage of 1.5 kV AC 50 Hz between the mains connection and the device housing for at least 1 minute without voltage drop or flashover.

## 1.7.3 Leakage Current

The leakage current should not exceed 3.5 mA (AC effective value).

## 1.8 Electromagnetic Compatibility Requirements

### According to Directive 2006/95/EC safety requirements

EN 61010-1:2010+A1:2019 Safety requirements for electrical equipment for measurement, control and laboratory use.

### According to Directive 2004/108/EC on electromagnetic compatibility

EN 61326-1:2021 Electromagnetic compatibility requirements for electrical equipment for measurement, control and laboratory use.

- CISPR 11:2015+A1:2016+A2:2019 Radiated and conducted emissions, Group 1, Class A
- EN 61000-4-2:2009 Electrostatic discharge immunity
- EN 61000-4-3:2020 Radiated, radio frequency, electromagnetic field immunity
- EN 61000-4-4:2012 Electrical fast transient/burst immunity
- EN 61000-4-5:2014+A1:2017 Surge immunity for power supply lines
- EN 61000-4-6:2014 Conducted radio frequency immunity
- EN 61000-4-11:2020 Voltage dips and interruptions immunity

**EN 61000-3-2:2019+A1:2021 Harmonic emission for AC power supply lines**

**EN 61000-3-3:2013+A1:2019+A2:2021 Voltage variations, fluctuations and flicker**

## 1.9 Other Features

### Dimensions (W × H × D):

- ST2840AX, ST2840BX: 430 mm × 177 mm × 265 mm
- ST2840NX: 430 mm × 177 mm × 405 mm

### Weight:

- ST2840AX, ST2840BX: approx. 11 kg
- ST2840NX: approx. 17 kg

## 2 Introduction

This chapter details the basic operation features of ST2840X Automatic Transformer Test Systems. Please read this chapter carefully before using your device.

### 2.1 Front Panel

Figure 2-1 shows the front panel of ST2840 series instruments.

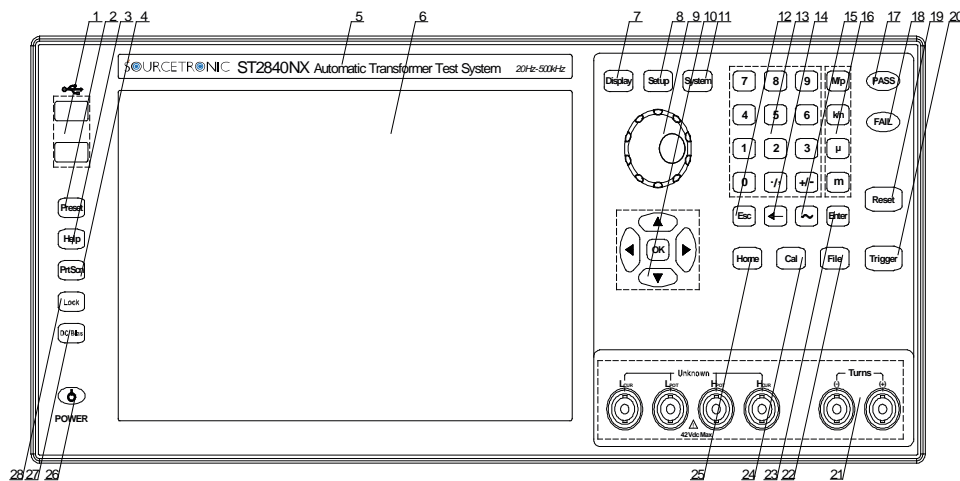

Figure 2-1 Front Panel

#### 1) **USB Host Interface**

ST2840 is equipped with two USB host interfaces, which can be used to connect USB storage to save and load files from, or to connect to devices such as a mouse, keyboard, or scanner. Note that only one USB storage device can be inserted at a time.

#### 2) **[PRESET]**

Press this key to restore the instrument to its factory default settings.

#### 3) **[HELP]**

Upon pressing this key it lights up, and the display will pop up information and operation instructions regarding the element the cursor is located at. If you press the same key again, the light will go out, and the pop-up window will close.

#### 4) **[PRTSCN]**

Press this key to save a screenshot of the current interface to the inserted USB device.

#### 5) **Brand and Model**

Details the brand and model number.

#### 6) **LCD Liquid Crystal Display**

1280x800 color LCD capacitive touch screen, showing the measurement results and settings.

#### 7) **[DISP]**

Press this key to enter the measurement display page of the corresponding function (bridge, transformer measurement, transformer scan, focus scan).

**8) [SETUP]**

Press this key to enter the measurement settings page of the corresponding function (bridge, transformer measurement, transformer scan).

**9) Knob with Confirmation Function**

Move the cursor, select and set parameters. The button in the middle is used to conclude data input and confirm.

**10) Cursor Keys and [OK] Key**

The cursor keys are composed of up (↑), down (↓), left (←) and right (→), which are used to move the cursor between different areas on the LCD display page. When the cursor moves to a certain area, that area will be highlighted on the LCD screen. The middle of the cursor keys is the [OK] key; its function is similar to the [ENTER] key.

**11) [SYSTEM]**

Press this key to access the system setup page.

**12) [ESC]**

"Escape" key.

**13) Numeric Keys**

The numeric keys are composed of the digits [0] to [9], a decimal point [./] and [+/-] keys; they are used to input data directly.

**14) [←]**

Backspace key. Press this key to delete the last digit of the entered value.

**15) [ ~ ]**

This key is used for the continuous input of pins (transformer scan only).

**16) Magnitude Key**

Press this key to input the magnitude of the corresponding parameter.

**17) PASS Indicator**

LED indicator that shows the measurement has concluded successfully.

**18) FAIL Indicator**

LED indicator that shows the measurement has failed.

**19) [RESET]**

While in a list scan or trace scan of the bridge, press this key to pause the scan, and press the [TRIGGER] key to continue the scan from where it previously paused. While in an automatic transformer scan, press the [RESET] key to end the scan; the next trigger will start from the beginning.

**20) [TRIGGER]**

When the trigger mode is set to single mode, press this key to start a measurement cycle.

**21) Test Terminals (UNKNOWN)**

Four-terminal test pairs are used to connect a four-terminal test fixture or cable to the DUT. The terminals are as follows:

- Hcur
- Hpot
- Lpot
- Lcur

**Transformer Secondary Test Terminal (TURNS)**

(+) = Secondary (+) terminal

(-) = Secondary (-) terminal

**22) [FILE]**

Press this key to access the <File Manage> page.

**23) [ENTER]**

Press this key to conclude data input, confirm, and save the data currently displayed in the input line.

**24) [CAL]**

Shortcut keys to perform user calibrations.

**25) [HOME]**

Press this key to switch between the instrument's different functions such as the electric bridge, the transformer single-group test, and the transformer scan.

**26) POWER Switch**

The button is lit up in red while in standby mode and green while powered on. To shut down the instrument, press and hold the power switch.

**27) [DC BIAS]**

This key is used to enable or disable the output of 0 ~ 100 mA,  $\pm 40$  V, 0 ~ 2 A DC bias source. If you press this key, it will light up, indicating that the DC bias output is enabled; if you press the same key again, the light will go out, indicating that the DC bias output is now disabled. In some non-measurement screens where DC bias cannot be applied, pressing this button will have no response.

**28) [LOCK]**

If you press this key, it will light up, indicating that the key functions of the current panel are locked; if you press the same key again, the light will go out, indicating that the keyboard lock state is released. If the password function is set to ON, the correct password must first be entered when unlocking the keyboard. When the instrument is controlled by RS232, USB\_Device, LAN port, etc., the [LOCK] button is also active and lit up. In this case, too, you can unlock by pressing [LOCK] again.

## 2.2 Rear Panel

The rear panels of the different models of ST2840 series instruments vary slightly. The detailed description of the rear panel layout of ST2840AX and ST2840BX will be introduced in 2.2.1 and the detailed description of the rear panel layout of ST2840NX will be introduced in 2.2.2.

### 2.2.1 Rear Panel Description 1

Figure 2-2 briefly describes the rear panel of ST2840AX and ST2840BX.

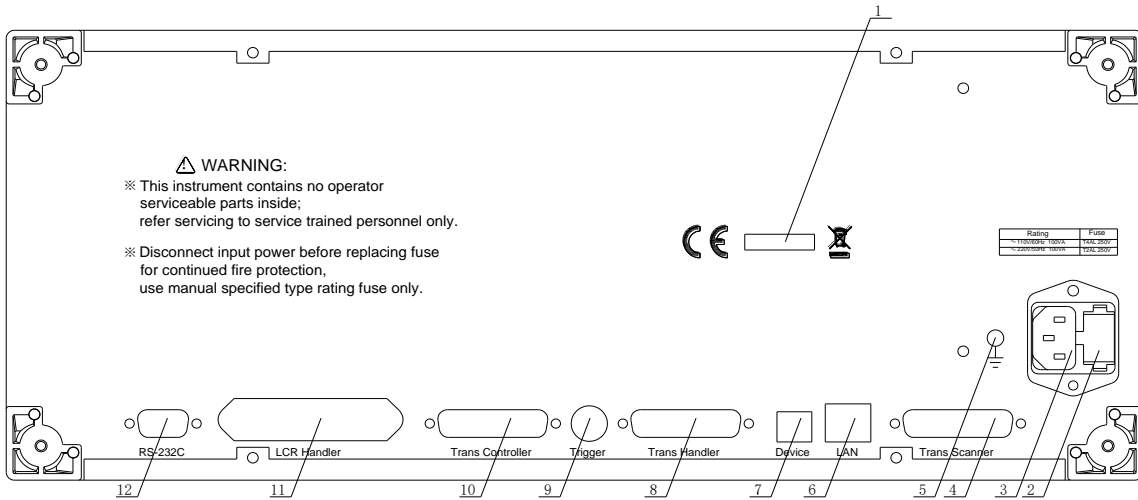

Figure 2-2 Rear Panel of ST2840AX and ST2840BX

- 1) **Nameplate**  
 Contains information regarding production date, instrument number, manufacturer, etc.
- 2) **Fuse Base**  
 This is used to install a power fuse, protect the instrument, and switch 110 V / 220 V by changing the core's direction.
- 3) **Power Socket**  
 Input AC power.

<b>Warning!</b>	
	Before connecting, make sure that the position of the fuse corresponds to the supply voltage used!

- 4) **TransScanner Interface**  
 You can control the transformer scanning box via the TransScanner interface. It is compatible with ST1901 and ST1831 scanning boxes, but different scanning boxes require different connection cables.
- 5) **Ground Terminal**  
 This terminal is connected to the chassis of the instrument. It can be used to protect or shield ground connections.
- 6) **LAN Interface**  
 The LAN interface is used to control and communicate within network systems.
- 7) **USB Device Interface**  
 The USB device interface can be used to communicate with the PC.

**8) TransHandler Interface**

The Handler interface of the transformer scan is used to realize the organized output of the transformer scan results.

**9) Trigger Interface**

External trigger devices such as foot control can be connected here.

**10) TransController Interface**

The Handler extension interface of the transformer scan. When the number of sorting signals of the transformer scanning Handler interface is insufficient, this interface can be used to expand the sorting signal and realize the organized output of the transformer scan results.

**11) LCR Handler Interface**

The Handler interface can realize the organized output of measurement results. This interface is used to sort the results of single-group measurements of the bridge and the transformer.

**12) RS232C Serial Interface**

The serial communication interface is used for online communication with the computer.

## 2.2.2 Rear Panel Description 2

Figure 2-3 briefly describes the rear panel of ST2840NX.

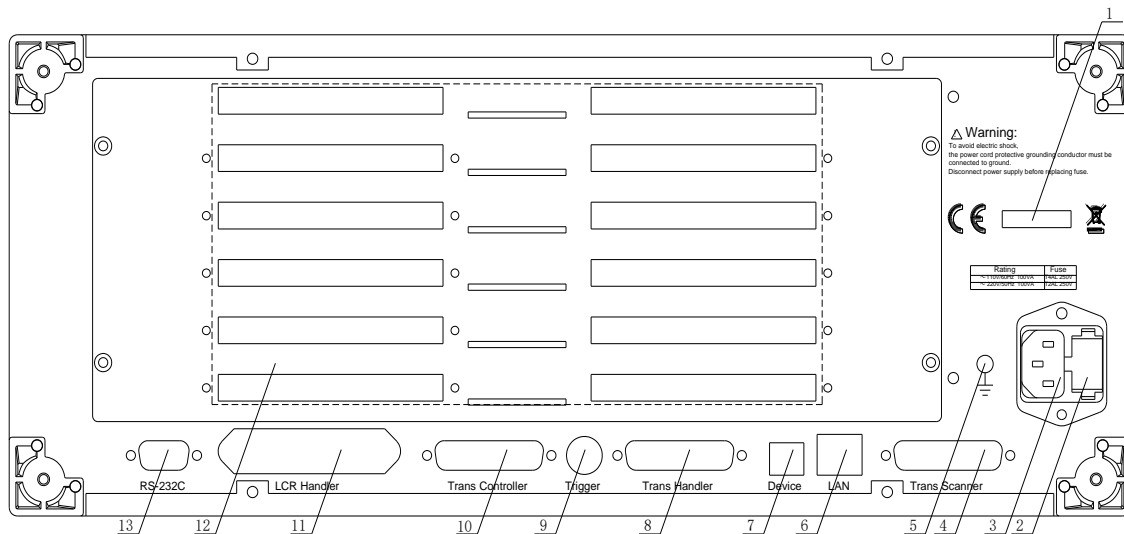

Figure 2-3 Rear Panel of ST2840NX

**1) Nameplate**

Contains information regarding production date, instrument number, manufacturer, etc.

**2) Fuse Base**

This is used to install a power fuse, protect the instrument, and switch 110 V/220 V by changing the core's direction.

**3) Power Socket**

Input AC power.

<b>Warning!</b>	
	Before connecting, make sure that the position of the fuse corresponds to the supply voltage used!



**4) TransScanner Interface**

The TransScanner interface is used to control the transformer scanning box. It is compatible with ST1901 and ST1831 scanning boxes, but note that different scanning boxes will require different connection cables.

**5) Ground Terminal**

This terminal is connected to the chassis of the instrument. It can be used to protect or shield ground connections.

**6) LAN Interface**

The LAN interface is used to control and communicate within network systems.

**7) USB Device Interface**

The USB device interface can be used to communicate with the PC.

**8) TransHandler Interface**

The Handler interface of the transformer scan is used to realize the organized output of the transformer scan results.

**9) Trigger Interface**

External trigger devices such as foot control can be connected here.

**10) TransController Interface**

The Handler extension interface of the transformer scan. When the number of sorting signals of the transformer scanning Handler interface is insufficient, this interface can be used to expand the sorting signal and realize the organized output of the transformer scan results.

**11) LCR Handler Interface**

The Handler interface can realize the organized output of measurement results. This interface is used to sort the results of single-group measurements of the bridge and the transformer.

**12) Scanning Cable Interface**

The scanning cable interface uses a FRC-50P horn socket.

**13) RS232C Serial Interface**

The serial communication interface is used for online communication with the computer.

## 2.3 Display Areas

ST2840 series instruments use a 10.1-inch capacitive touch screen; the content displayed on the screen is divided into the following display areas:

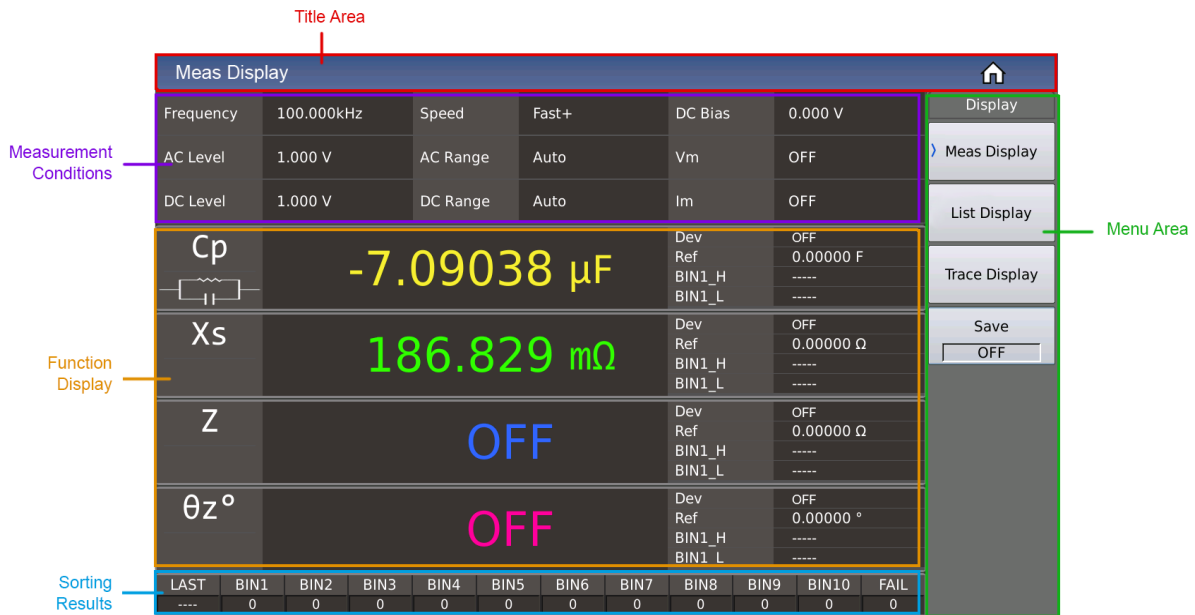

Figure 2-4 Display Areas

The elements shown on this page include:

- Title
- Measurement Conditions (Settings)
- Four-Parameter (Function) Result Display
- Sorting Results
- Menu

## 2.4 Main Menu Keys and Their Corresponding Pages

### 2.4.1 [DISP]

When the LCR function is active, press this key to access the LCR measurement display page. Use the touch screen to select from the following function pages:

- <Meas Display>
- <List Display>
- <Trace Display >
- <Save>

When the transformer measurement function is active, press this key to access the transformer test display page. The following function pages are available here:

- <Save>

When the transformer scan function is active, press this key to access the transformer scan display page. The following function pages are available here:

- **<Pri.>**
- **<Load Std>**
- **<Deviation>**
- **<Speed>**
- **<Test Fail>**
- **<Focus>**
- **<Split>**
- **<Save>**

## 2.4.2 [SETUP]

When the bridge function is active, press this key to access the setting screen of the component test. The following function pages are available here:

- **<Meas Setup>**
- **<Limit Setup>**
- **<List Setup>**
- **<Trace Setup>**
- **<User Corr>**
- **<Handler>**
- **<Tools>**

When the transformer measurement function is active, press this key to enter each setting screen of the transformer test. The following function pages are available here:

- **<Single Setup>**
- **<User Corr>**
- **<Handler>**

When the transformer scan function is active, press this key to enter each setting screen of the transformer scan. The following function pages are available here:

- **<Trans ID>**
- **<Pin To Fixture>**
- **<Pin Setup>**
- **<Condition>**
- **<Copy>**
- **<Handler Mode>**
- **<Stat>**
- **<Tools>**

### 2.4.3 [SYSTEM]

Press this key to enter the system settings homepage, which concerns communication settings, user management settings, and Handler settings. The following function pages are available here:

- <System Info>
- <Message>
- <System Check>
- <License>

## 2.5 Basic Operation

The basic operation principles of ST2840 series instruments are as follows:

- 1) Use the menu keys ([DISP], [SETUP], [SYSTEM]) and soft keys to select pages.
- 2) Use the cursor keys ([←][→][↑][↓]), knob or directly touch the screen to move the cursor between areas on the screen. When the cursor moves to a certain area, that area will be highlighted. This is where you can now configure settings.
- 3) The soft key functions corresponding to the area the cursor is currently located in will be displayed in the soft key area of the screen. Press the desired soft key to select it. The numeric keys, [←], magnitude keys and the [ENTER] key are used for data input. After pressing a numeric key, you can press the confirmation key or [ENTER] to conclude the data input.

## 2.6 Power ON/OFF

Plug in the three-wire power supply.

<b>Caution!</b>	
	Keep the power-supply voltage and frequency conform to above specifications. Power input phase line L, zero line N, ground line E should be the same as that of the instrument!

ST2840 series instruments use soft switches.

After plugging in the three-wire power supply, some indicators on the front panel flash briefly. After a few seconds, the power button lights up red, and any other buttons with LED indications go out.

- **Power On:** Press the power switch in the lower left corner of the front panel to turn on the instrument and display the startup screen. Once the instrument is started, the power button lights up green. The power button of ST2840 series instruments has a memory function.
- **Power Off:** If needed, press and hold the power button in the lower left corner of the front panel to turn off the instrument. Upon doing so, the power button lights up red, and the instrument enters standby mode. If you are planning not to use the instrument for an extended period of time, please disconnect the power cord and store the instrument in an appropriate environment as described in chapter 0.

**Note:** This product series comes with a pre-set default password, which is **2840**. You can of course change the password according to your own needs. For details, please refer to chapter 4.1.2.5 of this user manual.

## 3 Description of the LCR Function Module

### 3.1 <Meas Display>

When the LCR function is active, press [DISP] to access the <Meas Display> page, as shown in the following figure:

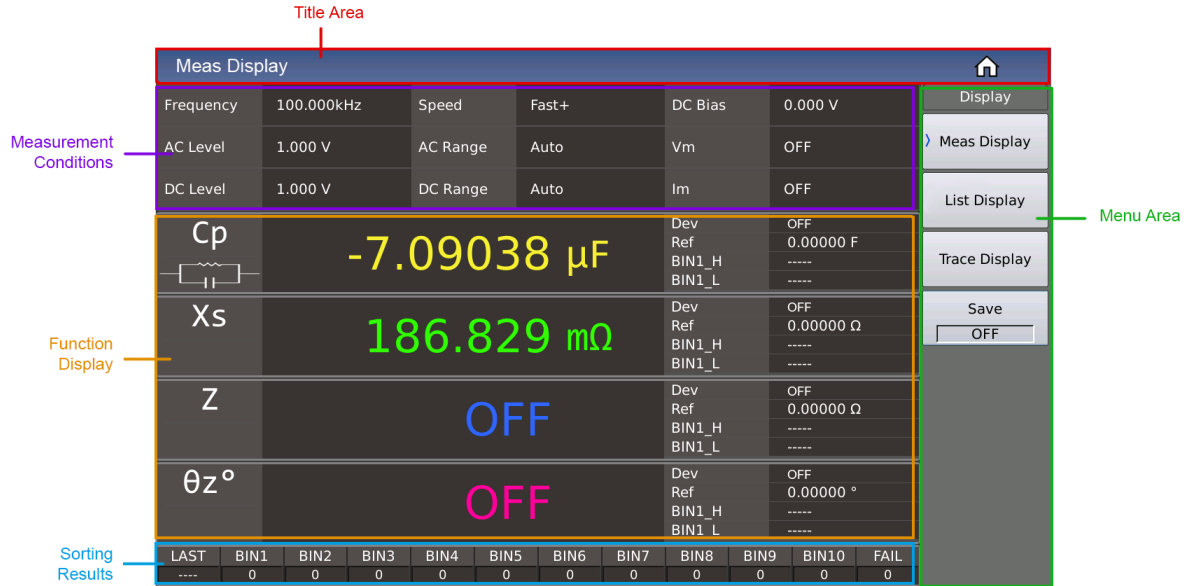

The elements shown on this page include:

- Title
- Measurement Conditions (Settings)
- Four-Parameter (Function) Result Display
- Sorting Results
- Menu
- Status Bar

#### 3.1.1 Common Measurement Settings

There are 9 cursor areas in the measurement settings area of this display page, namely:

- Frequency
- Speed
- DC Bias,
- AC Level
- AC Range
- Vm
- DC Level
- DC Range
- Im

Each of these settings will be described in further detail in the <Meas Setup> chapter of this user manual.

### 3.1.2 Measurement Function

Touch the position of the parameter name in the measurement result area, and you can see the selection menu of the corresponding measurement function in the right menu area. Touch the corresponding selection area of the menu to complete setting the specified parameter.

The menu display is shown in the following figure:

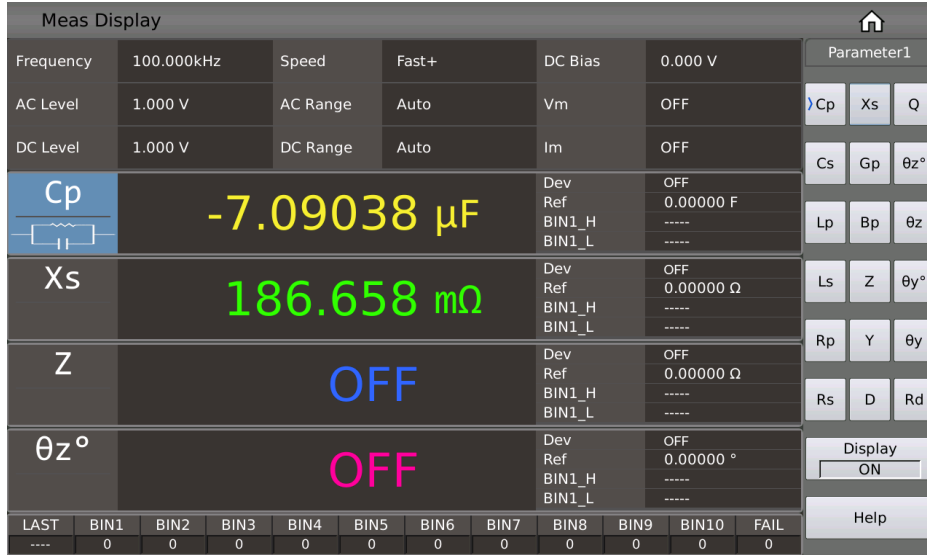

Figure 3-1 Parameter Function Setting

### 3.1.3 Decimal Point Position

The position of the decimal point has a direct relationship with the resolution of the result displayed; this way, the relative stability of the result can also be seen intuitively.

The principle of moving the position is to ensure that the number of digits remains unchanged, with a certain decimal point on the left and right, as shown in the following figure:

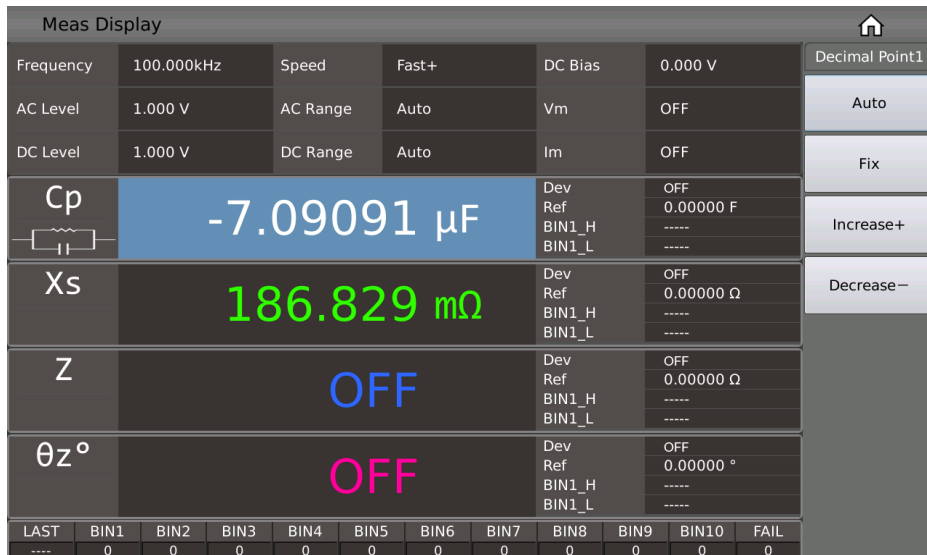

Figure 3-2 Moving the Decimal Point

**Parameter Type:** select from list

- **AUTO:** The default setting, which automatically adjusts the position of the decimal point.
- **FIX:** Lock the current decimal point position while otherwise in auto mode.

- **Increase (+):** Move the decimal point to the left.
- **Decrease (-):** Move the decimal point to the right.

**Note:** In the following cases, the decimal point position lock function will be automatically cancelled and restored to the floating decimal point display state:

- The measurement function is changed;
- The deviation mode is changed.

### 3.1.4 Display Results of BIN Sorting

After touching or moving the cursor to the field that displays sorting results, the corresponding menu will offer some settings for the sorting, such as turning on/off the comparison and counting function, or resetting the count; as shown in the following figure:

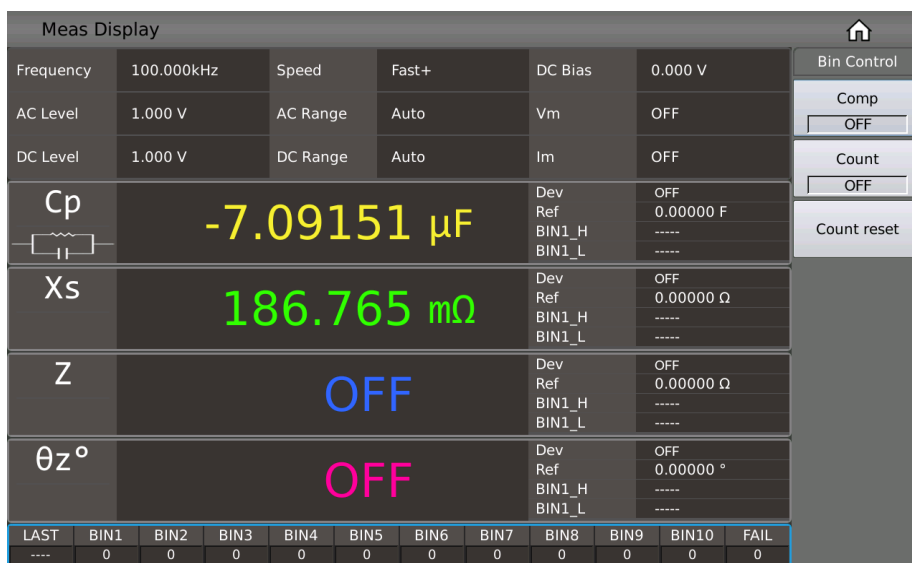

Figure 3-3 Quick Settings for BIN Sorting

#### 3.1.4.1 Comparison Function

ST2840 series instruments come with a built-in comparison function that allows the DUT to be assigned to one of up to eleven sorting bins (BIN1 to BIN10 and BIN OUT). Ten sets of upper and lower limits can be set, and the upper and lower limits of each file containing four parameters can be set independently.

If one or more parameters are not to be included in the comparison, the corresponding upper and lower limits can be cleared.

If the parameters of the DUT that are included in the comparison are all within the range of the BIN limit, the corresponding BIN is found. The results can be output to the automatic test system via the Handler Interface.

These limit settings can only be configured on the <Limit Setup> page.

**Parameter Type:** ON/OFF; the default setting is OFF.

#### 3.1.4.2 BIN Count Function

This function is used to record and display the count value of each BIN.

**Parameter Type:** ON/OFF; the default setting is OFF.

### 3.1.4.3 Count Reset

Restart counting by clearing the count value of the current BIN, so that the BIN count is reset to 0.

### 3.1.5 Save Bridge Measurement Results to USB Flash Drive

Use the USB flash drive to save the bridge measurement results. The results/settings that can be saved include the following:

- Time
- P1
- P2
- P3
- P4
- BIN

(These correspond, in order, to the test time, parameter 1 ~ 4 result, BIN result.)

The operation steps to save your data are as follows:

- 1) Choose [Save]
- 2) "Save path" prompt; default path location: "usb/CSV/" path
- 3) The naming rule of the file name is rx+machine number+date, such as: rx-SN12345678-20210811.csv

## 3.2 <List Display>

On the <List Display> page, you can enter up to 201 points of measurement frequency, as well as measurement level, DC bias, trigger delay, independent functions corresponding to four parameters, four independent parameters, and upper and lower limits for each list sweep measurement point. These measurement points will be automatically scanned and measured, and the measurement results will be compared with their respective limit values.

During the list sweep measurement cycle, the leftmost symbol \* indicates the current sweep measurement point.

Pt	Freq	Level	Bias	Para1	Para2	Para3	Para4	P/F
1	1.00000kHz	1.00000 V	0.00000 A	Cp=-22.9015pF	Cp=-22.9015pF	Cp=-22.9015pF	Cp=-22.9015pF	---
2	1.00000kHz	1.00000 V	0.00000 A	Cp=-22.9015pF	Cp=-22.9015pF	Cp=-22.9015pF	Cp=-22.9015pF	---
3	1.00000kHz	1.00000 V	0.00000 A	Cp=-22.9015pF	Cp=-22.9015pF	Cp=-22.9015pF	Cp=-22.9015pF	---
4	1.00000kHz	1.00000 V	0.00000 A	Cp=-22.9015pF	Cp=-22.9015pF	Cp=-22.9015pF	Cp=-22.9015pF	---
5	1.00000kHz	1.00000 V	0.00000 A	Cp=-22.9015pF	Cp=-22.9015pF	Cp=-22.9015pF	Cp=-22.9015pF	---
6	1.00000kHz	1.00000 V	0.00000 A	Cp=-22.9015pF	Cp=-22.9015pF	Cp=-22.9015pF	Cp=-22.9015pF	---
7	1.00000kHz	1.00000 V	0.00000 A	Cp=-22.9015pF	Cp=-22.9015pF	Cp=-22.9015pF	Cp=-22.9015pF	---
*8	1.00000kHz	1.00000 V	0.00000 A	Cp=-22.9015pF	Cp=-22.9015pF	Cp=-22.9015pF	Cp=-22.9015pF	---

Figure 3-4 List Display

The P/F on the far right (representing PASS/FAIL) is used to indicate the comparison result of the current point:

- No Comparison Display: "---"



- Comparison successfully completed: PASS (green)
- Comparison failed: FAIL (red)

When the difference mode is active, the measurement results of parameters 3 and 4 are not displayed, and the difference calculation result of parameter 1 is displayed, as shown in the following figure:

Pt	Freq	Level	Bias	Para1	Para2	Delta	P/F
1	1.00000kHz	1.000 V	0.000 V				
2	1.00000kHz	1.000 V	0.000 V				
3	1.00000kHz	1.000 V	0.000 V				
4	1.00000kHz	1.000 V	0.000 V				
5	1.00000kHz	1.000 V	0.000 V				
6	1.00000kHz	1.000 V	0.000 V				
7	1.00000kHz	1.000 V	0.000 V				
8	1.00000kHz	1.000 V	0.000 V				

Figure 3-5 List Display Difference Mode

### 3.2.1 Save List Sweep Measurement Results to USB Flash Drive

Use the USB flash drive to save the measurement results. The results/settings that can be saved are as follows:

- Time
- pt
- para1 ~ 4
- P1
- P2
- P3
- P4
- COMP

(These correspond, in order, to test time, point index, 4 parameter function, parameter 1 ~ 4 result, comparison result.)

The operation steps to save your data are as follows:

- 1) Choose [Save]
- 2) "Save path" prompt; default path location: "usb/CSV/" path
- 3) The naming rule of the file name is list+machine number+date, such as: list-SN12345678-20210811.csv

### 3.3 <Trace Display>

Press the menu key [DISP], and then press the soft key [Trace Display] to enter the <Trace Display> page.



Figure 3-6 Trace Display

On this page, each scan will perform automatic measurement of the component under test at 51, 101, 201, 401 or 801 frequency points, in a linear or logarithmic manner and with increasing conditions within the user preset mode range. The instrument displays a dynamic response curve of the main and secondary parameters of the component under test with changes of the mode conditions on the LCD screen.

The result of any point within the scanning range can be read on the screen. Simultaneously, the maximum and minimum measurement values and corresponding measurement settings within the scan range will be displayed.

**Note:** After you have configured the scan settings, you must press the [TRIGGER] key on the front panel to begin the scan. Press the [RESET] key once to pause the measurement, and press it again to reset and rescan.

#### 3.3.1 Trigger Mode

This setting is used to define the trigger mode of the curve; please refer to the corresponding section in the <Meas Setup> chapter for details.

#### 3.3.2 Scale

This setting is used to automatically define the Y-axis coordinate range corresponding to the curve. When it's set to AUTO mode, the Y-axis scale range will be dynamically adjusted with the size range of the measurement result to ensure that the drawn curve is within the display range.

It is recommended that when the DUT is relatively stable, you let the scale automatically select a relatively suitable scale range, and then choose FIX to lock it in. Then you can manually press the up and down direction keys to fine-tune the display range according to your own requirements.

**Parameter Type:** select from list + manual input

- **AUTO:** The scale will adjust automatically.
- **FIX:** The scale is fixed (i.e. will not change on its own), but can still be adjusted manually.

### 3.3.3 Max/Min

See section 3.7.8.

### 3.3.4 Coordinate Format

You can set the format of the abscissa and ordinate of parameters 1 to 4 separately, linear or logarithmic. See section 3.7.7.

### 3.3.5 Cursor

This setting is used to configure the behavior of the cursor (displayed as a red line) on the screen. You can view the measurement results of different parameters under the same scanning condition by turning the knob or using the left and right keys.



Figure 3-7 Cursor Display Effect

#### Setting Options:

Setting	Description
OFF	Cursor is not displayed.
Manual	Manually adjust the cursor (knob; left and right keys).
Para1Min	Automatically track the minimum or maximum value position of parameter 1/2/3/4.
Para1Max	
Para2Min	
Para2Max	
Para3Min	
Para3Max	
Para4Min	
Para4Max	

### 3.3.6 Trace

Via the submenu of the curve button, you can quickly choose the sweep points of the curve, whether to hide or show the parameter on the curve for each of the four parameters, how to split the screen between multiple curves, as well as other related settings.

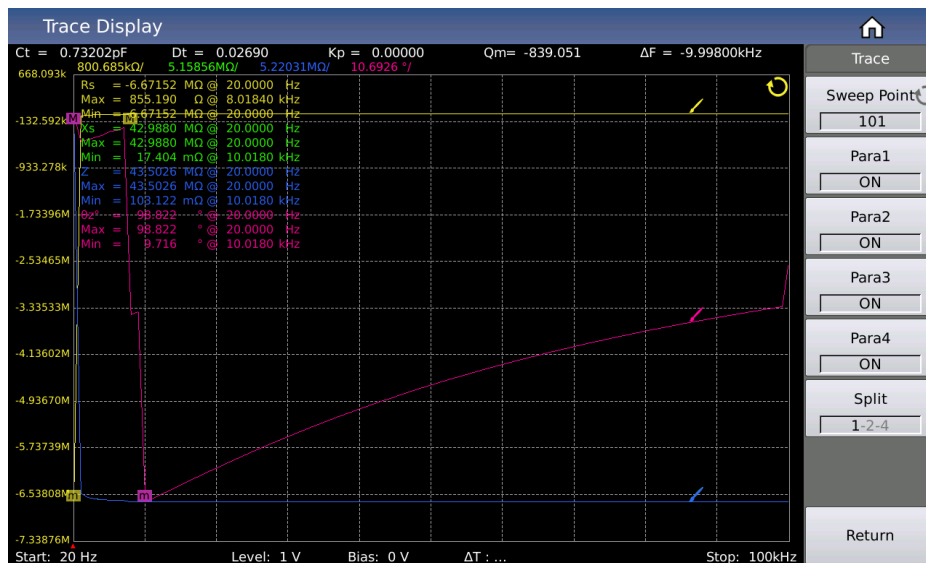

Figure 3-8 Curve Settings Menu

### 3.3.7 Number of Sweep Points

This setting defines the number of points the instrument scans within the start and end conditions. The system lets you choose the number of measurement points between five settings: 51, 101, 201, 401, and 801. The more scan points you select, the more precise the image will be drawn, but the scan will also take longer. The system default setting is **201**.

#### 3.3.7.1 Parameters 1 ~ 4 ON/OFF

These ON/OFF switches are used to include or not include the specified parameter in the displayed curve.

#### 3.3.7.2 Split

This setting lets you choose how to divide the screen to display multiple curves, or not to divide it at all.

**Parameter Type:** select from list

- **1-Split / None:** All curves are displayed in the same drawing window.
- **2-Split:** Four parameters are grouped in pairs and displayed in two drawing windows.
- **4-Split:** Four parameters are all displayed independently in their own separate drawing windows.

Figure 3-9 showcases what the 2-split screen effect looks like, and Figure 3-10 shows the 4-split screen effect.



Figure 3-9 Display Effect of 2-Split Screen

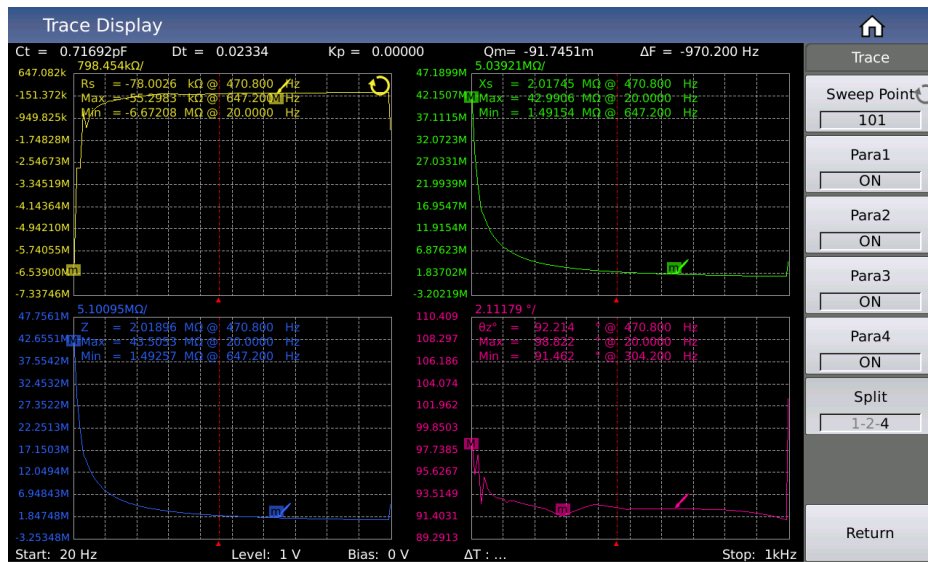

Figure 3-10 Display Effect of 4-Split Screen

### 3.3.8 Save Measurement Results to USB Flash Drive

Use the USB flash drive to save the test results and curve settings. The results/settings that can be saved are as follows:

- Time
- pt
- x
- P1
- P2
- P3
- P4
- COMP

(These correspond, in order, to test time, point index, x-axis size, parameter 1 ~ 4 result.)

The operation steps to save your data are as follows:

- 1) Choose [Save]
- 2) "Save path" prompt; default path location: "usb/CSV/" path
- 3) The naming rule of the file name is rx+machine number+date, such as: trace-SN12345678-20210811.csv

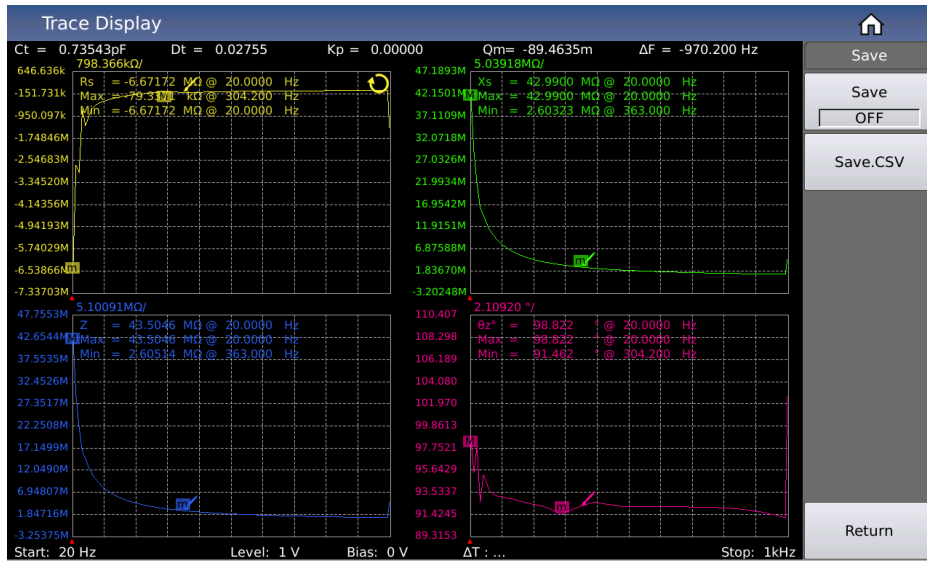

Figure 3-11 Save Settings Menu

Choose whether to continuously save the measurement result data:

- When set to continuous saving, the naming rule of the file name is trace + machine number + date, such as: trace-SN12345678-20210811.csv
- For a single save, the naming rule of the file name is trace-trg + machine number + date, such as: trace-trg-SN12345678-20210811.csv

### 3.3.9 Other Measurement Results

When you select the scan parameters to be frequency and impedance, the instrument will automatically display some specific parameters of the ultrasonic device. These parameters are as follows:

- Static Capacitance Ct: static capacitance value at 1 kHz.
- Static Capacitance Dt: the capacitance loss value at 1 kHz.
- The minimum impedance Z<sub>min</sub> and its corresponding frequency f<sub>s</sub>, (point m on the screen).
- The maximum impedance Z<sub>max</sub> and its corresponding frequency f<sub>p</sub>, (point M on the screen).

$$\Delta F = f_p - f_s$$

$$k_p \approx \sqrt{\frac{f_p - f_s}{f_s}} \times 2.51$$

$$Q_m \approx \frac{f_p^2}{2\pi f_s Z_{\min} C^T (f_p^2 - f_s^2)}$$

## 3.4 <Meas Setup>

Press [SETUP] to access the <Meas Setup> page as shown below:

Meas Setup						Setup
Frequency	1.0000kHz	Speed	Fast	DC Bias	0.000 V	Meas Setup
AC Level	1.000 V	AC Range	Auto	Vm	OFF	Limit Setup
DC Level	1.000 V	DC Range	Auto	Im	OFF	List Setup
Trigger Mode	Single	Average	1	DCI Iso	OFF	Trace Setup
Trigger Delay	0 s	ALC	OFF	Bias Polarity	Auto	User Corr
Step Delay	0 s	Rsou	100Ω	Bias Source	100mA(40V)	Handler
Parameter1	Rs	Deviation1	OFF	Reference1	0.00000 Ω	
Parameter2	Xs	Deviation2	OFF	Reference2	0.00000 Ω	
Parameter3	Z	Deviation3	OFF	Reference3	0.00000 Ω	
Parameter4	θz°	Deviation4	OFF	Reference4	0.00000 °	

Figure 3-12 Measurement Setup Page

### 3.4.1 Measurement Function

**Parameter Type:** select from list

The four parameters of the impedance element can be measured at the same time in one measurement cycle. The measurable parameters are as follows:

Parameter Name	Parameter Meaning	Parameter Name	Parameter Meaning
Cp	Equivalent Parallel Capacitance	Cs	Equivalent Series Capacitance
Lp	Equivalent Parallel Inductance	Ls	Equivalent Series Inductance
Rp	Equivalent Parallel Resistance	Rs	Equivalent Series Resistance
Gp	Conductance	Bp	Susceptance
Z	Absolute Value of Impedance	Y	Absolute Value of Admittance
D	Loss Factor	Q	Quality Factor
θz°	Impedance Degree	θz	Impedance Radian
θy°	Admittance Degree	θy	Admittance Radian
X	Reactance	Rd	DC Resistance

#### Operation Steps to Set the Measurement Function Parameters:

Touch (or use the cursor keys to move the cursor to) the parameter name area corresponding to the measurement result, and select the setting in the soft key area on the right according to the displayed optional parameters.

There is no restriction on the combination of the four parameters, meaning you can choose whichever combination you want.

The display status of the four parameters can each be set independently, that is, when any parameter's display switch is turned off, that parameter's corresponding area on the screen will simply display OFF instead of a measurement result. This function to turn on/off the parameter display can be set in the parameter setting area on the measurement display page.

## 3.4.2 Frequency

**Parameter Type:** numeric input

The maximum range of the measurement frequency depends on instrument model, and the minimum resolution is 0.0001 Hz.

**Note:** The specific models have different frequency ranges they support:

- **ST2840AX, ST2840NX:** 20 Hz ~ 500 kHz
- **ST2840BX:** 20 Hz ~ 2 MHz

**Frequency Range and Measurement Frequency Point:**

Frequency Range (f)	Measurement Frequency Point	Resolution
$20 \text{ Hz} \leq f \leq 99.999 \text{ Hz}$	20.0000 Hz, 20.0001 Hz [...] 99.9999 Hz	0.0001 Hz
$100 \text{ Hz} \leq f \leq 999.9 \text{ Hz}$	100.000 Hz, 100.001 Hz [...] 999.999 Hz	0.001 Hz
$1 \text{ kHz} \leq f \leq 9.999 \text{ kHz}$	1.0000 kHz, 1.00001 kHz [...] 9.99999 kHz	0.01 Hz
$10 \text{ kHz} \leq f \leq 99.99 \text{ kHz}$	10.0000 kHz, 10.0001 kHz [...] 99.9999 kHz	0.1 Hz
$100 \text{ kHz} \leq f \leq 999.9 \text{ kHz}$	100.000 kHz, 100.001 kHz [...] 1 MHz	1 Hz
$1 \text{ MHz} \leq f \leq 2 \text{ MHz}$	1.00000 MHz, 1.00001 MHz [...] 2 MHz	10 Hz

**Operation Steps to Set the Measurement Frequency:**

Directly touch or use the arrow keys to move the cursor to the frequency field. There are two methods to set the frequency:

- Use the number keys to directly input a specific value;
- Use the soft keys (according to the given prompts) to increase/decrease the frequency until you reach the desired value.

## 3.4.3 Level

The measurement level is divided into AC level and DC level.

- AC level is mainly used for AC LCR measurements.
- DC level is mainly used for DC resistance measurements.

### 3.4.3.1 AC Level

**Parameter Type:** numeric input

The measurement level is defined by the effective value of the measurement sine wave signal. The frequency of the sine wave signal is the measurement frequency, which is generated by the internal oscillator of the instrument. You can set either the voltage value or the current value.

**Voltage Level Range:** 5 mV ~ 20 V

**Current Level Range:** 50  $\mu$ A ~ 100 mA

**Note:** There is a linear constraint relationship of internal resistance between the voltage level and the current level. (For example, the current level corresponding to 30  $\Omega$  internal resistance is 166.7 $\mu$ A ~ 66.67 mA, and the current level corresponding to 100  $\Omega$  internal resistance is 50 $\mu$ A ~ 100 mA).

When the measurement function is set to DCR, 30  $\Omega$  or 100  $\Omega$  can be selected as the signal source output impedance.



**Voltage Level and Resolution:**

Voltage Level ( $V_{rms}$ )	Resolution
[5 m, 1)	1 mV
[1, 20]	10 mV <sub>rms</sub>

**Note:** The set measurement current is the output current value when the measured terminal is short-circuited. The set measurement voltage is the output voltage value when the measured terminal is open.

The automatic level control (ALC) function can realize constant voltage or current measurement; it can be enabled on the <Meas Setup> page. When the ALC function is enabled, a \* sign will be displayed after the current level value.

**Operation Steps to Set the Measurement Level:**

- 1) Select the AC level area on the screen. The menu area now displays the option to switch level type and add smaller functions.
- 2) You can modify and adjust your choices according to the menu prompts, or you can use the numeric keys to directly enter the desired value.

**Note:** If you need to switch the measurement level between current and voltage, you must use the menu area on the touch screen.

**3.4.3.2 DC Level**

**Parameter Type:** numeric input

As a measurement condition for DC resistance (RD).

**DC Level Range:**

Internal Resistance	DC Level Range	
30 $\Omega$	0.1 V ~ 2 V	
100 $\Omega$	4 parameters are all RD	0.1 V ~ 20 V
	Other	0.1 V ~ 2 V

**Level Voltage and Resolution:**

Voltage Level ( $V_{rms}$ )	Resolution
[0.1, 1]	1 mV
(1, 20]	10 mV

**3.4.4 Speed**

**Parameter Type:** select from list

The measurement speed is mainly determined by the following factors:

- Integration Time (A/D conversion)
- Average Number of Measurements (the number of measurements used to obtain the average value of the continuous measurement results)

- Measurement Delay (the time that passes between the trigger impulse until the measurement begins)
- Display Time of Measurement Results

Generally speaking, when measuring slowly, the measurement result will be more stable and accurate. You can choose between four measurement speeds.

**Setting Options:**

- FAST+
- FAST
- MED
- SLOW

See the description in section 8.1.9 for further details.

### 3.4.5 Range

The range is divided into AC range and DC range. The AC range is used to measure AC LCR parameters, and the DC range is used to measure DC resistance.

**Parameter Type:** select from list

The measurement range is selected according to the impedance value of the LCR component under test.

- **AC Measurement Range:** 0.1  $\Omega$ , 1  $\Omega$ , 10  $\Omega$ , 20  $\Omega$ , 50  $\Omega$ , 100  $\Omega$ , 200  $\Omega$ , 500  $\Omega$ , 1 k $\Omega$ , 2 k $\Omega$ , 5 k $\Omega$ , 10 k $\Omega$ , 20 k $\Omega$ , 50 k $\Omega$ , 100 k $\Omega$ .
- **DC Measurement Range:** 0.1  $\Omega$ , 1  $\Omega$ , 10  $\Omega$ , 20  $\Omega$ , 50  $\Omega$ , 100  $\Omega$ , 200  $\Omega$ , 500  $\Omega$ , 1 k $\Omega$ , 2 k $\Omega$ , 5 k $\Omega$ , 10 k $\Omega$ , 20 k $\Omega$ , 50 k $\Omega$ , 100 k $\Omega$ .

**Operation Steps to Set the Measurement Range:**

- 1) Use the cursor keys to move the cursor to the Range field. The screen will display the following soft keys:
  - **AUTO:** This soft key is used to set the range to AUTO (automatic) mode.
  - **HOLD:** This soft key is used to switch the range from AUTO mode to HOLD mode. When the range is set to HOLD mode, the range will be locked in the currently selected measurement range, which will be displayed in the range field of the screen.
  - **Increase (+):** This soft key is used to increase the range in HOLD mode.
  - **Decrease (-):** This soft key is used to decrease the range in HOLD mode.
- 2) Use the soft keys to set the measurement range.

### 3.4.6 DC Bias

**Parameter Type:** numeric input

This involves selecting bias source and type, setting the digital size range, as well as other related settings.

### 3.4.6.1 Bias Source

ST2840 series instruments come equipped with two types of internal bias source or external biases for selection. The corresponding options and input ranges are as follows:

Bias Source	Bias Type	Input Range
Internal 100 mA (Voltage, current, internal resistance are related to Ohm's law.)	Voltage	-40 ~ 40 V
	Current	-100 ~ 100 mA
Internal 2 A	Current	0 ~ 2 A
External ST1778	Current	0 ~ 120 A (Determined by the external bias source)

### 3.4.6.2 Bias Type

When you are using the internal bias source of 100 mA, you can choose between the bias current mode or the bias voltage mode, and the maximum setting size is restricted by the relationship of the internal resistance.

**Parameter Type:** numeric input

Press the [DC BIAS] key on the front panel to enable the set DC bias output. When the DC bias output is enabled, the [DC BIAS] key will be lit.

### 3.4.6.3 DC Isolation

**Parameter Type:** ON/OFF

The bias current isolation function can prevent the influence of DC current on the measurement input circuit. The function can be turned on or off using the ISO domain. On the single measurement page (measurement display), the ISO switch control is determined by your individual settings. During list sweep and trace sweep measurements, when the current is above a certain level, it is automatically controlled by the set current.

**Note:** After the bias current isolation function is turned on, it will affect the test accuracy. Therefore, when measuring high-impedance components under low frequency and small bias current conditions, the bias current isolation function should be set to OFF.

### 3.4.6.4 Bias Polarity

Fixed or automatic mode.

## 3.4.7 Level Monitoring Function

The level monitoring function allows you to monitor the actual voltage across the DUT or the actual voltage and current values flowing through the DUT.

The voltage monitoring value is displayed in the Vm monitoring field on the <Meas Disp> page; the current monitoring value is displayed in the Im monitoring field on the <Meas Disp> page.

**Parameter Type:** ON/OFF

**Note:** The calibration function of the instrument has an influence on the level monitoring function. Therefore, when the correction data changes, the level monitoring value also changes. Turning on or off the open-circuit/short-circuit/load correction functions will also affect the level monitoring value.

### 3.4.8 Trigger Settings

This outlines the trigger mode, trigger delay, and step delay settings. Schematic diagram of trigger delay time and step delay time:

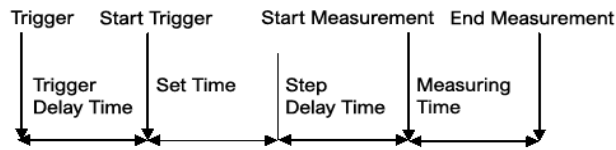

**Note:** The set time in the figure is the preparation time for the signal source control of the instrument measurement, range switching, etc.

#### 3.4.8.1 Trigger Mode

**Parameter Type:** select from list

The choice of trigger mode determines the trigger condition of the instrument test. This series provides two different trigger modes to choose from.

- **Continuous Trigger Mode:** continuously repeating measurements
- **Single Trigger Mode:** Each time you press the [TRIGGER] key on the front panel, and each time the Handler Interface receives a positive pulse trigger signal or remote command, a trigger command is given, and a single measurement is taken.

**Note:** If, during measuring, another trigger signal is received, this signal will be ignored. Therefore, the trigger signal needs to be sent again after the measurement is completed. When you need to trigger from the optional Handler Interface, set the trigger mode to single trigger mode.

#### 3.4.8.2 Trigger Delay

**Parameter Type:** numeric input

Trigger delay refers to the delay time from when the instrument is triggered to the start of measurement. The trigger delay time setting range is 0 s ~ 60 s, and the minimum resolution is 1 ms. This function can be particularly useful when the instrument is used in an automatic test system. When the instrument is triggered by the Handler Interface, the trigger delay time can ensure reliable contact between the DUT and the test terminal.

#### 3.4.8.3 Step Delay

**Parameter Type:** numeric input

The step delay is the delay time from the output of the measurement signal to each measurement. The step delay time setting range is 0 s ~ 60 s, and the minimum resolution is 1 ms.

**Note:** There are *two* step delays in the RD measurement (because the voltage in the positive and negative directions needs to be added), so there are two measurement cycles. This means the *total* step delay time is twice the time you set here.

### 3.4.9 Average

**Parameter Type:** numeric input

The average function calculates the average of the results of 2 or more tests. The number of averages can be set from 1 ~ 255, and the minimum resolution is 1.

### 3.4.10 Automatic Level Control

The automatic level control function can adjust the actual measurement level (the voltage at both ends of the DUT or the current flowing through the DUT) to the set measurement level value as much as possible. Using this function can ensure that the test voltage or current at both ends of the DUT remains constant.

**Parameter Type:** ON/OFF

**Note:** When the constant level function is active, if the level setting exceeds the above range, the constant level function will be automatically set to OFF. The currently set level value is generally regarded as a non-constant level value.

### 3.4.11 Internal Resistance

When using the internal 100 mA bias current, the output of the signal source has an output resistance, and the output signals of other bias current modes are not output through this internal resistance.

**Parameter Type:** select from list

The internal resistance can be selected from 100  $\Omega$  or 30  $\Omega$ , and the default is 100  $\Omega$ . When measuring inductance, in order to compare data with other types of testers, it is necessary to ensure the same output resistance value.

**Note:** When using the internal 100 mA bias current output, 100  $\Omega$  internal resistance is recommended by default.

### 3.4.12 Deviation and Reference

#### 3.4.12.1 Deviation Mode

**Parameter Type:** select from list

The deviation measurement function can make the deviation value (instead of real test value) be directly displayed on the screen. The deviation value is equivalent to the real test value subtracting the pre-set reference value. This function brings great convenience to observe variations of component parameters with temperature, frequency, bias.

The instrument provides two deviation test modes as below:

**$\Delta$  (Absolute Deviation Mode):** The deviation currently displayed is the difference between the test value of the DUT and the preset reference value. The formula of calculating  $\Delta_{ABS}$  is as below:

$$\Delta = X - Y$$

Where...

- X is the test value of DUT.
- Y is the preset reference value.

**$\Delta\%$  (Percentage Deviation Mode):** The deviation currently displayed is the percentage of the difference between the test value of DUT and the preset reference value divided by the reference value. Its calculating formula is as below:

$$\Delta\% = (X - Y) / Y \times 100 [\%]$$

Where...

- X is the test value of DUT.
- Y is the preset reference value.

If the reference value is 0, the measurement result shows Inf.

### 3.4.12.2 Deviation Reference Value

**Parameter Type:** numeric input

This is the reference value used to calculate the deviation of the measurement result.

### 3.4.12.3 Reference Value Setting Method

**Parameter Type:** select from list

**Setting Options:**

- Regular numerical input
- Automatic recording after measurement: Select the measurement function in the corresponding menu area of the reference, a test will be executed, and the measurement result will be recorded here as the parameter value.

## 3.5 <Limit Setup>

Press the menu key [SETUP], and then press the [Limit Setup] soft key to enter the <Limit Setup> page.

Limit Setup							Setup
Comp	OFF	Para	Cp	Xs	Z	$\theta z^\circ$	Setup
Count	OFF	Dev	OFF	OFF	OFF	OFF	Meas Setup
Mode	Tol	Ref	0.00000 F	0.00000 $\Omega$	0.00000 $\Omega$	0.00000 $^\circ$	Limit Setup
BIN1	OFF	Low	----	----	----	----	List Setup
		High	----	----	----	----	Trace Setup
BIN2	OFF	Low	----	----	----	----	User Corr
		High	----	----	----	----	Handler
BIN3	OFF	Low	----	----	----	----	
		High	----	----	----	----	
BIN4	OFF	Low	----	----	----	----	
		High	----	----	----	----	
BIN5	OFF	Low	----	----	----	----	
		High	----	----	----	----	
BIN6	OFF	Low	----	----	----	----	
		High	----	----	----	----	
BIN7	OFF	Low	----	----	----	----	
		High	----	----	----	----	
BIN8	OFF	Low	----	----	----	----	
		High	----	----	----	----	
BIN9	OFF	Low	----	----	----	----	
		High	----	----	----	----	
BIN10	OFF	Low	----	----	----	----	
		High	----	----	----	----	

Figure 3-13 Limit Setup Page

The comparator function of the instrument can be set on this page.

10 BIN limits can be set, and the measured results can be sorted into up to 11 BINs (BIN1 to BIN10 and BIN OUT).

- Comparator Function
- Comparator Count Function
- Comparator Function Limit Mode
- Parameters to Compare
- Deviations
- References (reference value in deviation mode, namely nominal value)
- Sorting BINs ON/OFF
- Lower Limit Value of Each BIN (Low)
- Upper Limit Value of Each BIN (High)

### 3.5.1 Comparator Function

Parameter Type: ON/OFF

### 3.5.2 Compare Count Function

Parameter Type: ON/OFF

### 3.5.3 Comparator Function Limit Mode

The comparison function provides the two parameter limit setting modes, as shown in the figure below.

Parameter Type: select from list

- **Sequential Mode:** In sequential mode, the test value range is used as the comparison limit value. The comparison limit value must be set in ascending order.
- **Tolerance Mode:** In tolerance mode, set the deviation value from the nominal value (the nominal value is set in the nominal field) as the comparison limit value. There are two ways of deviation: one is the percentage deviation, and the other is the absolute deviation.

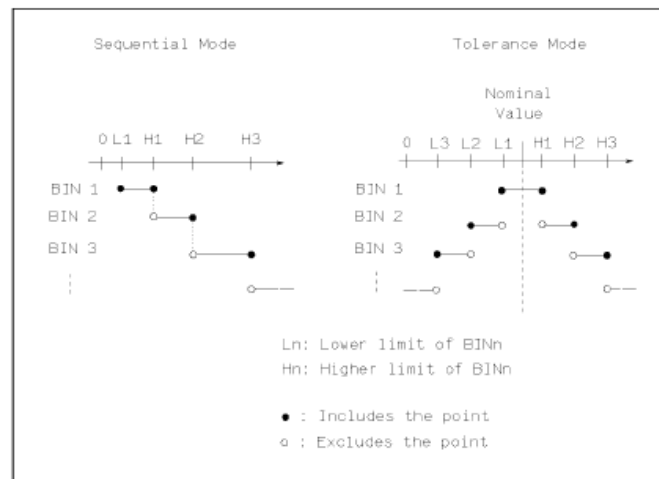

Figure 3-14 Sequential Mode and Tolerance Mode

**Note:** When setting the limit value in tolerance mode, the error range must be set from small to large. If the error range set by BIN1 is the largest, then all the measured parts will be sorted into BIN1 file.

In tolerance mode, the lower limit does not have to be less than the nominal value, and the upper limit does not have to be greater than the nominal value. The limits of each BIN can be discontinuous or overlapping.

### 3.5.4 Compare Parameters

Comparing parameters adopt the four measurement parameters; the sorting parameters can be modified on the measurement display page or the measurement setting page.

### 3.5.5 Deviations and References

Refer to the setting of the deviation and reference on the measurement settings page; the meaning of the parameter here is exactly the same.

### 3.5.6 Sorting BIN ON/OFF

**Parameter Type:** ON/OFF

When the corresponding sorting BIN is OFF, the sorting process will skip this sorting limit comparison.

### 3.5.7 High/Low Limits

As the main basis for parameter comparison.

If the upper and lower limits of the corresponding BIN are not set, it indicates that the parameter in the corresponding BIN does not participate in the comparison, that is, the measurement result does not affect the comparison result.

**Parameter Type:** numeric input

**Note:** When only the upper or only the lower limit is set, it is regarded as a unilateral comparison.

## 3.6 <List Setup>

Press [SETUP] and then [List Setup] to enter into the <List Setup> page as shown below.

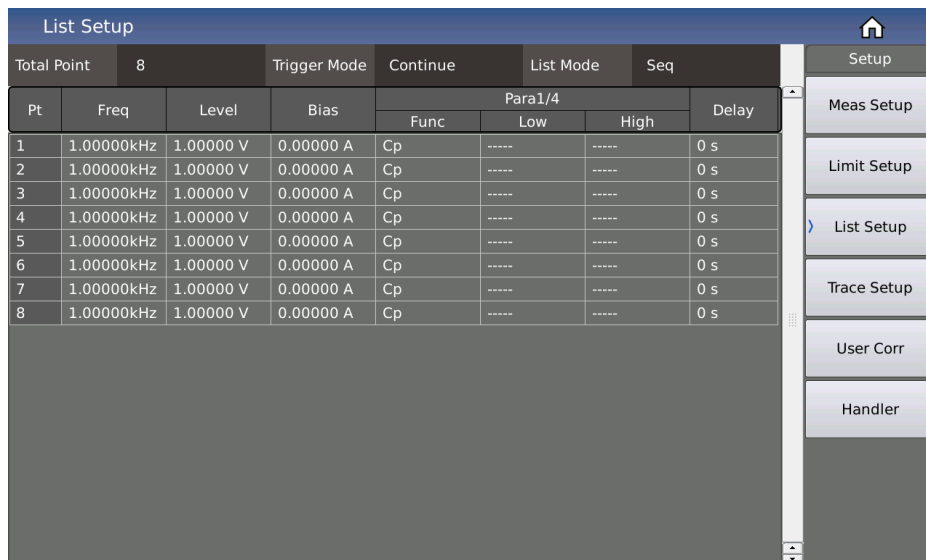

List Setup								Setup
Total Point	8			Trigger Mode	Continue	List Mode	Seq	Meas Setup
Pt	Freq	Level	Bias	Func	Para1/4		Delay	Limit Setup
					Low	High		
1	1.0000kHz	1.00000 V	0.00000 A	Cp	-----	-----	0 s	List Setup
2	1.0000kHz	1.00000 V	0.00000 A	Cp	-----	-----	0 s	Trace Setup
3	1.0000kHz	1.00000 V	0.00000 A	Cp	-----	-----	0 s	User Corr
4	1.0000kHz	1.00000 V	0.00000 A	Cp	-----	-----	0 s	Handler
5	1.0000kHz	1.00000 V	0.00000 A	Cp	-----	-----	0 s	
6	1.0000kHz	1.00000 V	0.00000 A	Cp	-----	-----	0 s	
7	1.0000kHz	1.00000 V	0.00000 A	Cp	-----	-----	0 s	
8	1.0000kHz	1.00000 V	0.00000 A	Cp	-----	-----	0 s	

Figure 3-15 List Setup

The list sweep function can perform auto sweep test for the measurement frequency, level or bias voltage of 201 points.

On the <List Setup> page, the following list sweep parameters can be set:

- Total Points
- Trigger Mode
- List Mode (sweep mode)
- Comparison
- Difference Mode
- Sweep Condition (frequency [Hz], level [V], level [I], bias [V], bias [I])
- Parameter Function
- High/Low Limit (HIGH, LOW)
- Single Point Delay (DELAY[s])



### 3.6.1 Number of Scan Points

Set the number of points to be scanned for list sweep; the value range is 1 ~ 201.

### 3.6.2 Trigger Mode

This is the same as the trigger mode on the measurement settings page. After the list sweep is triggered normally, the user can interrupt the list sweep process by pressing the [RESET] button:

- Press [RESET] once to pause, and continue scanning at the current point at the next trigger;
- Press [RESET] twice to reset, and restart scanning from the first point at the next trigger.

### 3.6.3 List Mode

Set the list sweep mode, choosing between sequential mode or single-step mode.

**Parameter Type:** select from list

- **Sequential Mode:** Upon receiving a trigger signal, the instrument will sweep sequentially from the first to the last point.
- **Single-Step Mode:** Upon receiving a trigger signal, only one point can be tested at a time.

**Note:** The effect of the list mode is mainly reflected in the single-step mode. When in sequential mode, the test process of the two modes will be visually different.

### 3.6.4 Difference Mode

In the list scan of parameter 1, the scan point n (range 1 ~ 201) is compared with the parameter 1 reading of scan point 1 or scan point 2 by difference.

When the comparison function (section 3.6.8) is enabled and the difference mode is **disabled**, the list display page is as shown in Figure 3-4 in section 3.2, and the PASS/FAIL result output is based on the upper and lower limit comparison results of the measured data of parameters 1 to 4.

When the comparison function (section 3.6.8) is enabled and the difference mode is **enabled**, the list display page is as described at the end of section 3.2 and the difference calculation result is displayed at the same time.

The PASS/FAIL result is then output based on the comparison result of the difference calculation result.

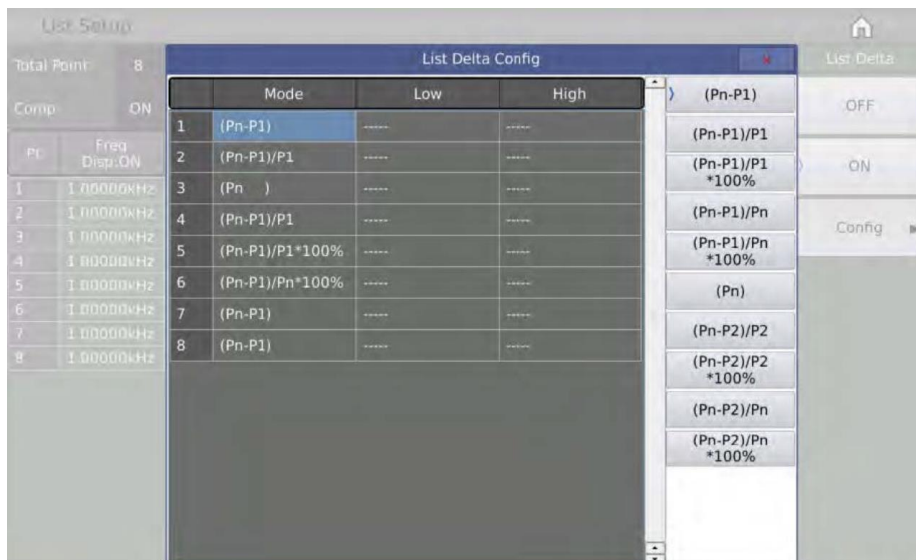

Figure 3-16 Difference Mode Configuration

### 3.6.5 Sweep Condition

Frequency, level, and bias can be set independently, and can also be quickly set to make one of the conditions remaining relatively regular.

If you are only concerned about the impact of one condition change on the DUT, you can quickly set other measurement conditions to the same result, such as a linear change in frequency, and a fixed level and bias.

Regarding the frequency, level and bias in the sweep condition, you can choose whether to display it on the test page, touch the title area corresponding to the parameter, and then select ON or OFF on the corresponding menu.

### 3.6.6 Parameter Functions

Four parameter functions, all of which can be set independently, and can also be quickly set to make one of the conditions relatively consistent.

Since the upper and lower limits involved in setting the limits using the 4-parameter setting method would result in excessively long panning effects, a parameter display menu is used to achieve the function of setting the upper and lower limits of one of the parameters. The parameter display menu here is only used to select the parameter index that is currently being set, and has no direct relationship to whether the parameter is being measured.

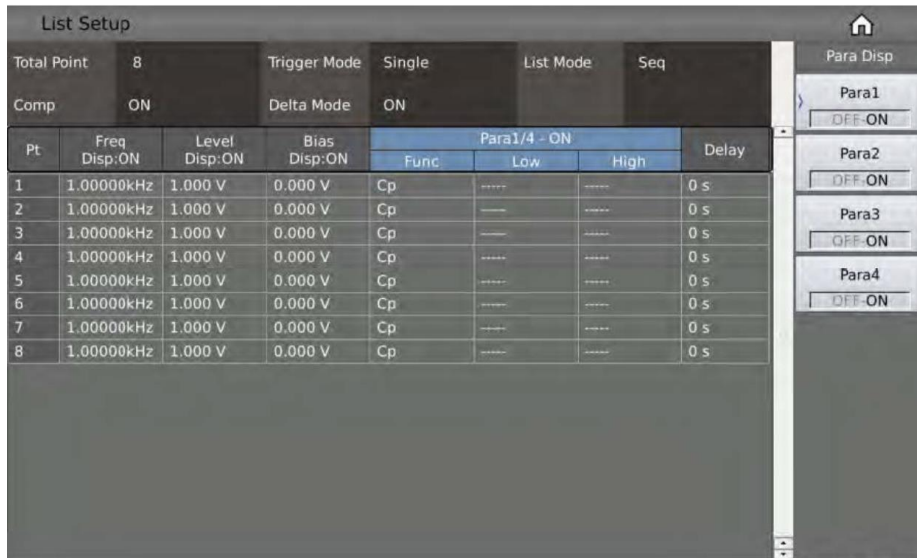

Figure 3-17 List Parameter Display Menu

### 3.6.7 High/Low Limits

The upper and lower limits of the parameters can be set independently, and can also be set quickly to make the settings have a specific ratio.

### 3.6.8 Comparison

The upper and lower limits of the parameters are used as the main basis for comparing the parameters. When differential mode is enabled, the P/F result is displayed by comparing the upper and lower limits of the difference of parameter 1. Parameter 2 is used only to display the measurement result and does not participate in the comparison.

**Parameter Type:** ON/OFF

### 3.6.9 Delay

The delay parameter indicates the delay time from the completion of each sweep step measurement to the next sweep measurement. It is mainly used to connect an external bias source (such as ST1778) to adapt to the delay time setting required by the external bias current source.

**Note:** The delay here can be accumulated with the delay in the measurement setting interface.

## 3.7 <Trace Setup>

Press [SETUP] and then [Trace Setup] to enter into the <Trace Setup> page.

Trace Setup						Setup
Frequency	100.000kHz	Speed	Fast+	DC Bias	0.000 V	Meas Setup
AC Level	1.000 V	AC Range	Auto	Split	4	Limit Setup
DC Level	1.000 V	DC Range	Auto	Sweep Point	101	List Setup
Trigger Mode	Continue	Sweep Type	Freq[Hz]	Trace Mode	Seq	Trace Setup
Trigger Delay	0 s	Start	20.0000	X Format	Linear	User Corr
Step Delay	0 s	Stop	1.00000k	Max-Min	ON	Handler
Parameter1	Rs	Min1	-7.33663M	Max1	646.932k	
Parameter2	Xs	Min2	-3.20232M	Max2	47.1887M	
Parameter3	Z	Min3	-3.25359M	Max3	47.7547M	
Parameter4	$\theta z^\circ$	Min4	89.2958	Max4	110.409	

Figure 3-18 Trace Setup

This display function page is used to complete the setting of trace sweep measurement parameters, including...

- Split Screen
- Sweep Points
- Sweep Type
- Start Condition
- Stop Condition
- Trace Mode
- X Format
- Max/Min Values
- Parameters
- Y Display Range, etc.

### 3.7.1 Common Measurement Settings

Frequency, level, speed, range, offset, trigger, delay, etc. are all common measurement conditions, and their meaning and setting method are exactly the same as the description on the measurement settings page.

### 3.7.2 Sweep Parameters

The 4 sweep parameters are used to specify the result parameters of the trace sweep, that is, to draw the measurement results under certain conditions into a curve.

The sweep parameters and the conventional component 4 test parameters are independent of each other and not directly related. Optional parameters can be selected, except for RD. The sweep parameters correspond to 4 curves; each curve has independent display switch, display scale and independent ordinate scale, but share the same abscissa scale.

### 3.7.3 Spilt Screen

For the curve display effect, 3 kinds of split screen display are available:

**Parameter Type:** select from list

- **1-Split / None:** All four curves are displayed in the same drawing window.
- **2-Split:** The four curves are grouped in pairs and displayed in the corresponding drawing window.
- **4-Split:** The four curves are displayed independently in their respective drawing windows.

### 3.7.4 Number of Scan Points

This is the number of points to be scanned. There are five groups of 51, 101, 201, 401, 801 to choose from.

### 3.7.5 Sweep Type

The sweep type is mainly used to set the conditions of the trace sweep, that is, to plot the measurement results according to the selected condition parameters, so it involves the type of condition parameters, the start size and the stop size of the condition change.

Set the main conditions corresponding to the sweep curve, namely frequency [Hz], level [V], level [A], bias [V], bias [A]:

Sweep Type	Description	Linear	Logarithmic
Freq [Hz]	The condition changes within the specified interval (between start and stop), and record the corresponding parameter results after changing in a linear or logarithmic relationship	√	√
Level [V]		√	×
Level [A]		√	×
Bias [V]		√	×
Bias [A]		√	×

#### 3.7.5.1 Starting Conditions

After selecting the sweep type, set the start size and stop size of the corresponding conditions; that is, the start and stop points of the trace sweep.

### 3.7.6 Trace Mode

Set the trace sweep mode to either sequential mode or single-step mode.

**Parameter Type:** select from list

- **Sequential Mode:** Upon receiving a trigger signal, the instrument will sweep sequentially from the first to the last point.
- **Single-Step Mode:** Upon receiving a trigger signal, only one point can be tested at a time.

**Note:** The effect of the trace mode is mainly reflected in single-step mode. If the instrument is in sequential mode, the test process of the two modes will be visually different.

### 3.7.7 X Format

This area is used to change the coordinate mode of sweep, mainly for the abscissa.

**Parameter Type:** select from list

- **Linear:** The sweep condition parameters are linearly distributed within the start and stop ranges.
- **Logarithmic:** The sweep condition parameters are distributed in a logarithmic manner with the base 10 within the start and stop ranges.

**Note:** For the scan frequency, the logarithmic mode is the only valid option.

### 3.7.8 Max/Min

**Parameter Type:** ON/OFF

- **ON:** Display the maximum and minimum values of the parameter curve results
- **OFF:** Do not display the maximum and minimum values of the parameter curve results

### 3.7.9 Trace Comparison Configuration

Provides a comparison function for curve data that includes a range comparison of the entire parameter, a comparison of the minimum and maximum values of the specified curve, a comparison of the abscissa corresponding to the minimum and maximum values, and a comparison of the relevant piezoelectric test parameters.

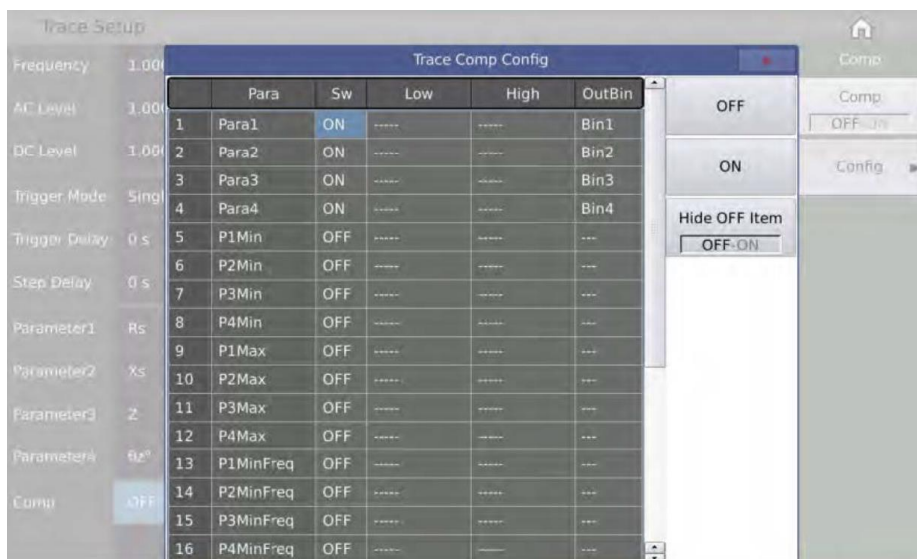

Figure 3-19 Trace Comparison Configuration

### 3.8 User Correction

Ten user Pt are provided on the <User Corr> page. In the Freq domain, you can set whether the calibration data of the corresponding point is turned on. After turning on, manually enter the frequency corresponding to the calibration, and then use the soft key [Open] to execute open-circuit correction, short-circuit correction, and load correction for the set frequency.

Press the menu key [SETUP], and press the soft key [User Corr] to access the <User Corr> page.

User Corr										Home
Open	ON	Load Type			Ls~Rs					Setup
Short	ON	Cable			0m					Meas Setup
Load	OFF									Limit Setup
Pt	Freq (Hz)	Ref		Open		Short		Load		List Setup
		Ls(H)	Rs(Ω)	G(S)	Cp(F)	R(Ω)	Ls(H)	Ls(H)	Rs(Ω)	
1	1.0000k	0.00000μ	20.000m	0.04853μ	22.9121p	2.09409M	-991.362	0.00000μ	0.000m	Trace Setup
2	10.000k	0.00000μ	0.000m	0.00000μ	0.00000p	20.228m	0.04900μ	0.00000μ	0.000m	User Corr
3	100.000k	0.00000μ	0.000m	0.00000μ	0.00000p	21.588m	0.03198μ	0.00000μ	0.000m	Handler
4	100.000	0.00000μ	0.000m	0.00000μ	0.00000p	42.4278M	--.---k	0.00000μ	0.000m	
5	OFF	-----	-----	-----	-----	-----	-----	-----	-----	
6	OFF	-----	-----	-----	-----	-----	-----	-----	-----	
7	OFF	-----	-----	-----	-----	-----	-----	-----	-----	
8	OFF	-----	-----	-----	-----	-----	-----	-----	-----	
9	OFF	-----	-----	-----	-----	-----	-----	-----	-----	
10	OFF	-----	-----	-----	-----	-----	-----	-----	-----	

Figure 3-20 User Correction

The open-circuit, short-circuit and load correction functions on the <User Corr> page can be used to eliminate distributed capacitance, parasitic impedance and other measurement errors.

**Parameter Type:** select from list

- **Full Frequency Correction:** Use insertion method to execute open-circuit and short-circuit correction of all frequency points.
- **Point Frequency Correction:** Execute open-circuit, short-circuit and load correction of the current set frequency point.

The following measurement control parameter setting domains can be set on the <User Corr> page:

- Open-Circuit Correction (Open)
- Short-Circuit Correction (Short)
- Load Correction (Load)
- Cable Length Selection (Cable)
- Load Type
- Point Frequency Correction Switch
- Reference Value; etc.

### 3.8.1 Open-Circuit Correction

The open-circuit correction function can eliminate the error caused by the stray admittance (G, B) connected in parallel with the component under test, as shown in the figure below:

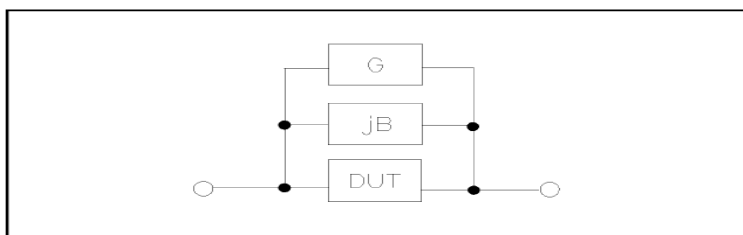

Figure 3-21 Stray Admittance

The following two open-circuit correction data are used:

Regardless of the frequency you currently set, perform an open-circuit correction test on all the following fixed frequency points. In addition, based on the open-circuit correction data at the following frequency points, the instrument can calculate all open-circuit correction data of different measurement ranges which corresponds to all test frequencies by using the interpolation calculation method. Move the cursor to the Open field, and use the soft key [Meas Open] to execute the full frequency open-circuit correction. The fixed frequency points are as follows (some models will be limited due to different frequency ranges).

20 Hz	25 Hz	30 Hz	40 Hz	50 Hz
60 Hz	80 Hz	100 Hz	120 Hz	150 Hz
200 Hz	250 Hz	300 Hz	400 Hz	500 Hz
600 Hz	800 Hz	1 kHz	1.2 kHz	1.5 kHz
2 kHz	2.5 kHz	3 kHz	4 kHz	5 kHz
6 kHz	8 kHz	10 kHz	12 kHz	15 kHz
20 kHz	25 kHz	30 kHz	40 kHz	50 kHz
60 kHz	80 kHz	100 kHz	120 kHz	150 kHz
200 kHz	250 kHz	300 kHz	400 kHz	500 kHz
600 kHz	800 kHz	1 MHz	1.1 MHz	1.2 MHz
1.3 MHz	1.4 MHz	1.5 MHz	1.6 MHz	1.7 MHz
1.8 MHz	1.9 MHz	2 MHz		

#### Operation Steps to Use the Open-Circuit Correction Function:

Open-circuit correction includes full frequency open-circuit correction using interpolation calculation method, and single frequency open-circuit correction for the set frequency point. Carry out the following steps to perform open-circuit correction for full frequency using the interpolation calculation method. For details about single-frequency open-circuit correction, please refer to the "Load Correction" operating instructions.

Move the cursor to the Open setting field, and the following soft keys are displayed in the soft key area of the screen.

- **OFF:** Turn off the open-circuit correction function. The calculation of open-circuit correction will no longer be carried out in the subsequent measurement process.
- **ON:** Turn on the open-circuit correction function, and the correction calculation will be performed in the subsequent test process. If the frequency settings are all OFF, the open-circuit correction calculation uses the correction data of the current frequency calculated by the interpolation method. If the frequency is set to ON, and the current measurement frequency is equal to the corresponding frequency, the correction data of the corresponding frequency will be used for the calculation of the open-circuit correction.

- **Meas Open:** The open admittance (capacitance and inductance) at the above fixed frequency point will be measured. The open-circuit full-frequency correction takes about 75 s.
- **DCR Open:** The open-circuit resistance measurement under the DC resistance function will be performed.

**Note:** Connect the test fixture to the test terminal of the instrument. The fixture is open and not connected to any component under test.

### 3.8.2 Short-Circuit Correction

The short-circuit correction function of ST2840 series instruments can eliminate errors caused by spurious inductance (R, X) in serial with DUT, as shown in the following figure:

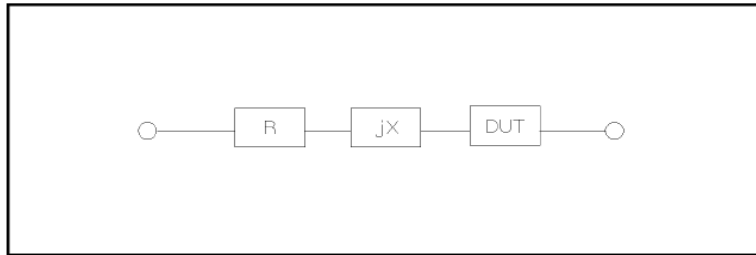

Figure 3-22 Spurious Inductance

The following two short-circuit correction data is used:

Regardless of the frequency you currently set, perform a short-circuit correction test on all the following fixed frequency points. In addition, based on the short-circuit correction data at the following frequency points, the instrument can calculate all short-circuit correction data of different measurement ranges which corresponds to all test frequencies by using the interpolation calculation method. Move the cursor to the Short field, and use the soft key [Meas Short] to execute the full frequency short-circuit correction. The fixed frequency point is the same as the open-circuit correction.

#### Operation Steps to Use the Short-Circuit Correction Function:

The short-circuit correction includes the full-frequency short-circuit correction using the insertion calculation method and the single-frequency short-circuit correction for the set frequency point. Perform the following steps to perform short-circuit correction at full frequency using the insertion calculation method. For details on single-frequency short-circuit correction, please refer to the "Load Correction" operating instructions.

Move the cursor to the short-circuit setting field, and the following soft keys are displayed in the soft key area of the screen.

- **OFF:** Turn off the short-circuit correction function. The calculation of short-circuit correction will no longer be carried out in the subsequent measurement process.
- **ON:** Turn on the short-circuit correction function, and the correction calculation will be performed in the subsequent test process. If the frequency settings are all OFF, the short-circuit correction calculation uses the correction data of the current frequency calculated by the interpolation method. If the frequency is set to ON, and the current measurement frequency is equal to the corresponding frequency, the correction data of the corresponding frequency will be used for the calculation of the short-circuit correction.
- **Meas Short:** Connect the test fixture to the test terminal of the instrument. Short-circuit the test fixture with a short-circuit strip. Press the soft key [Meas Short], and the parasitic impedance (resistance and reactance) at the above fixed frequency point will be measured. The short-circuit full-frequency correction takes about 75 s.
- **DCR Short:** The short-circuit resistance measurement under the DC resistance function will be performed.



### 3.8.3 Load Correction

The load correction function uses the transfer coefficient between the actual test value at the set frequency point and the standard reference value to eliminate other test errors. It can be seen that open circuit, short circuit and load correction can be performed at the set frequency point. Before setting the standard reference value, the reference value must be set in the reference value corresponding field. When the cursor moves to Freq or Ref, the screen displays the soft key [Load]. Press the [Load] key to perform a load correction test on the standard.

**Parameter Type:** ON/OFF

- **OFF:** Deactivate the load calibration test data under the current set frequency.
- **ON:** Activate the load calibration test data under the current set frequency.

#### 3.8.3.1 Load Type

When performing load correction, the reference value of the standard device must be input in advance.

The test parameters of the reference value should be consistent with the set load correction measurement function. The load correction function uses the transfer coefficient between the actual test value at the set frequency point and the standard reference value to eliminate other test errors. The load correction measurement function is only used to calculate the transfer coefficient.

This series categorizes the load types into 3 categories:

- $L_s \sim R_s$
- $L_s \sim Q$
- $C_p \sim D$

### 3.8.4 Cable

The cable length currently available is 0 m and 1 m. The factory default is 0 m.

### 3.8.5 Point Frequency Operation

Follow the steps below to perform an open/short/load correction test on the set frequency point. Move the cursor to the frequency setting area. The screen will display the following soft keys:

- **OFF:** Deactivate the open-circuit/short-circuit/load correction data at the currently set frequency.
- **ON:** Activate open-circuit/short-circuit/load correction data at the currently set frequency; the frequency setting field then displays the originally set open-circuit/short-circuit/load correction frequency.
- **Open:** Perform an open-circuit correction at the current frequency.
- **Short:** Perform a short-circuit correction at the current frequency.
- **Load:** Perform a load correction at the current frequency.

**Operation Steps to Use the Load Correction:**

- 1) Move the cursor to the FREQ setting area, and set the frequency to be calibrated.
- 2) Open the test fixture, and press the soft key [Open] to perform open-circuit correction for the current set frequency.
- 3) Short-circuit the test fixture and press the soft key [Short] to perform short-circuit correction for the current set frequency.
- 4) Prepare a measurement standard device, move the cursor to the Load Type setting field, and set the type of function parameters that the standard device needs to measure.

- 5) Move the cursor to the corresponding frequency setting domain, connect the standard device to the test fixture, press the soft key [Load], and the instrument will perform a load calibration. The actual measurement result of the standard device is displayed on the load.

## 3.9 Handler Settings











LCR Handler								Function
Handler	User define							
Pin	Signal	Direction	Function	Pin	Signal	Direction	Function	
1	BIN1	Output		14,15	ExtDCV2	Input	3.3V ~ 24V	OFF
2	BIN2	Output		16,17,18	+5V	Output	I <sub>max</sub> < 0.3A	OFF
3	BIN3	Output		19	Pass	Output		
4	BIN4	Output		20	Fail	Output		
5	BIN5	Output		25	Lock	Input		
6	BIN6	Output		27,28	ExtDCV1	Input	3.3V ~ 24V	
7	BIN7	Output		29	Alarm	Output		
8	BIN8	Output		30	Index	Output		
9	BIN9	Output		31	Eom	Output		
10	BIN10	Output		34,35,36	Com1	Input	GND1	
12,13	ExtTrig	Input		32,33	Com2	Input	GND2	
11,21,22 23,24,26	Reserve							

Figure 3-23 Handler Settings

The input and output I/O interfaces are active low by default, and the trigger mode can be changed as needed. For details on the handler interface, refer to Chapter 10 Handler Interface Description.

## 4 System and File

### 4.1 <System Setup>

Press the menu key [SYSTEM] to enter the <System Setup> page.

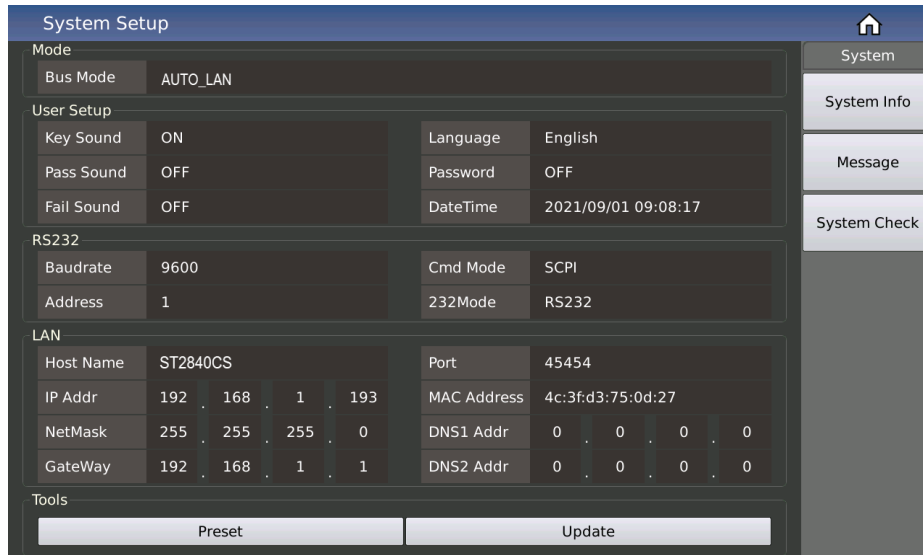

Figure 4-1 System Setup

This function page displays most of the system setup menus, including the meter function, beeper on, pass beep, fail beep, system language, password setting, bus mode, GPIB address, talk only, baud rate, time, etc.

#### 4.1.1 Mode Setup

**Bus Mode:** The bus mode is used to select the communication mode of the instrument.

Setting Option	Description
AUTO	Automatically select the RS232/LAN/USB communication mode according to the external signal input
RS232	RS232
	External 485
	External GPIB
LAN	–
USB Device	USBCDC
	USBTMC

**Note:** The Sourcetric GPIB option must be installed to support the GPIB mode.

When using the RS485 or GPIB interface, the bus address under the RS232 setting will be used as the local address.

## 4.1.2 User Setup

### 4.1.2.1 Key Sound

**Parameter Type:** ON/OFF

### 4.1.2.2 Pass Sound

This parameter is used to control and display the sound mode when the measurement comparison result of the instrument is qualified.

**Parameter Type:** select from list

- OFF
- Two Short
- Low Long
- High Short
- High Long

### 4.1.2.3 Fail Sound

This parameter is used to control and display the alarm sound mode when the measurement comparison result of the instrument is defective.

**Parameter Type:** select from list

- OFF
- Two Short
- Low Long
- High Short
- High Long

### 4.1.2.4 System Language

This parameter is used to control and display the operating language currently set on the instrument.

**Parameter Type:** select from list

- English
- Chinese

### 4.1.2.5 Password

This parameter shows the current password protection mode.

**Parameter Type:** select from list type + input type

- **OFF:** Turn off password protection
- **Lock System:** Activate password protection, including file protection
- **Lock File:** File protection for users
- **Lock Setup:** used to restrict modifications on the settings file

- **Modify:** This soft key is used to change the password. After pressing this button, enter the new password according to the prompt on the screen. After inputting from the keyboard, the screen prompts to confirm the new password, repeat the new password, and the password modification is completed.

**Note:** The factory default password is **2840**.

#### 4.1.2.6 Date/Time

Here you can modify the system time and date.

### 4.1.3 RS232 Settings

The general setting parameters of the serial port are: 8 data bits, 1 stop bit, no parity bit.

#### 4.1.3.1 Baud Rate

This parameter is used to select the baud rate of the built-in RS232 interface of the instrument.

**Parameter Type:** select from list

- 4800
- 9600
- 19200
- 38400
- 57600
- 115200

#### 4.1.3.2 Bus Address

**Parameter Type:** numeric input

This parameter is used to control and display the RS485, GPIB interface and Modbus address.

**Value Range:** 1 ~ 32

#### 4.1.3.3 Command Mode

This parameter is used to set the command mode with SCPI command and modbus command protocol.

**Parameter Type:** select from list

- **SCPI:** Adopt general ASCII string command protocol
- **Modbus:** Adopt modbus command protocol

For a more detailed introduction, please refer to Chapter 9 Command Reference.

## 4.1.4 LAN

Configure the corresponding address parameters according to the specific attributes of the connected LAN, and plug in the network cable on the rear panel to use the network port for communication.

If you need to modify the relevant address parameters, you can directly double-click the corresponding address display window to pop up the numeric keyboard, enter the correct network configuration on the numeric keyboard, and click OK to exit the keyboard to complete the modification;

If the connected networking equipment (router or switch) supports the automatic IP allocation function, you can directly click the automatic configuration button in the display window to try the automatic configuration. The configuration takes a few seconds. Do not operate the machine during the configuration process. If the equipment does not support it, you need to manually assign the setting address.

If the automatic configuration fails, you may get the loopback IP address of the machine, that is, 127.0.0.1; at this time, you can click the default setting button in the display window to restore the default configuration, and then start again on the basis of the default configuration. Just make fine adjustments, and you can consult the company's network technical engineer to obtain the address parameters of the network configuration.

**Default Port Number:** 45454

The host name generally corresponds to the instrument model.

## 4.1.5 Tools

### 4.1.5.1 Preset

For the convenience of customers, the instrument can be initialized to a known unified initial state.

Standardize initial software operation design in order to solve the problem of inconsistent setting status when the instrument leaves the factory.

Nr.	Option	Description	Command
1	CLEAR SETTING	Restore the following parameters to the factory default settings: a. Parameters set through front panel operation b. Parameters set by SCPI commands	*RST
2	CLEAR SET & CORR	Restore the following parameters to the factory default settings: a. Parameters set through front panel operation b. Parameters set by SCPI commands c. Power-off protection parameters d. Clear user correction data	:SYST:PRES
3	FACTORY DEFAULT	Restore the following parameters to the factory default settings: a. Parameters set through front panel operation b. Parameters set by SCPI commands c. Power-down protection data d. Clear user reset data e. Clear files saved by users	:SYS:DEFT

**Note:** Parameters that cannot be initialized:

- The initialization operation is not allowed to clear the system calibration data.
- The real-time clock date and time are not allowed to be cleared or initialized.

### 4.1.5.2 Software Update

This function is used for software version updates and maintenance. ST2840 series instruments are designed with multiple CPUs. For your convenience, a one-key option to update firmware is provided. After the one-key update, you need to wait only about 15 seconds (refer to the prompts on the screen). After the update is completed, the instrument will automatically restart. After restarting, you can return to this menu to check that the software version you are now using is the latest version.

The instrument provides several options for software updates, including performing the update directly on the specified file in the file system management list, or using the default upgrade path (that is, performing the upgrade by running the "usb-update2840.sec" file).

To do so, simply place the "update2840.sec" file in the root directory of the USB flash drive; the device will now perform the update. This can also be used in conjunction with our own PC tool to update the specified file on the PC.

The menu is shown in Figure 4-2:

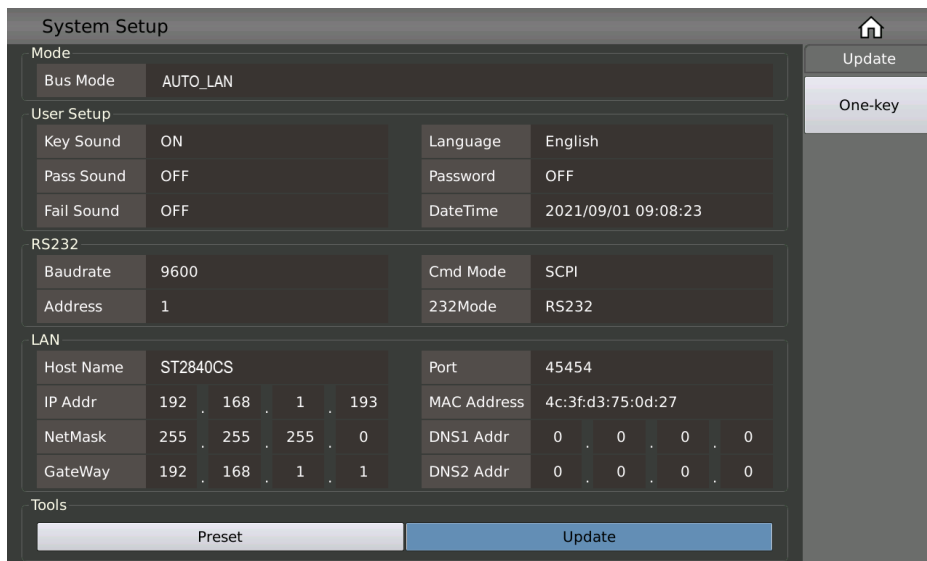

Figure 4-2 Update Menu

The dynamic prompt window of the one-click upgrade is shown in Figure 4-3:

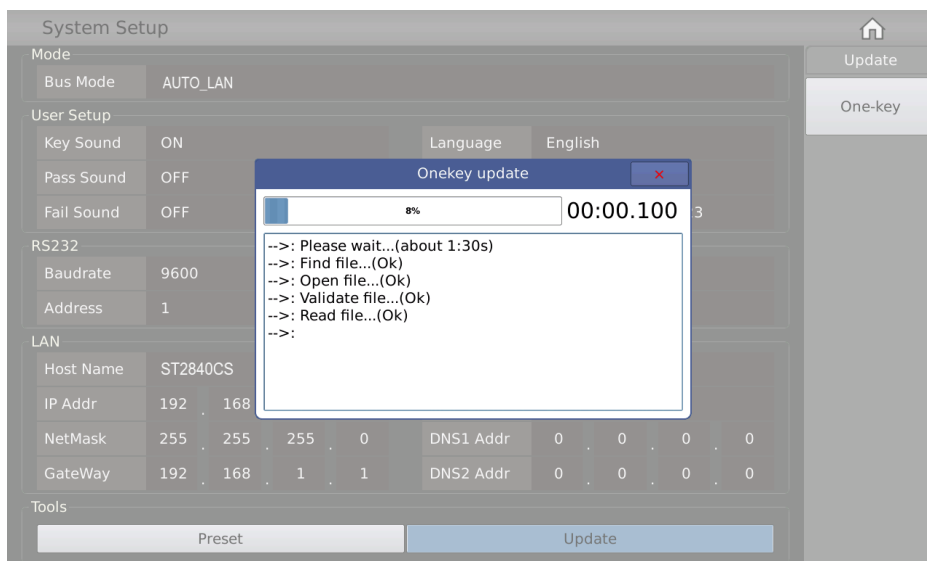

Figure 4-3 Update Pending Prompt

## 4.2 <File>

As your instrument is equipped with an embedded file system, it can be very convenient to store the custom-set parameters as a file, either in the system's internal drive or on an external USB drive. This way you won't have to re-configure the parameters next time if you want to use the same settings again; you can simply load the corresponding file, saving you time and improving efficiency.

Press the soft key [FILE] to enter the <File> function page.

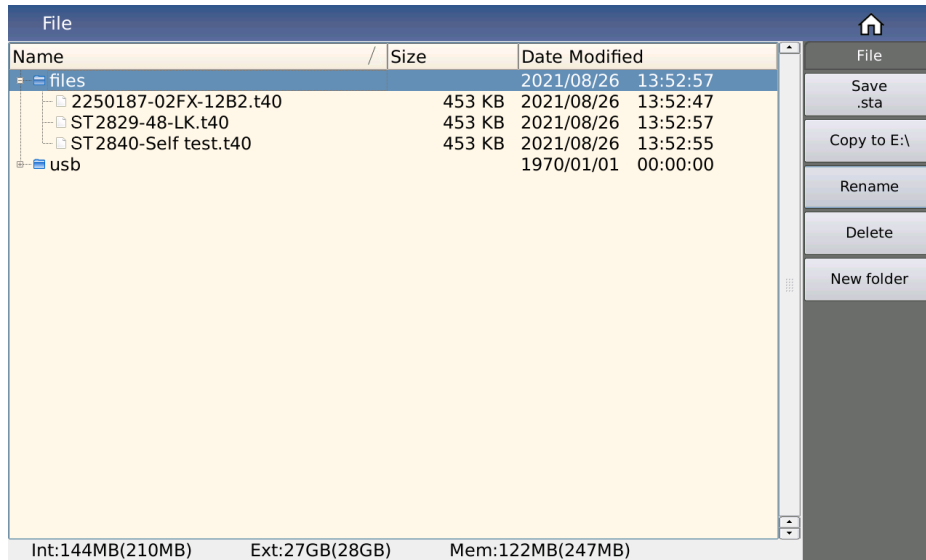

Figure 4-4 File Function Page

### 4.2.1 USB Drive Performance Management

As mentioned above, this series comes equipped with a USB host interface. An external USB flash drive can be used as a storage medium, thus breaking the limitation of the internal storage size of the instrument. You can also copy these files to an IBM PC with a USB interface or a desktop computer or Notebook computers compatible with it, so as to achieve unlimited expansion.

Supports USB storage devices (USB flash drives) that fulfil the following criteria:

- Compliant with USB 2.0 standard
- File format: FAT16 or FAT32 (formatted with Microsoft Windows operating system)

### 4.2.2 Introduction to the Save/Load Function

Using the save/load function, you can save configuration information either to the device's own internal drive or to an external USB flash drive, and in turn load files from there.

#### Setting Options:

- **files:** internal file
- **usb:** external file



The following table explains the available storage methods and their uses:

Storage Method		Loadable	Usage
Type	File Format		
LCR Settings	*.sta	Yes	Save the LCR measurement configuration status.
Transformer Single-Group Settings	*.trt	Yes	Save the transformer single-group measurement configuration status.
Transformer Sweep Settings	*.t40	Yes	Save the transformer sweep measurement configuration status.
Screenshot	*.png	No	Save a screenshot of the display.
Measurement Data	*.csv	No	Save measurement data

**Note:** Measurement results and screenshots can only be saved to the external USB flash drive.

### 4.2.3 Basic Menu Operations of File Management

The up and down keys and the knob of the arrow keys are used to move the file cursor up and down, and the left and right keys of the arrow keys are used to operate the expanded state of the current path;

Click to select the file name to be operated, and the operation can be performed as follows according to the toolbar on the right side of the screen:

- **Save .sta/.trt/.t40:** Depending on the current measurement, this refers to the LCR mode, the transformer single group mode, and the transformer sweep mode. The default menu is the corresponding file save menu. When the cursor is on the files path, the measurement will be carried out after inputting the file name. The settings file is saved in the root directory.
- **Copy to E:\:** When the cursor is on an internally stored file or folder, this will copy it to the USB root directory.
 

**Note:** If you are copying a single file, it will overwrite any file of the same name in the USB path; if you are copying a folder, please make sure that there is no folder with the same name in the USB root directory, otherwise it will cause the error message "Copy Failed".
- **Copy to I:\:** When the cursor is on a file or folder stored on the USB device, this will copy it to the internal root directory.
- **Delete:** Delete the file or folder at the cursor's position.
- **Load:** Load the settings file specified by the file index to re-configure the parameter settings of the instrument.
- **Rename:** Rename the file or folder at the cursor's position.
 

**Note:** The root directory provided is not modifiable.
- **New Folder:** Create a new folder directory at the current cursor location; you can save a new test file in the newly created folder directory.

## 4.2.4 Operation Steps for File Management (Save/Load)

Move the cursor using the up and down arrow keys and the knob; expand and zoom in and out using the left and right arrow keys of the arrow keys.

### 4.2.4.1 Save File

Move the cursor to the folder or any file in the folder where you want to save the settings file, and the corresponding menu area will display the file menu:

- Load (if it is a loadable file type)
- Save
- Copy to E:\
- Rename
- Delete
- New folder

Press the [Save] soft key, the screen will display a numeric keyboard to input the file name. The file name suffix is automatically generated, so only the first part of the file name needs to be input manually. After the input is confirmed, your file should show up in the directory.

### 4.2.4.2 Load File

When you move the cursor to a loadable file in the file list or directly enter the file number of a loadable file, this option will be displayed.

Press the [Load] soft key, and the following confirmation dialog box will be displayed on the screen:

- **Load:** The currently selected file is loaded. After loading, the instrument will automatically return to the corresponding measurement display page.
- **Cancel:** Cancel the current loading operation and return to the previous screen.

### 4.2.4.3 Copy File

When you move the cursor to the folder or file to be copied, the menu area will display:

- **Copy to E:\:** Copy the file to the root directory of the external storage USB disk.
- **Copy to I:\:** Copy the file to the internal root directory of the instrument.

**Note:** Please make sure that your USB flash drive meets the standards described in this section and is not set to read-only mode (write-protected).

## 5 Execute LCR Measurement and Some Examples

### 5.1 Corrections

You can select one of two correction modes (applied to the entire list via sweep mode or applied to one specific frequency point) to execute an open-circuit or short-circuit correction; this will help prevent the stray impedance from affecting test accuracy.

#### 5.1.1 Sweep Correction

- 1) Press the menu key [CAL] and the instrument will display the <Correction> page.
- 2) Move the cursor to the Open zone. ON, OFF, [Meas Open] and [DCR Open] will be displayed in the soft key zone.
- 3) Keep the test fixture be in the open status, then press [Meas Open] to execute an open-circuit correction until the prompt information zone displays that open-circuit correction is finished.
- 4) Press ON to turn on the open-circuit correction function.
- 5) Insert the short plate (ST26010) to the test fixture.
- 6) Move the cursor to the Short zone. ON, OFF, [Meas Short] and [DCR Short] will be displayed in the soft key zone.
- 7) Press [Meas Short] to execute the short-circuit correction till the prompt information zone displays that the short-circuit correction is finished.
- 8) Press ON to turn the short-circuit correction function.
- 9) Move the cursor to the Load zone. ON, OFF will be displayed in the soft key zone.
- 10) Press OFF to turn off the load correction function.
- 11) Move the cursor to the Freq zone, ON, OFF, [Meas Open], [Meas Short] and [Meas Load] will be displayed in the soft key zone.
- 12) Press OFF to turn off the point-frequency correction function of Freq.

#### 5.1.2 Point-Frequency Correction

This function will yield better results in a single-frequency test.

If the measurement frequency is 5.5 kHz...

- 1) Press the menu key [CAL] and the instrument will display the <Correction> page.
- 2) Move the cursor to the Freq zone, ON, OFF, [Meas Open], [Meas Short] and [Meas Load] will be displayed in the soft key zone.
- 3) Press ON to turn on the point-frequency correction function of Freq.
- 4) Press the key to input the specified frequency size of 5.5k. The frequency area will be changed to 5.5000 kHz (the same as the measurement frequency).
- 5) Keep the test fixture open and press [Meas Open] to execute an open-circuit correction.
- 6) Insert the short plate (ST26010) to the test fixture.
- 7) Press [Meas Short] to execute a short-circuit correction.

## 5.2 Correct Connection of DUT

The instrument has Hcur (current sampling high end Hc), Lcur (current sampling low end Lc), Hpot (voltage sampling high end Hp), Lpot (voltage sampling low end Lp) and a total of four pairs of test terminals corresponding to the shielding end of each test terminal.

Each terminal contains a shielding layer whose function is to reduce the influence of the ground stray capacitance and the interference of the electromagnetic field.

In the process of measuring, Hcur, Hpot and Lpot, Lcur should be connected with DUT lead to form a complete 4-terminal measurement, thus reducing the effect of the lead and the connection points on the measurement results (especially the dissipation measurement). When measuring low-ohm components, Hpot, Lpot should be connected to the lead terminal so as to avoid the impedance being added to the lead impedance; the connection principle is that the Hpot and Lpot test should be the actual existed voltage on DUT.

**Note:** In other words, before connecting to DUT, it is not recommended to connect Hcur, Hpot with Lpot, Lcur, as doing so will increase test error!

If the connection point and the lead resistance  $R_{lead}$  are far weaker than the tested impedance (for example:  $R_{lead} < Z_x / 1000$ , the accuracy error is required to be less than 0.1 %), before connecting to DUT, it is recommended to connect Hcur, Hpot and Lpot, Lcur (two terminal test).

In a test with a high accuracy requirement, using a Kelvin test fixture (standard accessory) will gain better results than using test leads. When a Kelvin test lead is used under 10 kHz, a better measurement result can be obtained. However, when the frequency is higher than 10 kHz, it cannot meet the measurement demand. At a high frequency, the change of the clearance between test leads will directly change stray capacitance and inductance on test terminals – this problem is unavoidable because the test leads cannot be fixed in a position.

So, at a high frequency, a test fixture should be used if possible. If there is no test fixture available or none can be used, the status of test leads should be the same in the processes of correction and test.

No matter the standard Kelvin test fixture or Kelvin test leads or user-made fixture is used, the following requirements should be met:

Distribution impedance must be reduced to a minimum especially when measuring high impedance components.

Contact resistance must be reduced to a minimum.

Short-circuit and open-circuit must be available between contact points. Open-circuit and short-circuit correction can easily reduce the influence of distribution impedance of the test fixture on measurement. For open-circuit correction, the clearance between test terminals should be the same as that when they connect with DUT. For short-circuit correction, the short plate of low impedance should be connected between test terminals. Another way is to directly connect Hc with Lc or Hp with Lp, then connect both.

**Note:** When the DUT is a polarity component, before measuring, the high potential terminal should be connected to the terminal with mark "+", "Hc" or "Hp" and the low terminal should be connected to the terminal with mark "-", "Lc" or "Lp".

<b>Warning!</b>	
	Before measuring, please discharge the tested polarity component so as to avoid the damage to the instrument.

### 5.3 Eliminate the Influence of Stray Impedance

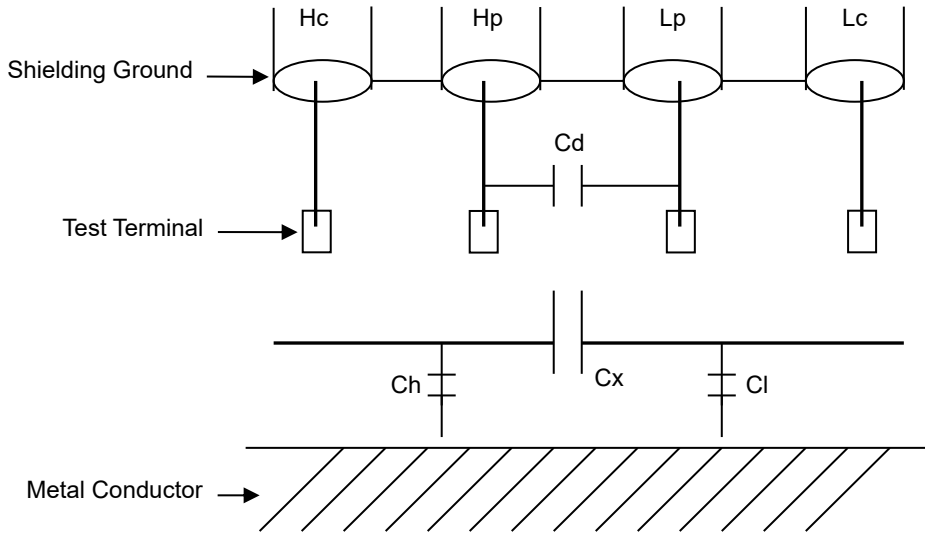

Figure 5-1 Influence of Stray Impedance (Problem)

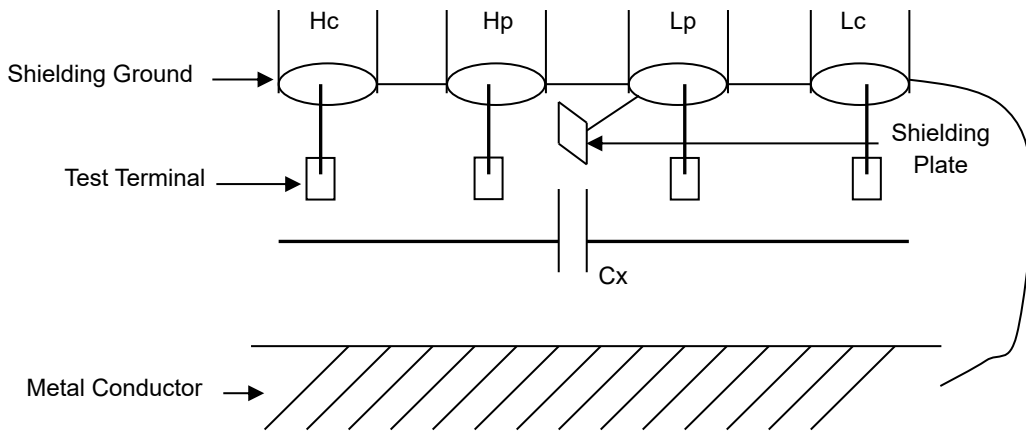

Figure 5-2 Influence of Stray Impedance (Solution)

When the DUT has high impedance (such as small capacitance), the influence of stray capacitance cannot be ignored. Figure 5-1 is an example of the use of 4 terminal pair measurement. In this figure, Cd is connected with Cx in a parallel way and when a conductance plate is positioned under DUT, capacitance Ch will connect with Cx in parallel after connecting with Cl in series; this way the measurement result will have errors. If a ground conductor is installed between high and low terminals, Cd can be reduced to minimum. Meanwhile if the ground terminal is connected to the conductance plate, the influence of Ch and Cl will be eliminated.

When the DUT is low impedance (such as small inductance, large capacitance), a large current will flow through the test leads Hc and Lc. In this case, **electromagnetic coupling between test leads becomes the main source of test errors**, except for the influence of the contact resistance on test terminals. If this coupling cannot be eliminated, it will bring unexpected influence on measurement results.

Generally, contact resistance affects the resistance of impedance and electromagnetic affects the reactance of impedance. Test terminals can adopt a 4-terminal-pair (4TP) connection method.

With a 4TP connection, the currents flow though Hc and Lc are equal in value and opposite in direction compared to those flowing through each shielding terminals (the current reflow from Hc to shielding layer). This way, the magnetic fields produced by these currents can be mutually offset and further eliminate the influence of mutual inductance coupling on measurement results.

## 5.4 Example: Testing Inductance

### 5.4.1 Measurement Settings

**Function:** Ls-Q

**Frequency:** 5.5 kHz

**Level:** 1.5 V<sub>rms</sub>

**Internal impedance:** 100 Ω

### 5.4.2 Operation Steps

- 1) Turn on the instrument.
- 2) Set basic parameters.
- 3) Press [DISP] to enter into the <Meas Display> page.
- 4) Move the cursor to the Parameter area, the optional parameters are in the soft key area on the right side of the screen.
- 5) Press Ls to select Ls measurement function.
- 6) Move the cursor to Freq, the current frequency is 1.0000 kHz. The frequency can be modified as needed.
- 7) Move the cursor to Level, the current displayed level will be 1.000 V.
- 8) Press [SETUP] to enter into the <Meas Setup> page.
- 9) Move the cursor to R<sub>SOU</sub> zone, 100 Ω and 30 Ω will be displayed in the soft key zone.
- 10) Press 100 Ω to select 100 Ω as the signal internal impedance.
- 11) Connect the test fixture (ST26005) to the test terminals.
- 12) Perform a correction (to avoid the influence of stray impedance on measurement accuracy, an open-circuit/short-circuit correction is needed)
- 13) Mount the tested inductance to the test fixture.
- 14) Execute test operation.
- 15) Press [DISP] to enter into the <Meas Display> page. The instrument will continuously test and put the measurement result in the center of the page.

Meas Display											⏏	
Frequency	100.000kHz	Speed	Fast+	DC Bias	0.000 V						Display	
AC Level	1.000 V	AC Range	Auto	Vm	OFF						Meas Display	
DC Level	1.000 V	DC Range	Auto	Im	OFF						List Display	
Cp	-7.09283 μF			Dev	OFF						Trace Display	
Xs	186.705 mΩ			Ref	0.00000 F						Save	
Z	OFF			BIN1_H	----						OFF	
θz°	OFF			BIN1_L	----							
LAST	BIN1	BIN2	BIN3	BIN4	BIN5	BIN6	BIN7	BIN8	BIN9	BIN10	FAIL	
----	0	0	0	0	0	0	0	0	0	0	0	

- 16) If the measurement result is obviously incorrect, please check the following items.
- Check the tested inductance is in good connection with the test fixture or not.
  - Check the test fixture is in good connection with the test terminals of the instrument or not.
  - Redo the open-circuit/short-circuit correction.

**Note:** When the sweep open-circuit/short-circuit correction is used, the point-frequency correction should be set to OFF.

## 5.5 Example: Testing Capacitance by Multi-Frequency List Sweep

### 5.5.1 Measurement Settings

**Function:** Cp, D

**Level:** 1 V<sub>rms</sub>

**Other Parameters:**

Frequency	Comparison Parameter	Low Limit	High Limit
1 kHz	Cp (capacitance)	325.0 nF	333.0 nF
10 kHz	D (dissipation)	0.0001	0.0003
100 kHz	D (dissipation)	0.0060	0.0100

**Sound:** High Long

**Alarm Mode:** OFF

### 5.5.2 Operation Steps

Turn on the instrument.

**Configure Basic Parameters:**

- Press [DISP] to enter into the <Meas Display> page.
- The Parameter zone is currently displayed as Cp, D and the Level zone is 1.000 V.
- Press [SETUP] to enter into the <Meas Setup> page, meanwhile the following soft keys will be displayed in the soft key zone: [Meas Setup], [User Corr], [Limit Setup], [List Setup] and [FILE].
- Press the [List Setup] button to enter into the <List Setup> page.
- Press the knob to move the cursor to the parameter area of sweep point 1, modify the measurement conditions of the current point, including Frequency, Level, Bias, Limit, Delay, etc.

**Sound Setup:**

- Press [SYSTEM] to enter into the <System Setup> page.
- Move the cursor to the Fail Sound zone to select [High Long].
- Mount the test fixture (ST26005) to the test terminals of the tester.
- Execute correction function (to avoid the influence of the stray impedance on the measurement accuracy, an open-circuit/short-circuit correction is needed).
- Insert the tested capacitor to the test fixture.

**Execute Test Operations:**

Press [DISP] and then [List Sweep] to enter into the <List Sweep Display> page. The instrument will test continuously and then display the test and the comparison results on page. If the comparison result is PASS or FAIL, there is a sound alarm.

List Display									Display
Pt	Freq	Level	Bias	Para1	Para2	Para3	Para4	P/F	
1	1.00000kHz	1.00000 V	0.00000 A	Cp=-22.9015pF	Cp=-22.9015pF	Cp=-22.9015pF	Cp=-22.9015pF	---	Meas Display List Display Trace Display Save OFF
2	1.00000kHz	1.00000 V	0.00000 A	Cp=-22.9015pF	Cp=-22.9015pF	Cp=-22.9015pF	Cp=-22.9015pF	---	
3	1.00000kHz	1.00000 V	0.00000 A	Cp=-22.9015pF	Cp=-22.9015pF	Cp=-22.9015pF	Cp=-22.9015pF	---	
4	1.00000kHz	1.00000 V	0.00000 A	Cp=-22.9015pF	Cp=-22.9015pF	Cp=-22.9015pF	Cp=-22.9015pF	---	
5	1.00000kHz	1.00000 V	0.00000 A	Cp=-22.9015pF	Cp=-22.9015pF	Cp=-22.9015pF	Cp=-22.9015pF	---	
6	1.00000kHz	1.00000 V	0.00000 A	Cp=-22.9015pF	Cp=-22.9015pF	Cp=-22.9015pF	Cp=-22.9015pF	---	
7	1.00000kHz	1.00000 V	0.00000 A	Cp=-22.9015pF	Cp=-22.9015pF	Cp=-22.9015pF	Cp=-22.9015pF	---	
*8	1.00000kHz	1.00000 V	0.00000 A	Cp=-22.9015pF	Cp=-22.9015pF	Cp=-22.9015pF	Cp=-22.9015pF	---	

If the measurement result is obviously incorrect, please check the following items:

- Check the tested inductance is in good connection with the test fixture or not.
- Check the test fixture is in good connection with the test terminals of the instrument or not.
- Redo the open-circuit/short-circuit correction.

**Note:** When the sweep open-circuit/short-circuit correction is used, the point-frequency correction should be set to OFF.

## 5.6 Example: Load Correction

### 5.6.1 Measurement Settings

Assume the following measurement conditions:

**Frequency:** 100 kHz

**Cp Standard Value:** 11 nF

**D Standard Value:** 0.0005

### 5.6.2 Operation Steps

- Press [CAL], the instrument will display the <User Corr> page.
- Move the cursor to Load, the following soft keys will be displayed in the soft key zone: ON and OFF.
- Press ON to turn on the load correction function.
- Move the cursor to Load Type, [Ls-Rs], [Ls-Q], [Cp-D] will be displayed in the soft key area on the right side of the screen.
- Press [Cp-D] to select the Cp-D function.
- Move the cursor to Freq zone, the following soft keys will be displayed in the soft key zone: ON, OFF, [Open], [Short] and [Load].



- 7) Press ON to turn on the point-frequency correction function of the corresponding Freq in current correction point.
- 8) Input the correction frequency (100k), reference A (11 nF), reference B (0.0005)
- 9) Move the cursor to Freq zone, the following soft keys will be displayed in the soft key zone: ON, OFF, [Open], [Short] and [Load].
- 10) Hold the test fixture be in open status and keep user's hands or other interference source be far away from the test fixture. Press the soft key [Open] to execute an open-circuit correction.
- 11) Insert the short plate (ST26010) into the test fixture. Please ensure that the short plate and the reeds of the test fixture have good contact.
- 12) Press the soft key [Short] to execute a short-circuit correction.
- 13) Insert a standard capacitance into the test fixture. Please ensure that the pins of the standard capacitance have good connection with the reeds of the test fixture.
- 14) Press the soft key [Load] to execute a load correction.

**Note:** Due to different software versions, the soft keys and status information may be slightly different from the way it is referenced in this manual, but this should not affect your general understanding of the processes.

The load correction is only valid for the components with the same specification. If the specification is changed, the load correction must be redone.

## 6 Transformer Single-Machine Test

### 6.1 Circuit for Transformer Single-Machine Test

#### 6.1.1 Some Transformer Parameters

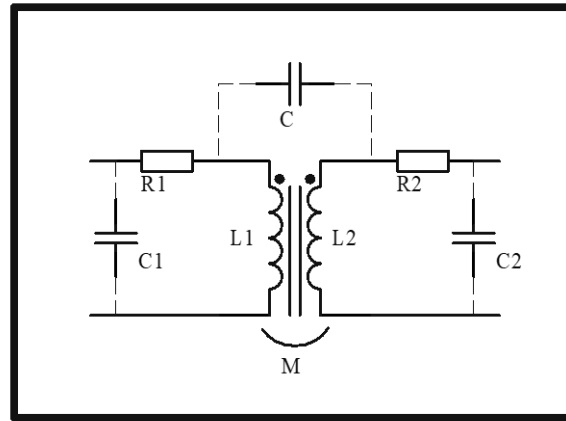

#### 6.1.2 Transformer Single Test Circuit and TURN Test

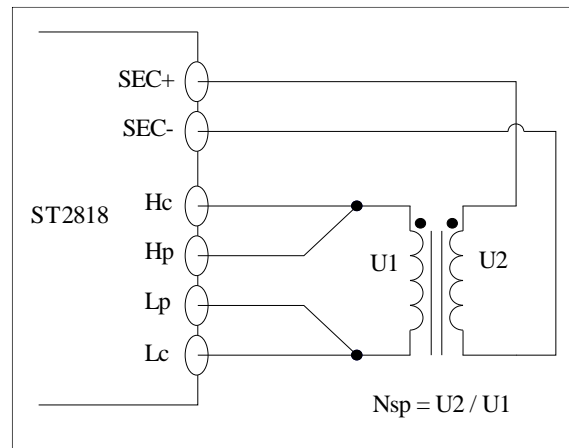

On ST2840X, TURN test has 4 display modes:

$$N_s:N_p = U_2 / U_1$$

$$N_p:N_s = U_1 / U_2$$

$$N_s = N_p \times U_2 / U_1$$

$$N_p = N_s \times U_1 / U_2$$

The above  $U_1$  and  $U_2$  are the values automatically measured by the instrument, and the values of  $N_p$  and  $N_s$  need to be set by the user in advance on the corresponding turns ratio parameters on the <Single Setup> page.

We recommend you put the winding group with more turns in primary winding rate; the reasons are as follows:

- Due to the influence of output internal resistance (30; 100), when the primary inductance is too small, the distributed voltage signal is small and the transformer gets weak energy. As the test cable and relay will attenuate some energy, the stability and the accuracy of test will be affected.

- If the primary signal is enlarged, the secondary winding of the winding with more turns will generate higher voltage which may be beyond the acceptable range thus affecting the test accuracy.
- If the winding group with more turns is put in primary class, then the transformer can get higher energy thus the two problems above can be avoided.

### 6.1.3 Transformer Leakage Inductance Test

When using the circuit discussed in the last section to execute an automatic sweep test on the leakage inductance of primary inductance  $L_1$ , the instrument will automatically use the relay to short the secondary winding of the transformer so as to test the leakage inductance. There is inevitably magnetic leakage from transformer secondary winding to inner relay, so this area will necessarily have some error of leakage inductance.

If you want to obtain an accurate leakage value, please short the secondary winding of the transformer based on the figure below.

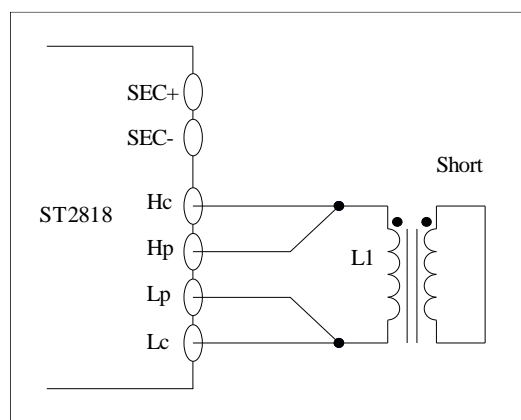

### 6.1.4 Capacitance Test Between Windings of Transformer

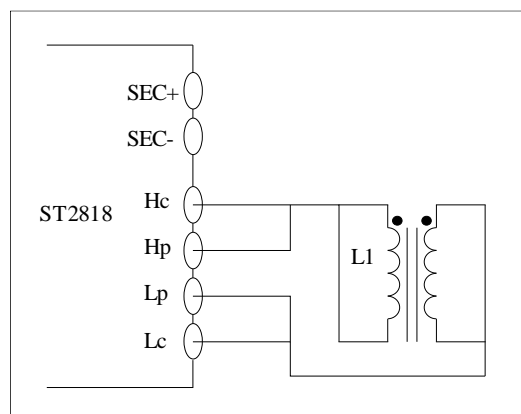

## 6.2 <Transformer Single Setup>

Press the shortcut key [HOME] to enter the function selection interface, as shown in the figure below:

Single Setup											Parameter		
Trigger	Continue		Speed		Fast		Test Mode		Seq		Ls	Lp	Lk
Rsou	100Ω		Bias Source		100mA(40V)		Comp		OFF				
Para	Freq(Hz)	Level(V)	Other	Dev	Nominal	Low	High	Delay	Avg	Meas	Cs	Cp	Zx
Ls	1.0000k	1.000	DCV : 1.000 V	OFF	0.0000 H	-----	-----	0 s	1	OFF	Rs	Rp	Rd
Lp	1.0000k	1.000	DCV : 1.000 V	OFF	0.0000 H	-----	-----	0 s	1	OFF	D	Q	dZ
Lk	1.0000k	1.000		OFF	0.0000 H	-----	-----	0 s	1	OFF	Ns	Ns:Np	
Cs	1.0000k	1.000		OFF	0.0000 F	-----	-----	0 s	1	OFF	Np	Np:Ns	
Cp	1.0000k	1.000		OFF	0.0000 F	-----	-----	0 s	1	OFF	Move Up		
Zx	1.0000k	1.000	DCV : 1.000 V	OFF	0.0000 Ω	-----	-----	0 s	1	OFF	Move Down		
Rs	1.0000k	1.000		OFF	0.0000 Ω	-----	-----	0 s	1	OFF	Help		
Rp	1.0000k	1.000		OFF	0.0000 Ω	-----	-----	0 s	1	OFF			
Rd		1.000		OFF	0.0000 Ω	-----	-----	0 s	1	ON			
D	1.0000k	1.000		OFF	0.0000	-----	-----	0 s	1	OFF			
Q	1.0000k	1.000	DCV : 1.000 V	OFF	0.0000	-----	-----	0 s	1	OFF			
dZ	1.0000k	1.000	DCV : 1.000 V	OFF	0.0000 °	-----	-----	0 s	1	OFF			

Figure 6-1 Single Setup

Move the cursor to the Single Setup area or directly touch the single group setting area to access the <Single Setup> page.

This display function page is used to set transformer measurement parameters; such as:

- Measurement Settings for Turns
- Measurement Settings for Primary Inductance
- Measurement Settings for Primary Leakage Inductance
- Measurement Settings for Primary DC Resistance
- Measurement Voltage
- Frequency
- Offset
- Deviation
- Nominal Value
- Lower Limit
- Upper Limit
- Delay
- Average
- Measurement ON/OFF, etc.

### 6.2.1 Trigger

See the trigger description in the LCR measurement setup chapter.

### 6.2.2 Speed

See the speed description in the LCR measurement setup chapter.

### 6.2.3 Test Mode

Move the cursor to the Test Mode area; the soft key zone will display [Seq] and [Step].

- If you press [Seq], the Test Mode zone will display Seq, which means the instrument is in sequential / continuous trigger mode. Trigger once, the instrument will sweep the transformer parameter circularly.
- If you press [Step], the Test Mode zone will display Step, which means the instrument is in single-step / single trigger mode. Trigger once, the instrument will sweep the transformer parameter one time.

### 6.2.4 R<sub>sou</sub>

Move the cursor to the R<sub>sou</sub> (internal resistance) area; the menu area on the right side of the screen will display [100 Ω] and [30 Ω].

- If you press [100 Ω], the internal resistance area will display 100 Ω, which means the output impedance of the instrument is 100 Ω.
- If you press [30 Ω], the internal resistance area will display 30 Ω, which means the output impedance of the instrument is 30 Ω.

Please refer to the detailed introduction of output impedance.

### 6.2.5 Bias Source

Move the cursor to the bias source area; the menu area on the right side of the screen will display: [100 mA (40 V)], [2 A].

- If you press [100 mA (40 V)], the bias source area will display 100 mA (40 V), which means that the 100 mA(40 V) bias source is selected. The bias source can output a maximum voltage of 40 V when in voltage mode, and the maximum output current is 100 mA when in current mode.
- If you press [2 A], the bias source area will display 2 A, which means that the 2 A bias constant current source is selected, and the bias source can output a maximum of 2 A current in no voltage mode.

The setting here only selects the bias source and cannot set the actual output bias value. The actual output bias value needs to be set in the row where the actual test parameters are located.

For a detailed introduction of the bias source, please refer to the bias description in the LCR measurement setup chapter.

### 6.2.6 Comp

Move the cursor to the Comparison area; the menu area on the right side of the screen will display [OFF] and [ON].

- If you press [OFF], the comparison field will display OFF, which means that the comparison is turned off, and no sorting results will be output during the test. The PASS and FAIL lights on the front panel are off, the comparison column corresponding to the transformer measurement display interface will display "---", and the Handler interface sorting signal line has no sorting signal output.
- If you press [ON], the comparison field will display ON, which means that the comparison is turned on, and the sorting result will be output during the test. The PASS or FAIL light on the front panel will be on, the comparison column corresponding to the transformer measurement display interface will display PASS or FAIL, and the Handler interface sorting signal line has a sorting signal output.

## 6.2.7 Parameter Setup

The parameter setting area is shown in Figure 6-1, with 12 rows and 11 columns.

Each row corresponds to a parameter, and up to 12 parameters can be selected for measurement; each column corresponds to a setting item of the corresponding parameter.

The 11 columns are:

- Parameter
- Frequency
- Level
- Other
- Deviation
- Nominal Value
- Lower Limit
- Upper Limit
- Delay
- Average
- Measurement

The parameter column is to select the parameter that needs to be measured. Move the cursor to the parameter column in each row. There are 16 measurement parameters for selection, namely:

- |      |      |         |
|------|------|---------|
| • Ls | • Rs | • Ns    |
| • Lp | • Rp | • Ns:Np |
| • Lk | • Rd | • Np    |
| • Cs | • D  | • Np:Ns |
| • Cp | • Q  |         |
| • Zx | • dZ |         |

In the menu bar on the right, in addition to the 16 parameters that can be selected, there are [Move Up], [Move Down] and [HELP] options.

- The **Frequency** column is to set the measurement frequency corresponding to each measurement parameter. Rd is the DC test, so the Frequency column corresponding to this parameter is empty.
- The **Level** column is the measurement level corresponding to each measurement parameter.
- The **Other** column is the unique test items for some measurement parameters.
- The four columns of **Deviation**, **Nominal Value**, **Lower Limit** and **Upper Limit** constitute the sorting settings of the parameters. The three options are Deviation Mode,  $\Delta$  and  $\Delta\%$ , which respectively represent data read-only mode, absolute deviation mode, and percentage deviation mode.
- The **Delay** column sets the delay time of the corresponding parameter, this delay time is added before the measurement.
- The **Average** column sets the average times of the corresponding parameters. Increasing the average times can increase the stability of the parameter test.
- The **Measurement** column is the measurement switch of the corresponding parameter. ON means that this parameter is included in the measurement, and OFF means that this parameter will not be measured.

## 6.3 <Single Display>

Press the menu key [DISP] to enter the <Single Display> page. As shown below:

Para	Freq(Hz)	Level(V)	Other	Value	Comp	Display
Rd		1.0000		98.590mΩ	----	Save OFF

Figure 6-2 Single Display

Each row of this page shows the level, frequency, measurement result, sorting result, etc. of each parameter of the transformer. The menu bar on the right side of the screen has [View], [Settings] and [Save] options.

Press [Settings] to navigate to the <Transformer Test Settings> page.

Press [Save] to save the measurement results to the USB flash drive.

### 6.3.1 Save the Measurement Results of a Single Set of Transformers to the USB Flash Drive

Use the USB flash drive to save the measurement results. The results/settings that can be saved are as follows:

- Time
- pt
- para
- val
- COMP

(These correspond, in order, to test time, point index, parameter name, parameter result, comparison result.)

The operation steps to save your data are as follows:

- 1) Choose [Save]
- 2) "Save path" prompt; default path location: "usb/CSV/" path
- 3) The naming rule of the file name is trt+machine number+date, such as trt-SN12345678-20210811.csv.

## 7 Transformer Auto Scanning Test

### 7.1 Introduction to the Scan Measurement Function

ST2840NX can rely on an internal scan board or use an external ST1901/ST1806/ST1831 transformer scan box to form a transformer automatic test system; ST2840AX and ST2840BX can only use an external scan box to form a test system (no internal scan board).

At present, the test items that can be provided in the automatic scanning test of transformers include:

- The Number of Turns (TURN)
- Phase (PHASING)
- Inductance (Lx)
- Quality Factor (Q)
- Leakage Inductance (LK)
- Stray Capacitance (Cx)
- Impedance (Zx)
- AC Impedance (ACR)
- DC Impedance (DCR)
- Balance (BALANCE)
- Short-Circuit Test (PIN-SHORT)
- Current Bias (DCI-BIAS)

etc.

ST2840X can realize the automatic conversion between transformer pins and fixture pins, automatic test time of rescan interval setup, multi-group primary winding test, multi-group leakage test, deviation compensation for test values, PASS and FAIL count for measurement result, save and load function for test parameter, repeat test for FAIL product, etc. Also, it can test several transformers at the same time.

### 7.2 Install and Connect the Scanning Test System

The automatic transformer test system is the connection of ST1901/ST1806/ST2831 and ST2840X, and the connection steps are as follows:

Use 36PIN double-headed cable (ST26016 transformer test control cable) to connect the SCANNER socket on the rear panel of ST1901/ST1806/ST2831 and the SCANNER socket on the rear panel of ST2840X as shown in the following figure.

Warning!	
	<b>Do not</b> plug the cable with electricity! Keep the direction of the cable to be routed correctly.





If it is necessary to use the foot switch, connect the foot switch to the FOOT.C interface on the rear panel of the test fixture.

**Note:** Once the foot switch is used, the [START] button on the test fixture will not work.

<b>Warning!</b>	
	Clean the fixture in time for accurate measurement. Mold the pins of transformers before measurement. Cover the fixture after use to avoid dust.

If the scanning box is ST1901A, connect the trachea to the valve controller.

Connect ST1901L 6-terminal scanning box to the corresponding terminal on the front panel of ST2840X and lock it as shown in the following figure.

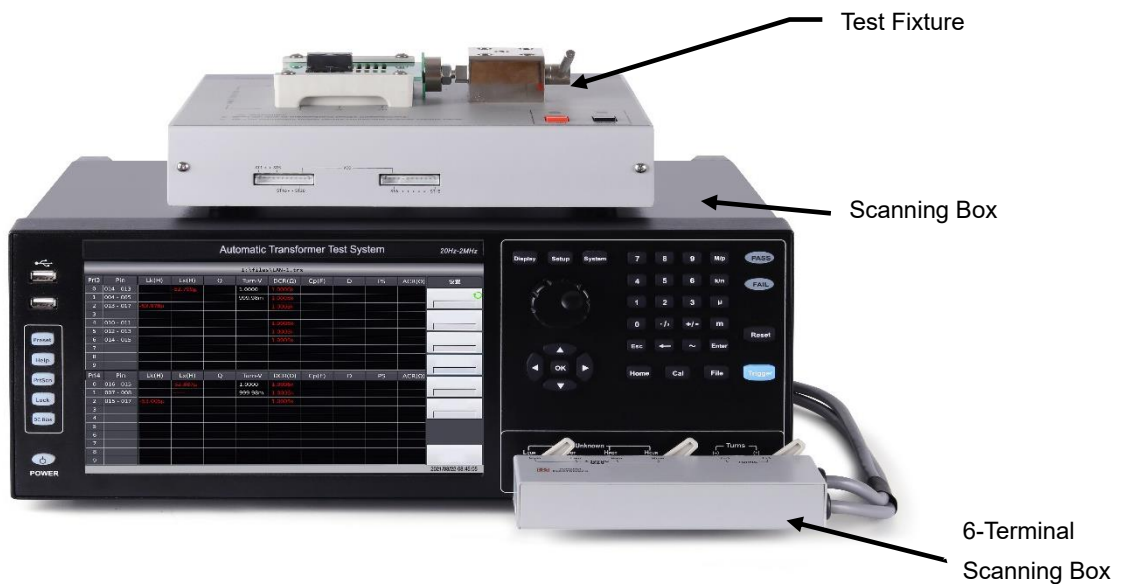

Connect the scanning test cable to ST2840X.

## 7.3 Front Panel of Scanning Box

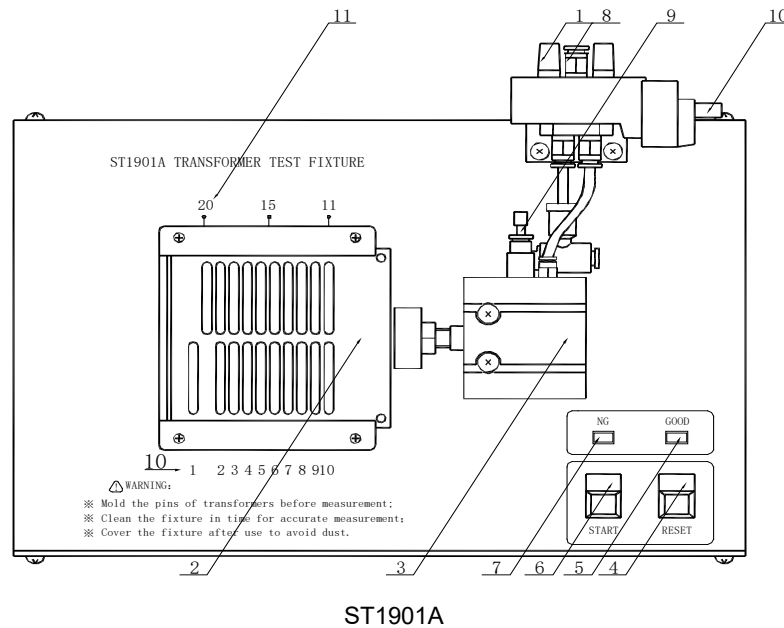

### 7.3.1 Introduction to Each Number on the Front Panel

**1) Silencer**

This is a silencer used for noise reduction and dust proof (only for ST1901A).

**2) Test Fixture**

This fixture is flexible and replaceable.

**3) Cylinder**

This is the main driving force for ST1901A; For ST1901B/ST1831, the motive force is from a manual push rod.

**4) RESET Button**

When pressing this button, all tests will be terminated and the instrument will recover to the original preparing test state.

**5) GOOD Indicator**

If the specified measurement results meet the preset requirements, this indicator will light up, which indicates that the tested device is GOOD.

**6) START Button**

Used to control the test. If you press this button, the instrument will start its measurement.

**7) NG Indicator**

If one or two measurement results cannot meet to the preset requirements, this indicator will light up, which indicates that the tested device is NOT GOOD.

**8) Inlet of the Air Pipe**

This is the connection interface connecting with external air pipe. Note: It is recommended to install a water filtering device between the inlet and the inlet valve so as to improve the service life of the cylinder and the inlet valve. (This inlet is unavailable for ST1901B/ST1831.)

**9) Speed Control Knob**

The knob is used to adjust the driving speed of the cylinder. (Unavailable for ST1901B/ST1831.)

**10) Control Socket of Air Valve Controller (Electromagnetic Valve)**

The switch for controlling ST1901A and the cylinder. The power is DC24V. There is no such controller in ST1901B/ST1831.

**11) Fixture Pin Number**

In the figure above, 1 ~ 20/24 is the corresponding pin number.

**7.4 Rear Panel of Scanning Box**

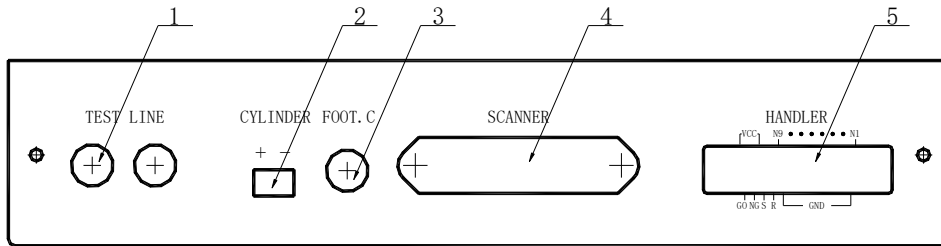

**7.4.1 Introduction to Each Number on the Rear Panel**

**1) Test Line**

Inlet port of the test cable, ST1901L 6-terminal test box is connected to inner part of ST1901A/B through this line.

**2) Cylinder**

24 V DC voltage output terminal, providing the working voltage for ST1901A solenoid valve.

**3) Foot. C**

Used to connect footswitch.

**4) Scanner**

Signal control port. Use ST26016 control cable to connect the scanning box with ST2840X via the Scanner port.

**5) Handler**

Handler port. Refer to chapter 10 for further instructions.

**Note:** There is a hole in the left panel of ST1901A/B; here, the inner adjustable potentiometer can be used to adjust the volume of the beep.

**7.5 Timing Diagram of the Handler Signal**

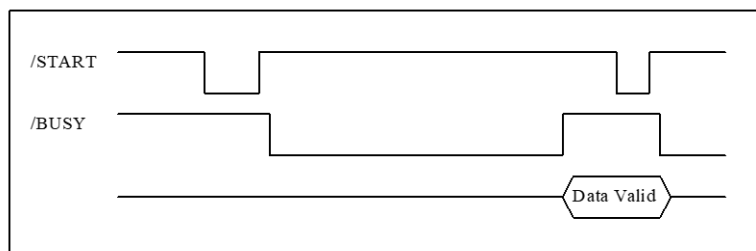

### 7.5.1 Distribution and Connection Diagram for Handler

The distribution and external circuit of Handler signal pin:

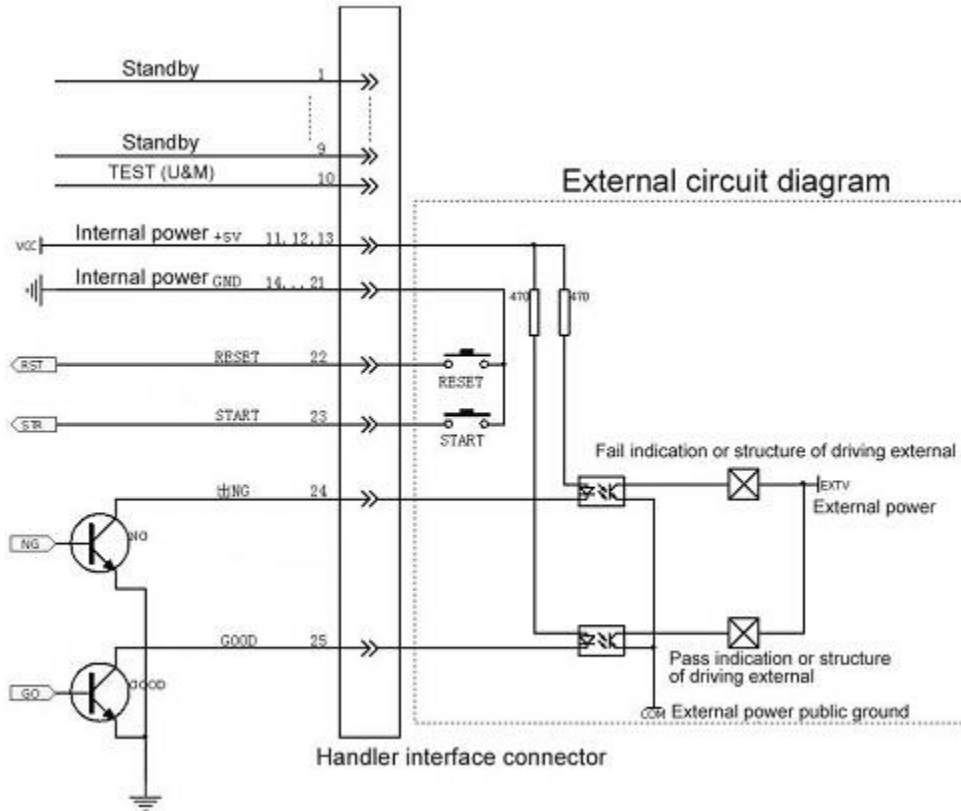

### 7.6 Example of Transformer

In order to understand the operation of a transformer scanning test, the setting figures listed in the following chapters are based on the sample below.

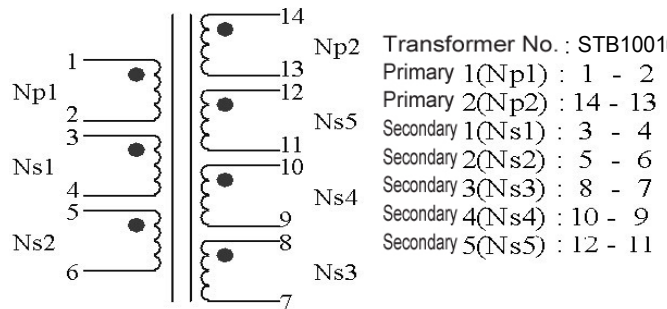

More detailed information will be described in later sections.

### 7.7 Clear Settings

Before configuring new transformer ID measurement settings, you must clear the unpredictable data that may exist in the memory of the instrument and prevent unpredictable errors during the test of the newly configured measurement settings. The method is as follows:

On any transformer sweep function page, press the button [PRESET] on the left side of the front panel to select the function [Clear Settings]. You can also reset the transformer setting parameters by restarting the instrument.

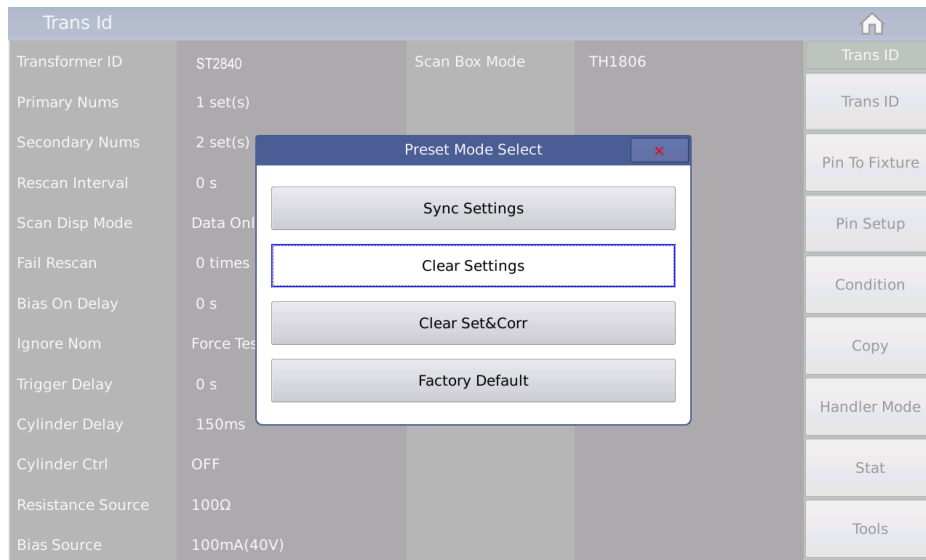

## 7.8 <Transformer ID>

When the instrument function is Trans Scan, press the [SETUP] button above the knob to enter the <Trans ID> page.

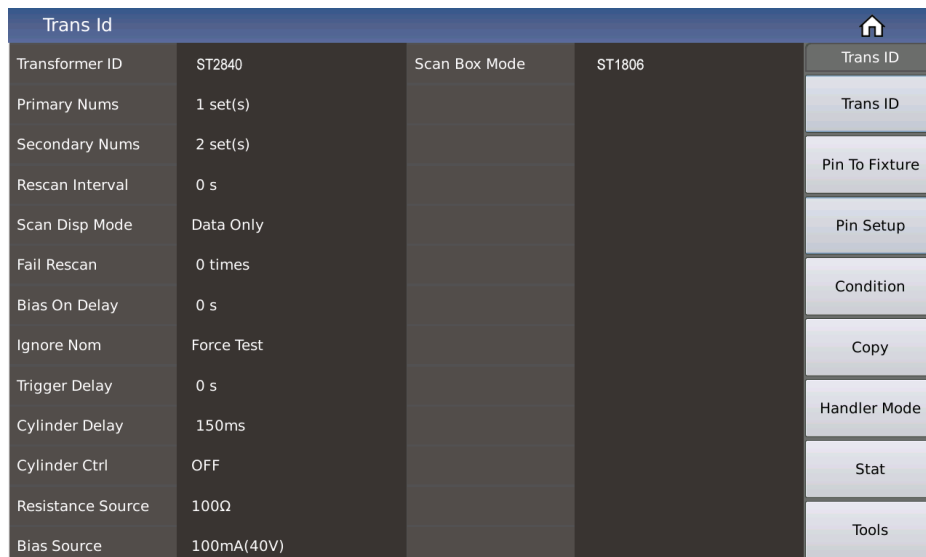

### 7.8.1 Transformer ID

You can input the transformer ID to be measured in this area. The setting method is as follows:

- 1) Press the menu function [Input].
- 2) Select the desired character in the soft keyboard.
- 3) Press [ESC] to cancel or press [ENTER] to apply the entered transformer ID.



## 7.8.2 Primary Numbers

You can input the number of transformer primary groups in this area. For transformers with multiple cores, multiple PRIs may be set.

**Primary Numbers Range:** 1 ~ 60

## 7.8.3 Secondary Numbers

You can input the number of transformer secondary groups in this area.

**Secondary Numbers Range:** 1 ~ 9

## 7.8.4 Rescan Interval

In this area, you can input the interval time for automatic continuous measuring.

**Rescan Interval Range:** 0 ~ 60 s; 0 means no automatic continuous measuring.

## 7.8.5 Scan Disp Mode

This area is used to configure the overall judgement display options, and is used to control the display mode of the results during the scanning test of the transformer. There are 3 modes:

- **Data Mode:** This means that the test data of each parameter is displayed one by one during the scanning process, but there is no general PASS/FAIL large-character display, which is convenient for users to view.
- **Judgement Results Mode:** This means that the test data of each parameter is displayed one by one during the scanning process, and the total PASS/FAIL is displayed in large characters after it is finished.
- **Fail List:** This means that the test data of each parameter is displayed one by one during the scanning process, and the unqualified parameters and their limit settings are displayed in the center of the screen after it is finished.

## 7.8.6 Fail Rescan

This area is used to configure the number of retests for defective products. It is used to set the number of retests in order to prevent a certain parameter from being defective due to interference during the automatic scanning test process, thereby increasing the yield of good products.

**Rescan Range of Defective Products:** 0 ~ 9 times

## 7.8.7 Bias on Delay

This area is used to configure the delay when applying DC current bias test.

**Current Bias Delay Range:** 0 ~ 60 s; 0 s means no delay.

## 7.8.8 Ignore Nom

This area incorporates 2 functions; one is to ignore the nominal value for measuring, and the other is the deviation deduction limit. All are related to the nominal value. They are as follows:

- **FORCE DEV:** When this option is selected, you will not be restricted by the set nominal value (STD) when deducting deviation. That is, it can be deducted when the deviation between the test value and the set nominal value (STD) is large, for example if you insert the wrong pin of the transformer.
- **FORCE TEST:** When this option is selected, as long as the winding pin is set, the parameter to be tested for the winding can be measured without setting the nominal value. This can be convenient in order to measure and observe when you do not know the nominal value of the transformer sample. This option is, however, most often not used.
- **SKIP TEST LMTED DEV:** When this option is selected, it means that the pin position of the winding is set but the nominal value of the parameter to be tested is not set; thus the parameter to be tested will not be measured during the test. The mode will be limited by the nominal value when the deviation is deducted. If your test value deviates greatly from the set nominal value (STD), the deduction will not succeed.

## 7.8.9 Trigger Delay

This area is used to configure the delay time from when the instrument is triggered to the start of the sweep test.

**Delay Range:** 0 ~ 60 s; 0 means no delay.

## 7.8.10 Cylinder CTRL

This area is used to configure the switch of cylinder 24 V power.

- **ON:** Output of 24 V cylinder power is enabled during scanning.
- **OFF:** Output of 24 V cylinder power is disabled during scanning.
- **FAIL HOLD:** The test is stopped when a defective product is encountered during scanning.
- **FAIL LOCK:** The test is stopped when a defective product is encountered during scanning, and the system is locked.

### 7.8.11 Scan Box Mode

This area is used to configure the test fixture used when the instrument scans.

- **Internal:** This means that the internal scanning board of the instrument is used in the test (ST2840NX only).
- **ST1831:** This means that the ST1831 scan box is used in the test.
- **ST1806:** This means that the ST1806 scan box is used in the test, which is compatible with the ST1901 scan box.

**Note:** This function needs to be set in accordance with the fixture used. Inconsistent configuration will cause the instrument to fail to obtain correct measurement results.

### 7.8.12 Resistance Source

ST2840X provides two output resistances to choose from: 100 Ω or 30 Ω.

When measuring inductance, in order to compare data with other types of testers, it is necessary to ensure the same output resistance value. When measuring some magnetic cores with very high permeability, use 100 Ω internal resistance to reduce the degree of polarization of the magnetic core, which can improve the accuracy and stability of the test.

**Note:** When using bias current output, the default value is 100 Ω.

### 7.8.13 Bias Source

The bias source function is used to select the DC bias source used by the instrument. The transformer scan only provides two bias sources as follows:

- **100 mA (40 V) Mode:** The transformer scan test uses a DC bias source (0 mA ~ 100 mA).
- **2 A Mode:** The transformer scan test uses a DC bias source (0 A ~ 2 A).

**Note:** When the DC bias source is enabled, only 100 Ω output resistance can be used!

## 7.9 Trans Pin to Fixture

On the <Trans ID> page, press the menu key [Trans Pin], it will jump to the <Trans Pin To Fixture> page. This page is used to connect the pin of the transformer to the pin of the test fixture, and to convert the pin number into a custom pin label.

Trans Pin To Fixture													Home									
[A] + [B]		[C] + [D]				[E] + [F]				[G] + [H]				[I] + [J]				[K] + [L]				Trans Pin
	FRC [A]	A01	A02	A03	A04	A05	A06	A07	A08	A09	A10	A11	A12	Allocate Auto Clear FRC Pins Clear All FRC Pins								
	Trans Pin	001	002	003	004	005	006	007	008	009	010	011	012									
	Pin Label	001	002	003	004	005	006	007	008	009	010	011	012									
	FRC [A]	A13	A14	A15	A16	A17	A18	A19	A20	A21	A22	A23	A24									
	Trans Pin	013	014	015	016	017	018	019	020	021	022	023	024									
	Pin Label	013	014	015	016	017	018	019	020	021	022	023	024									
	FRC [B]	B01	B02	B03	B04	B05	B06	B07	B08	B09	B10	B11	B12	Allocate Auto Clear FRC Pins Clear All FRC Pins								
	Trans Pin	025	026	027	028	029	030	031	032	033	034	035	036									
	Pin Label	025	026	027	028	029	030	031	032	033	034	035	036									
	FRC [B]	B13	B14	B15	B16	B17	B18	B19	B20	B21	B22	B23	B24									
	Trans Pin	037	038	039	040	041	042	043	044	045	046	047	048									
	Pin Label	037	038	039	040	041	042	043	044	045	046	047	048									



### 7.9.1 Pin-to-Fixture Setup

The default state when the instrument is turned on is such that the transformer pins correspond to the fixture pins one-to-one. Normally, when using the internal scanning board of the instrument, you only need to connect the transformer pins to the fixture pins on the rear panel of the instrument one-to-one and it can be measured.

The external scanning test box (ST1831, ST1806, etc.) can be connected according to 1 ~ 20/24 marked on the front of the test box. If you use the above setting method, you can skip the pin to fixture setup here. The figure below is the corresponding relationship between the sample transformer pin 1 and the fixture pin 2.

The manual setting method is as follows:

- 1) Click any cell of the transformer pin in the table, the menu bar will display related menu functions;
- 2) Select the function to [Clear All FRC Pins] to clear the default settings;
- 3) Press the function key to [Allocate] and change the Allocate function option from Auto to Manual.
- 4) When manually allocating, move the cursor to the corresponding fixture pin position and input the corresponding transformer pin.





**Note:** Input "0" to clear the corresponding pin input.

When the Allocate function is set to Auto, it will automatically +1 the number of pins at the transformer pin where the first number is entered, until the input box of the last transformer pin.

Trans Pin To Fixture													 Trans Pin			
[A] + [B]	[C] + [D]		[E] + [F]		[G] + [H]		[I] + [J]		[K] + [L]				Allocate	Manual		
 FRC [A] A01 A02 A03 A04 A05 A06 A07 A08 A09 A10 A11 A12 Trans Pin Pin Label 001 002 003 004 005 006 007 008 009 010 011 012 FRC [A] A13 A14 A15 A16 A17 A18 A19 A20 A21 A22 A23 A24 Trans Pin Pin Label 013 014 015 016 017 018 019 020 021 022 023 024																
			001	002	003	004	005	006	007							
			001	002	003	004	005	006	007	008	009	010	011	012		
			008	009	010	011	012	013	014							
 FRC [B] B01 B02 B03 B04 B05 B06 B07 B08 B09 B10 B11 B12 Trans Pin Pin Label 025 026 027 028 029 030 031 032 033 034 035 036 FRC [B] B13 B14 B15 B16 B17 B18 B19 B20 B21 B22 B23 B24 Trans Pin Pin Label 037 038 039 040 041 042 043 044 045 046 047 048																
			025	026	027	028	029	030	031	032	033	034	035	036		
			037	038	039	040	041	042	043	044	045	046	047	048		

### 7.9.2 Pin Label Setup

The transformer pin label function can convert a transformer pin that was originally only represented by numbers into a transformer pin represented by custom numbers or letters, as shown below:

Trans Pin To Fixture													Pin Label	
[A] + [B]	[C] + [D]		[E] + [F]		[G] + [H]		[I] + [J]		[K] + [L]				Input	
	FRC [A]	A01	A02	A03	A04	A05	A06	A07	A08	A09	A10	A11	A12	Default Item Label
	Trans Pin		001	002	003	004	005	006	007					
	Pin Label	P01	P02	P11	P12	P21	P22	P32	P31	P42	P41	P52	P51	
	FRC [A]	A13	A14	A15	A16	A17	A18	A19	A20	A21	A22	A23	A24	Default FRC Labels
	Trans Pin	008	009	010	011	012	013	014						
	Pin Label	P62	P61	015	016	017	018	019	020	021	022	023	024	
	FRC [B]	B01	B02	B03	B04	B05	B06	B07	B08	B09	B10	B11	B12	Default All FRC Labels
	Trans Pin													
	Pin Label	025	026	027	028	029	030	031	032	033	034	035	036	
	FRC [B]	B13	B14	B15	B16	B17	B18	B19	B20	B21	B22	B23	B24	
	Trans Pin													
	Pin Label	037	038	039	040	041	042	043	044	045	046	047	048	

After setting the transformer pin label and related measurement conditions, it can be displayed in the PIN (pin) column in the transformer measurement interface as a custom transformer pin label (to be updated).

### 7.10 Pin Setup

Press the function key [Pin Setup] on the <Trans ID> page, and it will go to the <Trans Pin> page. This page is used to set the pins of each winding of the transformer, connect the pins in series, and connect in parallel. Please see the following example transformer and its pin setting screen:

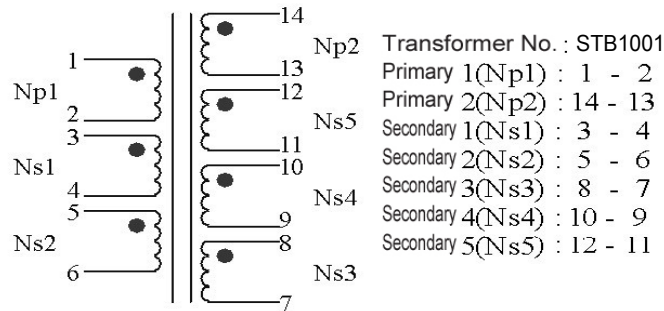

### 7.10.1 Trans Pin Setup

The following is the pin setting screen of PRI: A1 (PRI: A1 is used for Np1 as the primary winding):

Trans Pin										Trans Pins			
Phase	Trans Pins		Series Pins		Parallel Pins					+	-		
	+	-	+	-									
<b>PRI.</b>	P61	P62										PRI.	↻
												A2	
SEC. 1	P11	P12										Clear Trans Pins	
SEC. 2	P21	P22										Clear Page	
SEC. 3	P31	P32											
SEC. 4	P41	P42											
SEC. 5	P51	P52											
SEC. 6													
SEC. 7													
SEC. 8													
SEC. 9													

The following is the pin setting screen of PRI: A2 (PRI: A2 is used for Np2 as the primary winding):

Trans Pin										Trans Pins			
Phase	Trans Pins		Series Pins		Parallel Pins					+	-		
	+	-	+	-									
<b>PRI.</b>	P01	P02										PRI.	↻
												A1	
SEC. 1	P11	P12										Clear Trans Pins	
SEC. 2	P21	P22										Clear Page	
SEC. 3	P31	P32											
SEC. 4	P11	P22											
SEC. 5	P11	P12											
SEC. 6													
SEC. 7													
SEC. 8													
SEC. 9													

### 7.10.2 Series Pins Setup

Before configuring the transformer series pin, you need to confirm the parameters of the series measurement. For example, the Lx inductance needs to set the series pin. You can select the function Lx in the parameter menu bar, and then input the series pin.

The following is the short-circuit pin setting when series transformers Ns1 and Ns2 test Lx.

Trans Pin							Series Pins	
Phase	Trans Pins		Series Pins		Parallel Pins		Series Pins	
	+	-	+	-	+	-	PRI.	Para
PRI.	P01	P02					A1	Lx
SEC. 1	P11	P12						
SEC. 2	P21	P22						
SEC. 3	P31	P32						
<b>SEC. 4</b>	P11	P22	P12	P21				
SEC. 5	P11	P12						
SEC. 6								
SEC. 7								
SEC. 8								
SEC. 9								

The following is the short-circuit pin setting when series transformers Ns1 and Ns2 test TURN.

Trans Pin							Series Pins	
Phase	Trans Pins		Series Pins		Parallel Pins		Series Pins	
	+	-	+	-	+	-	PRI.	Para
PRI.	P01	P02					A1	Turn
SEC. 1	P11	P12						
SEC. 2	P21	P22						
SEC. 3	P31	P32						
<b>SEC. 4</b>	P11	P22	P12	P21				
SEC. 5	P11	P12						
SEC. 6								
SEC. 7								
SEC. 8								
SEC. 9								

### 7.10.3 Parallel Pins Setup

Before setting the transformer parallel pins, you need to confirm the parameters for parallel measuring. For example, the TURN ratio needs to set the parallel pins. You can select the function [Turn] in the parameter menu bar, and then input the parallel pins.

The following figure shows the short pin setup of the "+" and "-" terminal when example parallel transformers Ns1 and Ns2 tests:

Trans Pin										Parallel Pins
Phase	Trans Pins		Series Pins		Parallel Pins					PRI.
	+	-	+	-	+			-		
PRI.	P01	P02								A1
SEC. 1	P11	P12								
SEC. 2	P21	P22								
SEC. 3	P31	P32								
SEC. 4	P11	P22	P12	P21						
SEC. 5	P11	P12			P21			P22		
SEC. 6										
SEC. 7										
SEC. 8										
SEC. 9										

## 7.11 <Trans Condition>

This page contains two tables:

The **upper table** is the parameter settings table, which is mainly used to set the parameters and measurement settings of the transformer under test. The parameters that can be measured are:

- Turn (number of turns)
- Phase (phase)
- Lx (inductance)
- Q (quality factor)
- Lk (leakage inductance)
- Cx (distributed capacitance between turns)
- D (loss)
- Zx (Impedance)
- ACR (AC resistance)
- DCR (DC resistance)
- PS (pin short-circuit detection)
- BAL (balance)

You can also change the scan order of each parameter and set the measurement frequency, test voltage, test mode, etc. of each parameter.

The **lower table** is the parameter limit setting table, which is mainly used to set the nominal value and upper and lower limits of each parameter for sorting.

Trans Condition									
	Turn	Lx	Lk	Cx	Zx	ACR	DCR	PS	BAL
Freq(Hz)	10.0000k	10.0000k	10.0000k	10.0000k	10.0000k	10.0000k			
Level	1 V	300mV	300mV	300mV	300mV	300mV	2 V	2 V	
Dev	OFF	OFF	OFF	OFF	OFF	OFF	OFF		
Average	1	1	1	1	1	1	1	1	
Delay	0 s	0 s	0 s	0 s	0 s	0 s	0 s	0 s	
Equ		Series	Series	Parallel		Series			
Sequence	1	2	3	4	5	6	7	8	9
Switch	ON	ON	ON	ON	ON	ON	ON	ON	ON

Turn	Pins	Phase	Std(T)	Low	High	Short Pins
0	P01-P02	+	1.0000			
1	P11-P12	+				
2	P21-P22	+				
3	P31-P32	+				
4	P11-P22	+				
5	P11-P12	+				
6		+				
7		+				
8		+				
9		+				

### 7.11.1 Frequency, Voltage, Switch and Scanning Sequence

There are multiple parameter variables corresponding to each parameter: frequency, level, deviation, average, delay, equivalence, scan sequence and switch. Touch or move the cursor to the corresponding setting area and modify the corresponding parameters according to the menu prompts to meet user needs.

**Frequency Range:** 20 Hz ~ 2 MHz

**Measurement Level:** 5 mV ~ 20 V

**Deviation:** OFF or  $\Delta\%$ ; this parameter is used to set the sorting method, the same as the limit mode of ST2829X series.

- **OFF:** The measurement results are sorted directly according to the set upper and lower limits.
- **$\Delta\%$ :** The difference between the test value and the nominal value divided by the nominal value will be sorted according to the set upper and lower limits.

**Average Times:** 1 ~ 255. Perform multiple tests according to the set average times, and display the results after calculating the average value. This function can also be used to adjust the measurement speed of a single parameter.

**Delay:** 0 ~ 60 s, the delay between the trigger test and the test. This function can improve the stability and accuracy of the test.

**Equivalence:** Series, parallel

**Sequence:** The default number of the scanning sequence is 1 ~ 9 from left to right, you can enter the number 1 ~ 8 to change, and BAL is fixed as the last item 9.

**Switch:** If you choose ON, the corresponding parameter is active, otherwise the corresponding parameter is inactive.

## 7.11.2 Turn Measurement Conditions Setup

On the <Trans Condition> page, touch or move the cursor to the Turn column of the measurement settings table to set the Turn parameters.

Trans Condition										Turn	
Freq(Hz)	10.0000k	10.0000k	10.0000k	10.0000k	10.0000k	10.0000k					PRI.
Level	1 V	300mV	300mV	300mV	300mV	300mV	2 V	2 V			A1
Dev	OFF	OFF	OFF	OFF	OFF	OFF	OFF	OFF			Turn Mode ▶
Average	1	1	1	1	1	1	1	1			Turn_V
Delay	0 s	0 s	0 s	0 s	0 s	0 s	0 s	0 s			
Equ		Series	Series	Parallel		Series					
Sequence	1	2	3	4	5	6	7	8	9		
Switch	ON	ON	ON	ON	ON	ON	ON	ON	ON		
Turn	Pins	Phase	Std(T)	Low	High	Short Pins					
0	P01-P02	+	1.0000								
1	P11-P12	+									
2	P21-P22	+									
3	P31-P32	+									
4	P11-P22	+									
5	P11-P12	+									
6		+									
7		+									
8		+									
9		+									

### 7.11.2.1 Turn Mode

When touching the Turn setting area or moving the cursor to the Turn setting area, the Turn mode can be set in the menu on the right.

Turn can choose the following 8 modes:

- **Turn\_v** = primary standard value × secondary voltage / primary voltage  
This mode is used to measure the transformer turn number.
- **Turn** = primary standard value × secondary turn/primary turn  
When the primary inductance is small, using this mode can test the turn number more accurately. But when measuring magnetic core with high magnetic conductivity the data will be unstable in this mode due to the polarized magnetic core.
- **Volt** = primary test voltage × secondary voltage / primary voltage
- **Vs:Vp** = secondary voltage / primary voltage
- **Ns:Np** = secondary turn / primary turn
- **Turn\_L** = inductance ratio mode
- **Np:Ns** = primary turn / secondary turn
- **Lp:Ls** = primary inductance / secondary inductance

It is recommended to put the windings with multi-turns in the primary turn ratio; the reasons are as follows:

- By the influence of output internal resistance (30 Ω; 100 Ω), when the primary inductance is small, the distributed voltage signal will also be small and the energy the transformer gets is therefore weak. The test cable and the relay will attenuate a part of the energy, so stability and accuracy will be affected.
- If the primary signal is forcibly enlarged, then the voltage generated by secondary multi-winding will be high and it may be over the range of the instrument and thus further affect the test accuracy.
- If the winding with multi-turns is put in primary test, then the energy of the transformer will be strong and the two problems above can be ignored.

Trans Condition										Turn	
Freq(Hz)	Turn	Lx	Lk	Cx	Zx	ACR	DCR	PS	BAL		Turn
Level	10.0000k	10.0000k	10.0000k	10.0000k	10.0000k	10.0000k					Turn
Dev	1 V	300mV	300mV	300mV	300mV	300mV	2 V	2 V			Volt
Average	OFF	OFF	OFF	OFF	OFF	OFF	OFF	OFF			Ns:Np
Delay	1	1	1	1	1	1	1	1			Vs:Vp
Equ	0 s	0 s	0 s	0 s	0 s	0 s	0 s	0 s			Turn_V
Sequence		Series	Series	Parallel		Series					Np:Ns
Switch	1	2	3	4	5	6	7	8	9		Turn_L
	ON	ON	ON	ON	ON	ON	ON	ON	ON		Lp:Ls
Turn	Pins	Phase	Std(T)	Low	High	Short Pins					Return
0	P01-P02	+	1.0000								
1	P11-P12	+									
2	P21-P22	+									
3	P31-P32	+									
4	P11-P22	+									
5	P11-P12	+									
6		+									
7		+									
8		+									
9		+									

### 7.11.2.2 Turn Limits Setup

The Turn limit setting table is used to configure the nominal value, upper and lower limits, phase and short-circuit pins of each winding of the transformer.

Touch the Turn limit setting table, or move the cursor to the Turn limit setting area, and use the number keys, the corresponding magnification and the [ENTER] key to configure.

The magnification options corresponding to Turn are M, k, μ, m, and the [ENTER] key is x1.

Trans Condition										Turn	
Freq(Hz)	Turn	Lx	Lk	Cx	Zx	ACR	DCR	PS	BAL		Turn
Level	10.0000k	10.0000k	10.0000k	10.0000k	10.0000k	10.0000k					PRI.
Dev	1 V	300mV	300mV	300mV	300mV	300mV	2 V	2 V			A1
Average	OFF	OFF	OFF	OFF	OFF	OFF	OFF	OFF			Turn Mode
Delay	1	1	1	1	1	1	1	1			Turn_V
Equ	0 s	0 s	0 s	0 s	0 s	0 s	0 s	0 s			Clear Turn Table
Sequence		Series	Series	Parallel		Series					Copy ↓ ↓
Switch	1	2	3	4	5	6	7	8	9		
	ON	ON	ON	ON	ON	ON	ON	ON	ON		
Turn	Pins	Phase	Std(T)	Low	High	Short Pins					
0	P01-P02	+	1.0000								
1	P11-P12	+	200.00	198.00	202.00						
2	P21-P22	+									
3	P31-P32	+									
4	P11-P22	+									
5	P11-P12	+									
6		+									
7		+									
8		+									
9		+									

### 7.11.2.3 Turn Phase Setup

When setting the limit of the number of turns, you can set the secondary winding phase for sorting; "+" means the same direction, and "-" means the opposite direction.

The phase of the primary winding is used as the reference phase and cannot be modified. When the measured phase of the secondary winding is inconsistent with the phase set here, it will be judged as unqualified.

The default setting of the instrument is opposite to the primary phase, which means the phase is unqualified.



Trans Condition										Turn
	Turn	Lx	Lk	Cx	Zx	ACR	DCR	PS	BAL	
Freq(Hz)	10.0000k	10.0000k	10.0000k	10.0000k	10.0000k	10.0000k				
Level	1 V	300mV	300mV	300mV	300mV	300mV	2 V	2 V		
Dev	OFF	OFF	OFF	OFF	OFF	OFF	OFF	OFF		
Average	1	1	1	1	1	1	1	1		
Delay	0 s	0 s	0 s	0 s	0 s	0 s	0 s	0 s		
Equ		Series	Series	Parallel		Series				
Sequence	1	2	3	4	5	6	7	8	9	
Switch	ON	ON	ON	ON	ON	ON	ON	ON	ON	

Turn	Pins	Phase	Std(T)	Low	High	Short Pins
0	P01-P02	+	1.0000			
1	P11-P12	-	200.00	198.00	202.00	
2	P21-P22	+				
3	P31-P32	+				
4	P11-P22	+				
5	P11-P12	+				
6		+				
7		+				
8		+				
9		+				

### 7.11.2.4 Turn Ratio Short Pins

When setting the Turn ratio short pins, you can use soft keys . and ~ to input multiple pins; the maximum number of pins that can be saved here is 48.

**Example:**

- 1) Input a discontinuous number "1, 3, 5, 7, 9" and press the soft key . to separate each number; press [ENTER] to confirm. The final data displayed in the table is (1, 3, 5, 7, 9).
- 2) Input a continuous number of "1, 2, 3, 4, 5, 6, 7, 8, 9": first input the number "1", then press the soft key ~ , finally input "9". Press [ENTER] to confirm. The final data displayed in the table is (1 ~ 9).

**Note:** The maximum number of turns ratio short pins is 48 and some pins after the excess will be ignored.

- 3) Input part of continuous numbers and discontinuous numbers "1, 2, 3, 4, 5, 7, 9" (the continuous part is the same as step 2, the discontinuous part is the same as step 1); press [ENTER] to confirm. The final data displayed in the table is (1 ~ 5,7,9).

Trans Condition										Turn
	Turn	Lx	Lk	Cx	Zx	ACR	DCR	PS	BAL	
Freq(Hz)	10.0000k	10.0000k	10.0000k	10.0000k	10.0000k	10.0000k				
Level	1 V	300mV	300mV	300mV	300mV	300mV	2 V	2 V		
Dev	OFF	OFF	OFF	OFF	OFF	OFF	OFF	OFF		
Average	1	1	1	1	1	1	1	1		
Delay	0 s	0 s	0 s	0 s	0 s	0 s	0 s	0 s		
Equ		Series	Series	Parallel		Series				
Sequence	1	2	3	4	5	6	7	8	9	
Switch	ON	ON	ON	ON	ON	ON	ON	ON	ON	

Turn	Pins	Phase	Std(T)	Low	High	Short Pins
0	P01-P02	+	1.0000			
1	P11-P12	-	50.000	48.000	52.000	P21~P31
2	P21-P22	+	50.000	48.000	52.000	
3	P31-P32	+	30.000	28.000	32.000	
4	P11-P22	+	100.00	96.000	104.00	
5	P11-P12	+				
6		+				
7		+				
8		+				
9		+				

### 7.11.3 Lx Measurement Conditions Setup

On the <Trans Condition> page, touch or move the cursor to the Lx column of the measurement conditions table to set the Lx parameters.

Trans Condition										Home
	Turn	<b>Lx</b>	Lk	Cx	Zx	ACR	DCR	PS	BAL	
Freq(Hz)	10.0000k	10.0000k	10.0000k	10.0000k	10.0000k	10.0000k				
Level	1 V	300mV	300mV	300mV	300mV	300mV	2 V	2 V		
Dev	OFF	OFF	OFF	OFF	OFF	OFF	OFF			
Average	1	1	1	1	1	1	1	1		
Delay	0 s	0 s	0 s	0 s	0 s	0 s	0 s	0 s		
Equ		Series	Series	Parallel		Series				
Sequence	1	2	3	4	5	6	7	8	9	
Switch	ON	ON	ON	ON	ON	ON	ON	ON	ON	ON

Lx	Pins	Std(H)	Low	High	Bias	Freq(Hz)	Level	Q-STD	Q-Low	Q-High
0	P01-P02									
1	P11-P12									
2	P21-P22									
3	P31-P32									
4	P11-P22									
5	P11-P12									
6										
7										
8										
9										

#### 7.11.3.1 Lx Limit Setup

The Lx limit setting table is used to configure the Lx standard value, upper and lower limits, bias, multi-frequency, multi-level, Q standard value and Q upper and lower limits of each transformer winding.

Touch the Lx limit setting table, or move the cursor to the Lx limit setting area, and use the number keys, the corresponding magnification and the [ENTER] key to configure.

The magnification options corresponding to Lx are p, n,  $\mu$ , m, and the [ENTER] key is x1.

Trans Condition										Home
	Turn	<b>Lx</b>	Lk	Cx	Zx	ACR	DCR	PS	BAL	
Freq(Hz)	10.0000k	10.0000k	10.0000k	10.0000k	10.0000k	10.0000k				
Level	1 V	300mV	300mV	300mV	300mV	300mV	2 V	2 V		
Dev	OFF	$\Delta\%$	OFF	OFF	OFF	OFF	OFF			
Average	1	1	1	1	1	1	1	1		
Delay	0 s	0 s	0 s	0 s	0 s	0 s	0 s	0 s		
Equ		Series	Series	Parallel		Series				
Sequence	1	2	3	4	5	6	7	8	9	
Switch	ON	ON	ON	ON	ON	ON	ON	ON	ON	ON

Lx	Pins	Std(H)	Low	<b>High</b>	Bias	Freq(Hz)	Level	Q-STD	Q-Low	Q-High
0	P01-P02	1.0000m	-5.0000	5.0000						
1	P11-P12	300.00 $\mu$	-5.0000	5.0000						
2	P21-P22	300.00 $\mu$	-5.0000	5.0000						
3	P31-P32	220.00 $\mu$	-5.0000	5.0000						
4	P11-P22	1.0000m	-5.0000	5.0000						
5	P11-P12	300.00 $\mu$	-5.0000	5.0000						
6										
7										
8										
9										

### 7.11.3.2 Add DC Bias to Lx

The instrument can use a built-in DC bias source of 100 mA or 2 A. When setting the current value, you can set a maximum value of 2 A for the sake of compatibility of storage files.

Trans Condition										Lx
	Turn	Lx	Lk	Cx	Zx	ACR	DCR	PS	BAL	
Freq(Hz)	10.0000k	10.0000k	10.0000k	10.0000k	10.0000k	10.0000k				
Level	1 V	300mV	300mV	300mV	300mV	300mV	2 V	2 V		
Dev	OFF	Δ%	OFF	OFF	OFF	OFF	OFF			
Average	1	1	1	1	1	1	1	1		
Delay	0 s	0 s	0 s	0 s	0 s	0 s	0 s	0 s		
Equ		Series	Series	Parallel		Series				
Sequence	1	2	3	4	5	6	7	8	9	
Switch	ON	ON	ON	ON	ON	ON	ON	ON	ON	

Lx	Pins	Std(H)	Low	High	Bias	Freq(Hz)	Level	Q-STD	Q-Low	Q-High
0	P01-P02	1.0000m	-5.0000	5.0000	8mA					
1	P11-P12	300.00μ	-5.0000	5.0000						
2	P21-P22	300.00μ	-5.0000	5.0000						
3	P31-P32	220.00μ	-5.0000	5.0000	8mA					
4	P11-P22	1.0000m	-5.0000	5.0000						
5	P11-P12	300.00μ	-5.0000	5.0000						
6										
7										
8										
9										

### 7.11.3.3 Lx Multi-Frequency Setup

If you need to use different frequencies to measure different Lx pins of the transformer, in the transformer Lx limit setting table, touch or move the cursor to the Lx frequency area. After inputting the frequency in this area, the frequency here will be automatically used during the test. If the parameter is not configured, the frequency of Lx in the measurement conditions table will be used.

Trans Condition										Lx
	Turn	Lx	Lk	Cx	Zx	ACR	DCR	PS	BAL	
Freq(Hz)	10.0000k	10.0000k	10.0000k	10.0000k	10.0000k	10.0000k				
Level	1 V	300mV	300mV	300mV	300mV	300mV	2 V	2 V		
Dev	OFF	Δ%	OFF	OFF	OFF	OFF	OFF			
Average	1	1	1	1	1	1	1	1		
Delay	0 s	0 s	0 s	0 s	0 s	0 s	0 s	0 s		
Equ		Series	Series	Parallel		Series				
Sequence	1	2	3	4	5	6	7	8	9	
Switch	ON	ON	ON	ON	ON	ON	ON	ON	ON	

Lx	Pins	Std(H)	Low	High	Bias	Freq(Hz)	Level	Q-STD	Q-Low	Q-High
0	P01-P02	1.0000m	-5.0000	5.0000	8mA					
1	P11-P12	300.00μ	-5.0000	5.0000						
2	P21-P22	300.00μ	-5.0000	5.0000						
3	P31-P32	220.00μ	-5.0000	5.0000	8mA					
4	P11-P22	1.0000m	-5.0000	5.0000						
5	P11-P12	300.00μ	-5.0000	5.0000		20.0000k				
6										
7										
8										
9										

### 7.11.3.4 Lx Multi-Level Setup

If you need to use different levels to measure different Lx pins of the transformer, in the transformer Lx limit setting table, touch or move the cursor to the Lx level area. After inputting the level in this area, the test will automatically use this. If the parameter is not configured, the Lx level in the measurement conditions table will be used.

Trans Condition										Home
Turn	Lx	Lk	Cx	Zx	ACR	DCR	PS	BAL		Lx
Freq(Hz)	10.0000k	10.0000k	10.0000k	10.0000k	10.0000k	10.0000k				PRI.
Level	1 V	300mV	300mV	300mV	300mV	300mV	2 V	2 V		A1
Dev	OFF	Δ%	OFF	OFF	OFF	OFF	OFF			Clear Lx Table
Average	1	1	1	1	1	1	1	1		Copy ↓ ↓
Delay	0 s	0 s	0 s	0 s	0 s	0 s	0 s	0 s		
Equ		Series	Series	Parallel		Series				
Sequence	1	2	3	4	5	6	7	8	9	
Switch	ON	ON	ON	ON	ON	ON	ON	ON	ON	

Lx	Pins	Std(H)	Low	High	Bias	Freq(Hz)	Level	Q-STD	Q-Low	Q-High
0	P01-P02	1.0000m	-5.0000	5.0000	8mA					
1	P11-P12	300.00μ	-5.0000	5.0000			500mV			
2	P21-P22	300.00μ	-5.0000	5.0000						
3	P31-P32	220.00μ	-5.0000	5.0000	8mA					
4	P11-P22	1.0000m	-5.0000	5.0000						
5	P11-P12	300.00μ	-5.0000	5.0000		20.0000k				
6										
7										
8										
9										

### 7.11.3.5 Q Limit Setup

On the <Trans Condition> page, touch or move the cursor to the Q-STD, Q-Low and Q-High to configure.

**Note:** The Q value test switch is set at the Lx switch.

Trans Condition										Home
Turn	Lx	Lk	Cx	Zx	ACR	DCR	PS	BAL		Lx
Freq(Hz)	10.0000k	10.0000k	10.0000k	10.0000k	10.0000k	10.0000k				PRI.
Level	1 V	300mV	300mV	300mV	300mV	300mV	2 V	2 V		A1
Dev	OFF	Δ%	OFF	OFF	OFF	OFF	OFF			Clear Lx Table
Average	1	1	1	1	1	1	1	1		Copy ↓ ↓
Delay	0 s	0 s	0 s	0 s	0 s	0 s	0 s	0 s		
Equ		Series	Series	Parallel		Series				
Sequence	1	2	3	4	5	6	7	8	9	
Switch	ON	ON	ON	ON	ON	ON	ON	ON	ON	

Lx	Pins	Std(H)	Low	High	Bias	Freq(Hz)	Level	Q-STD	Q-Low	Q-High
0	P01-P02	1.0000m	-5.0000	5.0000	8mA			10.000	9.0000	
1	P11-P12	300.00μ	-5.0000	5.0000			500mV	10.000	9.0000	
2	P21-P22	300.00μ	-5.0000	5.0000				10.000	9.0000	
3	P31-P32	220.00μ	-5.0000	5.0000	8mA			10.000	9.0000	
4	P11-P22	1.0000m	-5.0000	5.0000						
5	P11-P12	300.00μ	-5.0000	5.0000		20.0000k				
6										
7										
8										
9										

### 7.11.4 Lk Measurement Conditions Setup

On the <Trans Condition> page, touch or move the cursor to the Lk column of the measurement conditions table to configure the Lk parameters.

Trans Condition										Home
	Turn	Lx	Lk	Cx	Zx	ACR	DCR	PS	BAL	Lk
Freq(Hz)	10.0000k	10.0000k	10.0000k	10.0000k	10.0000k	10.0000k				
Level	1 V	300mV	300mV	300mV	300mV	300mV	2 V	2 V		PRI.
Dev	OFF	Δ%	OFF	OFF	OFF	OFF	OFF			A1
Average	1	1	1	1	1	1	1	1		Clear Lk Table
Delay	0 s	0 s	0 s	0 s	0 s	0 s	0 s	0 s		Copy ↓ ↓
Equ		Series	Series	Parallel		Series				
Sequence	1	2	3	4	5	6	7	8	9	
Switch	ON	ON	ON	ON	ON	ON	ON	ON	ON	

Lk	Pins	Std(H)	Low	High	Freq(Hz)	Level	Short Pins
0	P01-P02	10.000μ	0.0010μ	12.000μ			
1	P11-P12						
2	P21-P22						
3	P31-P32						
4	P11-P22						
5	P11-P12						
6							
7							
8							
9							

#### 7.11.4.1 Lk Limit Setup

The Lk limit setting table is used to configure the Lk standard value, upper and lower limits, multi-frequency, multi-level, and short-circuit pins of each winding of the transformer.

Touch the Lk limit setting table, or move the cursor to the Lk limit setting area, and use the number keys, the corresponding magnification and the [ENTER] key to configure.

The magnification options corresponding to Lk are p, n, μ, m, and the [ENTER] key is x1.

Trans Condition										Home
	Turn	Lx	Lk	Cx	Zx	ACR	DCR	PS	BAL	Lk
Freq(Hz)	10.0000k	10.0000k	10.0000k	10.0000k	10.0000k	10.0000k				
Level	1 V	300mV	300mV	300mV	300mV	300mV	2 V	2 V		PRI.
Dev	OFF	Δ%	OFF	OFF	OFF	OFF	OFF			A1
Average	1	1	1	1	1	1	1	1		Clear Lk Table
Delay	0 s	0 s	0 s	0 s	0 s	0 s	0 s	0 s		Copy ↓ ↓
Equ		Series	Series	Parallel		Series				
Sequence	1	2	3	4	5	6	7	8	9	
Switch	ON	ON	ON	ON	ON	ON	ON	ON	ON	

Lk	Pins	Std(H)	Low	High	Freq(Hz)	Level	Short Pins
0	P01-P02	10.000μ	0.0010μ	12.000μ			
1	P11-P12						
2	P21-P22						
3	P31-P32						
4	P11-P22						
5	P11-P12						
6							
7							
8							
9							

### 7.11.4.2 Lk Multi-Frequency Setup

If you need to use different frequencies to measure different Lk pins of the transformer, in the transformer Lk limit setting table, touch or move the cursor to the frequency area of Lk. After inputting the frequency in this area, the frequency here will be automatically used during the test. If the parameter is not configured, the frequency of Lk in the measurement conditions table will be used.

Trans Condition										Home
	Turn	Lx	Lk	Cx	Zx	ACR	DCR	PS	BAL	Lk
Freq(Hz)	10.0000k	10.0000k	10.0000k	10.0000k	10.0000k	10.0000k				
Level	1 V	300mV	300mV	300mV	300mV	300mV	2 V	2 V		PRI. A1
Dev	OFF	Δ%	OFF	OFF	OFF	OFF	OFF			Clear Lk Table
Average	1	1	1	1	1	1	1	1		Copy ↓ ↓
Delay	0 s	0 s	0 s	0 s	0 s	0 s	0 s	0 s		
Equ		Series	Series	Parallel		Series				
Sequence	1	2	3	4	5	6	7	8	9	
Switch	ON	ON	ON	ON	ON	ON	ON	ON	ON	

Lk	Pins	Std(H)	Low	High	Freq(Hz)	Level	Short Pins
0	P01-P02	10.000μ	0.0010μ	12.000μ	20.0000k		
1	P11-P12						
2	P21-P22	10.000μ	0.0010μ	12.000μ			
3	P31-P32						
4	P11-P22						
5	P11-P12						
6							
7							
8							
9							

### 7.11.4.3 Lk Multi-Level Setup

If you need to use different levels to measure different Lk pins of the transformer, in the transformer Lk limit setting table, touch or move the cursor to the Lk level area. After inputting the level in this area, the test will automatically use this. If the parameter is not configured, the level of Lk in the measurement conditions table will be used.

Trans Condition										Home
	Turn	Lx	Lk	Cx	Zx	ACR	DCR	PS	BAL	Lk
Freq(Hz)	10.0000k	10.0000k	10.0000k	10.0000k	10.0000k	10.0000k				
Level	1 V	300mV	300mV	300mV	300mV	300mV	2 V	2 V		PRI. A1
Dev	OFF	Δ%	OFF	OFF	OFF	OFF	OFF			Clear Lk Table
Average	1	1	1	1	1	1	1	1		Copy ↓ ↓
Delay	0 s	0 s	0 s	0 s	0 s	0 s	0 s	0 s		
Equ		Series	Series	Parallel		Series				
Sequence	1	2	3	4	5	6	7	8	9	
Switch	ON	ON	ON	ON	ON	ON	ON	ON	ON	

Lk	Pins	Std(H)	Low	High	Freq(Hz)	Level	Short Pins
0	P01-P02	10.000μ	0.0010μ	12.000μ	20.0000k		
1	P11-P12						
2	P21-P22	10.000μ	0.0010μ	12.000μ		500mV	
3	P31-P32						
4	P11-P22						
5	P11-P12						
6							
7							
8							
9							

### 7.11.4.4 Lk Turn Ratio Short Pins

When setting the leakage inductance short pins, you can use the soft keys . and ~ to input multiple pins; the maximum number of pins can be saved here is 48.

**Example:**

- 1) Input a discontinuous number "1, 3, 5, 7, 9" and use the soft key . to separate each number; press [ENTER] to confirm. The final data displayed in the table is (1, 3, 5, 7, 9).
- 2) Input a continuous number of "1, 2, 3, 4, 5, 6, 7, 8, 9": first input the number "1", then press the soft key ~ , finally input "9". Press the [ENTER] key to confirm. The final data displayed in the table is (1 ~ 9).

**Note:** The maximum supported number of leakage inductance short pins is 48, and excess pins will be ignored.

- 3) Input part of continuous numbers and non-continuous numbers "1, 2, 3, 4, 5, 7, 9" (the continuous part is the same as step 2, the discontinuous part is the same as step 1); press [ENTER] to confirm. The final data displayed in the table is (1 ~ 5, 7, 9).

Trans Condition										↑
	Turn	Lx	Lk	Cx	Zx	ACR	DCR	PS	BAL	
Freq(Hz)	10.0000k	10.0000k	10.0000k	10.0000k	10.0000k	10.0000k				Lk
Level	1 V	300mV	300mV	300mV	300mV	300mV	2 V	2 V		PRI. ↻
Dev	OFF	Δ%	OFF	OFF	OFF	OFF	OFF			A1
Average	1	1	1	1	1	1	1	1		Clear Lk Table
Delay	0 s	0 s	0 s	0 s	0 s	0 s	0 s	0 s		Copy ↓ ↓
Equ		Series	Series	Parallel		Series				
Sequence	1	2	3	4	5	6	7	8	9	
Switch	ON	ON	ON	ON	ON	ON	ON	ON	ON	

Lk	Pins	Std(H)	Low	High	Freq(Hz)	Level	Short Pins
0	P01-P02	10.000μ	0.0010μ	12.000μ	20.0000k		P11~P12
1	P11-P12						
2	P21-P22	10.000μ	0.0010μ	12.000μ		500mV	P01~P12,P32~P31
3	P31-P32						
4	P11-P22						
5	P11-P12						
6							
7							
8							
9							

### 7.11.5 Cx Measurement Conditions Setup

On the <Trans Condition> page, touch or move the cursor to the Cx column of the test condition table to set the Cx parameters.

Trans Condition										↑
	Turn	Lx	Lk	Cx	Zx	ACR	DCR	PS	BAL	
Freq(Hz)	10.0000k	10.0000k	10.0000k	10.0000k	10.0000k	10.0000k				Cx
Level	1 V	300mV	300mV	300mV	300mV	300mV	2 V	2 V		PRI. ↻
Dev	OFF	Δ%	OFF	OFF	OFF	OFF	OFF			A1
Average	1	1	1	1	1	1	1	1		
Delay	0 s	0 s	0 s	0 s	0 s	0 s	0 s	0 s		
Equ		Series	Series	Parallel		Series				
Sequence	1	2	3	4	5	6	7	8	9	
Switch	ON	ON	ON	ON	ON	ON	ON	ON	ON	

Cx	Pins(+)	Pins(-)	Short Pins	Std(F)	Low	High	Freq(Hz)
0							
1							
2							
3							
4							
5							
6							
7							
8							
9							

### 7.11.5.1 Cx Limit Setup

The following figure shows the example transformer and the set-up screen to test the capacitance between two turns: Np1 and Np2.

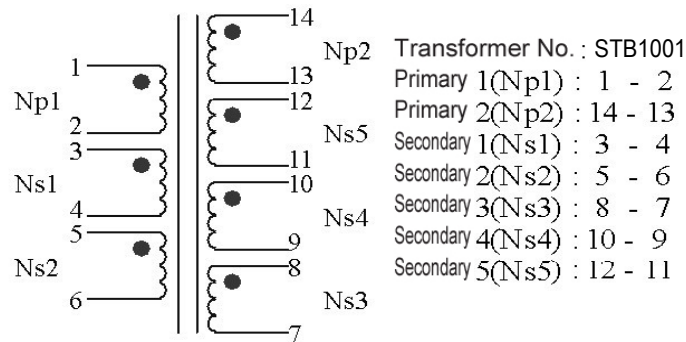

The Cx limit setting table is used to configure the positive and negative pins of Cx, short pins, nominal value, upper and lower limit, multi-frequency, multi-level, and D value limit.

Due to the large number of table parameters, one page cannot display all the setting parameters. Here, you can move the cursor left and right, or directly swipe the limit setting table on the screen to display the incomplete parameter settings.

Touch the Cx limit setting table, or move the cursor to the Cx limit setting area, and use the numeric keys, corresponding magnification and the [ENTER] key to configure.

The magnification options corresponding to Cx are p, n, μ, m, and the [ENTER] key is x1.

Trans Condition									
	Turn	Lx	Lk	Cx	Zx	ACR	DCR	PS	BAL
Freq(Hz)	10.0000k	10.0000k	10.0000k	10.0000k	10.0000k	10.0000k			
Level	1 V	300mV	300mV	300mV	300mV	300mV	2 V	2 V	
Dev	OFF	Δ%	OFF	OFF	OFF	OFF	OFF		
Average	1	1	1	1	1	1	1	1	
Delay	0 s	0 s	0 s	0 s	0 s	0 s	0 s	0 s	
Equ		Series	Series	Parallel		Series			
Sequence	1	2	3	4	5	6	7	8	9
Switch	ON	ON	ON	ON	ON	ON	ON	ON	ON

Cx	Short Pins	Std(F)	Low	High	Freq(Hz)	Level	D-Std	D-Low	D-High
0		10.000p	8.0000p	12.000p					
1									
2									
3									
4									
5									
6									
7									
8									
9									

### 7.11.5.2 Cx Pin(+), Pin(-) and Short Pins

When setting the Cx short pins, you can use the soft key . and ~ to input multiple pins. The maximum number of pins that can be saved here is 24.

**Example:**

- 1) Input a segment of discontinuous numbers "1, 3, 5, 7, 9", use the soft key . to separate each number; press the [ENTER] key to confirm. The final data displayed in the table is (1, 3, 5, 7, 9).
- 2) Input a continuous number of "1, 2, 3, 4, 5, 6, 7, 8, 9": first input the number "1", then press the soft key ~ , and finally input "9". Press the [ENTER] key to confirm. The final data displayed in the table is (1 ~ 9).

**Note:** The maximum number of Cx pins and short pins supported is 24; excess pins will be ignored.



- Input part of consecutive numbers and non-consecutive numbers "1, 2, 3, 4, 5, 7, 9" (the continuous part is the same as step 2, the non-consecutive part is the same as step 1); press the [ENTER] key to confirm. The final data displayed in the table is (1 ~ 5, 7, 9).

Trans Condition									
	Turn	Lx	Lk	Cx	Zx	ACR	DCR	PS	BAL
Freq(Hz)	10.0000k	10.0000k	10.0000k	10.0000k	10.0000k	10.0000k			
Level	1 V	300mV	300mV	300mV	300mV	300mV	2 V	2 V	
Dev	OFF	Δ%	OFF	OFF	OFF	OFF	OFF		
Average	1	1	1	1	1	1	1	1	
Delay	0 s	0 s	0 s	0 s	0 s	0 s	0 s	0 s	
Equ		Series	Series	Parallel		Series			
Sequence	1	2	3	4	5	6	7	8	9
Switch	ON	ON	ON	ON	ON	ON	ON	ON	ON

Cx	Pins(+)	Pins(-)	Short Pins	Std(F)	Low	High	Freq(Hz)
0	P01~P02	P62~P61		10.000p	8.0000p	12.000p	
1							
2							
3							
4							
5							
6							
7							
8							
9							

### 7.11.5.3 Cx Multi-Frequency Setup

If you need to use different frequencies to measure different Cx pins of the transformer, in the transformer Cx limit setting table, touch or move the cursor to the frequency area of Cx. After inputting the frequency in this area, the frequency here will be used automatically during the test. If the parameter is not configured, the frequency of Cx in the measurement conditions table will be used.

Trans Condition									
	Turn	Lx	Lk	Cx	Zx	ACR	DCR	PS	BAL
Freq(Hz)	10.0000k	10.0000k	10.0000k	10.0000k	10.0000k	10.0000k			
Level	1 V	300mV	300mV	300mV	300mV	300mV	2 V	2 V	
Dev	OFF	Δ%	OFF	OFF	OFF	OFF	OFF		
Average	1	1	1	1	1	1	1	1	
Delay	0 s	0 s	0 s	0 s	0 s	0 s	0 s	0 s	
Equ		Series	Series	Parallel		Series			
Sequence	1	2	3	4	5	6	7	8	9
Switch	ON	ON	ON	ON	ON	ON	ON	ON	ON

Cx	Pins(+)	Pins(-)	Short Pins	Std(F)	Low	High	Freq(Hz)
0	P01~P02	P62~P61		10.000p	8.0000p	12.000p	
1	P11~P12	P52~P51		10.000p	8.0000p	12.000p	12.000k
2							
3							
4							
5							
6							
7							
8							
9							

### 7.11.5.4 Cx Multi-Level Setup

If you need to use different levels to measure different Cx pins of the transformer, in the transformer Cx limit setting table, touch or move the cursor to the level area of Cx. After inputting the level in this area, it will be used automatically during the test. If the parameter is not configured, the level of Cx in the measurement conditions table will be used.

Trans Condition										Home
	Turn	Lx	Lk	Cx	Zx	ACR	DCR	PS	BAL	
Freq(Hz)	10.0000k	10.0000k	10.0000k	10.0000k	10.0000k	10.0000k				
Level	1 V	300mV	300mV	300mV	300mV	300mV	2 V	2 V		
Dev	OFF	Δ%	OFF	OFF	OFF	OFF	OFF			
Average	1	1	1	1	1	1	1	1		
Delay	0 s	0 s	0 s	0 s	0 s	0 s	0 s	0 s		
Equ		Series	Series	Parallel		Series				
Sequence	1	2	3	4	5	6	7	8	9	
Switch	ON	ON	ON	ON	ON	ON	ON	ON	ON	

Cx	Short Pins	Std(F)	Low	High	Freq(Hz)	Level	D-Std	D-Low	D-High
0		10.000p	8.0000p	12.000p					
1		10.000p	8.0000p	12.000p	12.0000k	500mV			
2									
3									
4									
5									
6									
7									
8									
9									

### 7.11.5.5 D Limit Setup

In the transformer Cx limit setting table, touch or move the cursor to D-Std, D-Low and D-High of Cx to configure.

**Note:** The D value test switch is set at the Cx switch.

Trans Condition										Home
	Turn	Lx	Lk	Cx	Zx	ACR	DCR	PS	BAL	
Freq(Hz)	10.0000k	10.0000k	10.0000k	10.0000k	10.0000k	10.0000k				
Level	1 V	300mV	300mV	300mV	300mV	300mV	2 V	2 V		
Dev	OFF	Δ%	OFF	OFF	OFF	OFF	OFF			
Average	1	1	1	1	1	1	1	1		
Delay	0 s	0 s	0 s	0 s	0 s	0 s	0 s	0 s		
Equ		Series	Series	Parallel		Series				
Sequence	1	2	3	4	5	6	7	8	9	
Switch	ON	ON	ON	ON	ON	ON	ON	ON	ON	

Cx	Short Pins	Std(F)	Low	High	Freq(Hz)	Level	D-Std	D-Low	D-High
0		10.000p	8.0000p	12.000p					
1		10.000p	8.0000p	12.000p	12.0000k	500mV	2.0000m		5.0000m
2									
3									
4									
5									
6									
7									
8									
9									

### 7.11.6 Zx Measurement Conditions Setup

On the <Trans Condition> page of the transformer scan, touch or move the cursor to a column of Zx in the measurement conditions to configure the Zx parameters.

Trans Condition										Zx
	Turn	Lx	Lk	Cx	Zx	ACR	DCR	PS	BAL	
Freq(Hz)	10.0000k	10.0000k	10.0000k	10.0000k	10.0000k	10.0000k				
Level	1 V	300mV	300mV	300mV	300mV	300mV	2 V	2 V		
Dev	OFF	Δ%	OFF	OFF	OFF	OFF	OFF	OFF		
Average	1	1	1	1	1	1	1	1		
Delay	0 s	0 s	0 s	0 s	0 s	0 s	0 s	0 s		
Equ		Series	Series	Parallel		Series				
Sequence	1	2	3	4	5	6	7	8	9	
Switch	ON	ON	ON	ON	ON	ON	ON	ON	ON	

Zx	Pins	Std(Ω)	Low	High	Bias	Freq(Hz)	Level	Short Pins
0	P01-P02							
1	P11-P12							
2	P21-P22							
3	P31-P32							
4	P11-P22							
5	P11-P12							
6								
7								
8								
9								

#### 7.11.6.1 Zx Limit Setup

The Zx limit setting table is used to configure the Zx standard value, upper and lower limit, bias, multi-frequency and multi-level.

Touch the Zx limit setting table, or move the cursor to the Zx limit setting area, and use the numeric keys, corresponding magnification and the [ENTER] key to configure.

The magnification options corresponding to Zx are M, k, μ, m, and the [ENTER] key is x1.

Trans Condition										Zx
	Turn	Lx	Lk	Cx	Zx	ACR	DCR	PS	BAL	
Freq(Hz)	10.0000k	10.0000k	10.0000k	10.0000k	10.0000k	10.0000k				
Level	1 V	300mV	300mV	300mV	300mV	300mV	2 V	2 V		
Dev	OFF	Δ%	OFF	OFF	OFF	OFF	OFF	OFF		
Average	1	1	1	1	1	1	1	1		
Delay	0 s	0 s	0 s	0 s	0 s	0 s	0 s	0 s		
Equ		Series	Series	Parallel		Series				
Sequence	1	2	3	4	5	6	7	8	9	
Switch	ON	ON	ON	ON	ON	ON	ON	ON	ON	

Zx	Pins	Std(Ω)	Low	High	Bias	Freq(Hz)	Level	Short Pins
0	P01-P02	628.00	600.00	800.00				
1	P11-P12							
2	P21-P22							
3	P31-P32							
4	P11-P22							
5	P11-P12	300.00	280.00	320.00				
6								
7								
8								
9								

### 7.11.6.2 Add DC Bias to Zx

The instrument can use a built-in DC bias current source of 100 mA or 2 A. When setting the current value, you can set a maximum value of 2 A for the sake of compatibility with the storage file.

Trans Condition										Zx
	Turn	Lx	Lk	Cx	Zx	ACR	DCR	PS	BAL	
Freq(Hz)	10.0000k	10.0000k	10.0000k	10.0000k	10.0000k	10.0000k				
Level	1 V	300mV	300mV	300mV	300mV	300mV	2 V	2 V		
Dev	OFF	Δ%	OFF	OFF	OFF	OFF	OFF			
Average	1	1	1	1	1	1	1	1		
Delay	0 s	0 s	0 s	0 s	0 s	0 s	0 s	0 s		
Equ		Series	Series	Parallel		Series				
Sequence	1	2	3	4	5	6	7	8	9	
Switch	ON	ON	ON	ON	ON	ON	ON	ON	ON	

Zx	Pins	Std(Ω)	Low	High	Bias	Freq(Hz)	Level	Short Pins
0	P01-P02	628.00	600.00	800.00	8mA			
1	P11-P12							
2	P21-P22							
3	P31-P32							
4	P11-P22							
5	P11-P12	300.00	280.00	320.00				
6								
7								
8								
9								

### 7.11.6.3 Zx Multi-Frequency Setup

If you need to use different frequencies to measure different Zx pins of the transformer, in the transformer Zx limit setting table, touch or move the cursor to the frequency area of Zx. After inputting the frequency in this area, the frequency here will be used automatically during the test. If the parameter is not configured, the frequency of Zx in the measurement conditions table will be used.

Trans Condition										Zx
	Turn	Lx	Lk	Cx	Zx	ACR	DCR	PS	BAL	
Freq(Hz)	10.0000k	10.0000k	10.0000k	10.0000k	10.0000k	10.0000k				
Level	1 V	300mV	300mV	300mV	300mV	300mV	2 V	2 V		
Dev	OFF	Δ%	OFF	OFF	OFF	OFF	OFF			
Average	1	1	1	1	1	1	1	1		
Delay	0 s	0 s	0 s	0 s	0 s	0 s	0 s	0 s		
Equ		Series	Series	Parallel		Series				
Sequence	1	2	3	4	5	6	7	8	9	
Switch	ON	ON	ON	ON	ON	ON	ON	ON	ON	

Zx	Pins	Std(Ω)	Low	High	Bias	Freq(Hz)	Level	Short Pins
0	P01-P02	628.00	600.00	800.00	8mA			
1	P11-P12							
2	P21-P22							
3	P31-P32							
4	P11-P22							
5	P11-P12	300.00	280.00	320.00		5.00000k		
6								
7								
8								
9								

### 7.11.6.4 Zx Multi-Level Setup

If you need to use different levels to measure different Zx pins of the transformer, in the transformer Zx limit setting table, touch or move the cursor to the level area of Zx. After inputting the level in this area, it will be used automatically during the test. If the parameter is not configured, the level of Zx in the measurement conditions table will be used.

Trans Condition										Zx
Freq(Hz)	Turn	Lx	Lk	Cx	Zx	ACR	DCR	PS	BAL	
10.0000k	10.0000k	10.0000k	10.0000k	10.0000k	10.0000k	10.0000k				
Level	1 V	300mV	300mV	300mV	300mV	300mV	2 V	2 V		
Dev	OFF	Δ%	OFF	OFF	OFF	OFF	OFF			
Average	1	1	1	1	1	1	1	1		
Delay	0 s	0 s	0 s	0 s	0 s	0 s	0 s	0 s		
Equ		Series	Series	Parallel		Series				
Sequence	1	2	3	4	5	6	7	8	9	
Switch	ON	ON	ON	ON	ON	ON	ON	ON	ON	

Zx	Pins	Std(Ω)	Low	High	Bias	Freq(Hz)	Level	Short Pins
0	P01-P02	628.00	600.00	800.00	8mA			
1	P11-P12							
2	P21-P22							
3	P31-P32							
4	P11-P22							
5	P11-P12	300.00	280.00	320.00		5.0000k	500mV	
6								
7								
8								
9								

### 7.11.7 ACR Measurement Conditions Setup

On the <Trans Condition> page of the transformer scan, touch or move the cursor to a column of ACR in the test condition table to set the ACR parameters.

Trans Condition										ACR
Freq(Hz)	Turn	Lx	Lk	Cx	Zx	ACR	DCR	PS	BAL	
10.0000k	10.0000k	10.0000k	10.0000k	10.0000k	10.0000k	10.0000k				
Level	1 V	300mV	300mV	300mV	300mV	300mV	2 V	2 V		
Dev	OFF	Δ%	OFF	OFF	OFF	OFF	OFF			
Average	1	1	1	1	1	1	1	1		
Delay	0 s	0 s	0 s	0 s	0 s	0 s	0 s	0 s		
Equ		Series	Series	Parallel		Series				
Sequence	1	2	3	4	5	6	7	8	9	
Switch	ON	ON	ON	ON	ON	ON	ON	ON	ON	

ACR	Pins	Std(Ω)	Low	High	Freq(Hz)	Level
0	P01-P02					
1	P11-P12					
2	P21-P22					
3	P31-P32					
4	P11-P22					
5	P11-P12					
6						
7						
8						
9						

### 7.11.7.1 ACR Limit Setup

The ACR limit setting table is used to configure the standard value, upper and lower limit, multi-frequency and multi-level of ACR.

Touch the ACR limit setting table, or move the cursor to the ACR limit setting area, and use the numeric keys, corresponding magnification and the [ENTER] key to set.

The magnification options corresponding to ACR are M, k,  $\mu$ , m, and the [ENTER] key is x1.

Trans Condition										ACR
Freq(Hz)	10.0000k	10.0000k	10.0000k	10.0000k	10.0000k	10.0000k				
Level	1 V	300mV	300mV	300mV	300mV	300mV	2 V	2 V		
Dev	OFF	$\Delta\%$	OFF	OFF	OFF	OFF	OFF			
Average	1	1	1	1	1	1	1	1		
Delay	0 s	0 s	0 s	0 s	0 s	0 s	0 s	0 s		
Equ		Series	Series	Parallel		Series				
Sequence	1	2	3	4	5	6	7	8	9	
Switch	ON	ON	ON	ON	ON	ON	ON	ON	ON	
ACR	Pins	Std( $\Omega$ )	Low	High	Freq(Hz)	Level				
0	P01-P02	11.000	10.000	12.000						
1	P11-P12									
2	P21-P22									
3	P31-P32									
4	P11-P22									
5	P11-P12	6.0000	5.0000	10.000						
6										
7										
8										
9										

### 7.11.7.2 ACR Multi-Frequency Setup

If you need to use different frequencies to measure different ACR pins of the transformer, in the transformer ACR limit setting table, touch or move the cursor to the frequency area of ACR. After inputting the frequency in this area, the frequency here will be used automatically during the test. If the parameter is not configured, the ACR frequency in the measurement conditions table will be used.

Trans Condition										ACR
Freq(Hz)	10.0000k	10.0000k	10.0000k	10.0000k	10.0000k	10.0000k				
Level	1 V	300mV	300mV	300mV	300mV	300mV	2 V	2 V		
Dev	OFF	$\Delta\%$	OFF	OFF	OFF	OFF	OFF			
Average	1	1	1	1	1	1	1	1		
Delay	0 s	0 s	0 s	0 s	0 s	0 s	0 s	0 s		
Equ		Series	Series	Parallel		Series				
Sequence	1	2	3	4	5	6	7	8	9	
Switch	ON	ON	ON	ON	ON	ON	ON	ON	ON	
ACR	Pins	Std( $\Omega$ )	Low	High	Freq(Hz)	Level				
0	P01-P02	11.000	10.000	12.000						
1	P11-P12									
2	P21-P22									
3	P31-P32									
4	P11-P22									
5	P11-P12	6.0000	5.0000	10.000	5.0000k					
6										
7										
8										
9										

### 7.11.7.3 ACR Multi-Level Setup

If you need to use different levels to measure different ACR pins of the transformer, in the transformer ACR limit setting table, touch or move the cursor to the ACR level area. After inputting the level in this area, it will be used automatically during the test. If the parameter is not configured, the ACR level in the measurement conditions table will be used.

Trans Condition										ACR	
Freq(Hz)	10.0000k	10.0000k	10.0000k	10.0000k	10.0000k	10.0000k	10.0000k				PRI.
Level	1 V	300mV	300mV	300mV	300mV	300mV	2 V	2 V			A1
Dev	OFF	Δ%	OFF	OFF	OFF	OFF	OFF				
Average	1	1	1	1	1	1	1	1			
Delay	0 s	0 s	0 s	0 s	0 s	0 s	0 s	0 s			
Equ		Series	Series	Parallel		Series					
Sequence	1	2	3	4	5	6	7	8	9		
Switch	ON	ON	ON	ON	ON	ON	ON	ON	ON		

ACR	Pins	Std(Ω)	Low	High	Freq(Hz)	Level
0	P01-P02	11.000	10.000	12.000		
1	P11-P12					
2	P21-P22					
3	P31-P32					
4	P11-P22					
5	P11-P12	6.0000	5.0000	10.000	5.0000k	500mV
6						
7						
8						
9						

### 7.11.8 DCR Measurement Conditions Setup

On the <Trans Condition> page of the transformer scan, touch or move the cursor to a column of DCR in the test condition table to set DCR parameters.

Trans Condition										DCR	
Freq(Hz)	10.0000k	10.0000k	10.0000k	10.0000k	10.0000k	10.0000k					PRI.
Level	1 V	300mV	300mV	300mV	300mV	300mV	2 V	2 V			A1
Dev	OFF	Δ%	OFF	OFF	OFF	OFF	OFF				
Average	1	1	1	1	1	1	1	1			
Delay	0 s	0 s	0 s	0 s	0 s	0 s	0 s	0 s			
Equ		Series	Series	Parallel		Series					
Sequence	1	2	3	4	5	6	7	8	9		
Switch	ON	ON	ON	ON	ON	ON	ON	ON	ON		

Dcr	Pins	Std(Ω)	Low	High
0	P01-P02			
1	P11-P12			
2	P21-P22			
3	P31-P32			
4	P11-P22			
5	P11-P12			
6				
7				
8				
9				

### 7.11.8.1 DCR Limit Setup

The DCR limit setting table is used to configure the standard value, upper and lower limit of DCR.

Touch the DCR limit setting table, or move the cursor to the DCR limit setting area, and use the numeric keys, corresponding magnification and the [ENTER] key to set.

The magnification options corresponding to DCR are M, k,  $\mu$ , m, and the [ENTER] key is x1.

Trans Condition										DCR	
Freq(Hz)	10.0000k	10.0000k	10.0000k	10.0000k	10.0000k	10.0000k	10.0000k	DCR	PS	BAL	
Level	1 V	300mV	300mV	300mV	300mV	300mV	300mV	2 V	2 V		
Dev	OFF	$\Delta\%$	OFF	OFF	OFF	OFF	OFF	OFF			
Average	1	1	1	1	1	1	1	1	1		
Delay	0 s	0 s	0 s	0 s	0 s	0 s	0 s	0 s	0 s		
Equ		Series	Series	Parallel		Series					
Sequence	1	2	3	4	5	6	7	8	9		
Switch	ON	ON	ON	ON	ON	ON	ON	ON	ON	ON	

Dcr	Pins	Std( $\Omega$ )	Low	High
0	P01-P02	250.00m	240.00m	260.00m
1	P11-P12	110.00m	100.00m	130.00m
2	P21-P22	110.00m	100.00m	130.00m
3	P31-P32	81.00m	70.00m	90.00m
4	P11-P22			
5	P11-P12			
6				
7				
8				
9				

### 7.11.9 PS Measurement Conditions Setup

On the <Trans Condition> page of the transformer scan, touch or move the cursor to a column of PS in the test condition table to set PS parameters.

Trans Condition										PS	
Freq(Hz)	10.0000k	10.0000k	10.0000k	10.0000k	10.0000k	10.0000k	10.0000k	DCR	PS	BAL	
Level	1 V	300mV	300mV	300mV	300mV	300mV	300mV	2 V	2 V		
Dev	OFF	$\Delta\%$	OFF	OFF	OFF	OFF	OFF	OFF			
Average	1	1	1	1	1	1	1	1	1		
Delay	0 s	0 s	0 s	0 s	0 s	0 s	0 s	0 s	0 s		
Equ		Series	Series	Parallel		Series					
Sequence	1	2	3	4	5	6	7	8	9		
Switch	ON	ON	ON	ON	ON	ON	ON	ON	ON	ON	

PS	PS +	PS -	Low	High
0			10.000k	
1			10.000k	
2			10.000k	
3			10.000k	
4			10.000k	
5			10.000k	
6			10.000k	
7			10.000k	
8			10.000k	
9			10.000k	

#### 7.11.9.1 PS Limit Setup

The PS limit setting table is used to configure the positive and negative pins and upper and lower limits of PS.

Touch the PS limit setting table, or move the cursor to the PS limit setting area, and use the numeric keys, corresponding magnification and the [ENTER] key to set.

The magnification options corresponding to PS are M, k,  $\mu$ , m, and the [ENTER] key is x1.

The default lower limit of PS is 10 k $\Omega$ .



**Note:** In general testing, the upper limit does not need to be set; that is, there is no upper limit.

Trans Condition										PS
	Turn	Lx	Lk	Cx	Zx	ACR	DCR	PS	BAL	
Freq(Hz)	10.0000k	10.0000k	10.0000k	10.0000k	10.0000k	10.0000k				
Level	1 V	300mV	300mV	300mV	300mV	300mV	2 V	2 V		
Dev	OFF	Δ%	OFF	OFF	OFF	OFF	OFF			
Average	1	1	1	1	1	1	1	1		
Delay	0 s	0 s	0 s	0 s	0 s	0 s	0 s	0 s		
Equ		Series	Series	Parallel		Series				
Sequence	1	2	3	4	5	6	7	8	9	
Switch	ON	ON	ON	ON	ON	ON	ON	ON	ON	

  

PS	PS +	PS -	Low	High
0			10.000k	
1			10.000k	
2			10.000k	
3			10.000k	
4			10.000k	
5			10.000k	
6			10.000k	
7			10.000k	
8			10.000k	
9			10.000k	

### 7.11.9.2 PS Test Pin Setup

This page is used to set the shorted pins. In the process of auto scanning test, the instrument will test DCR of each set pin and make comparison with the PS low limit set on PS limit setup page.

The following figure shows the example transformer and its setup page of pin short test.

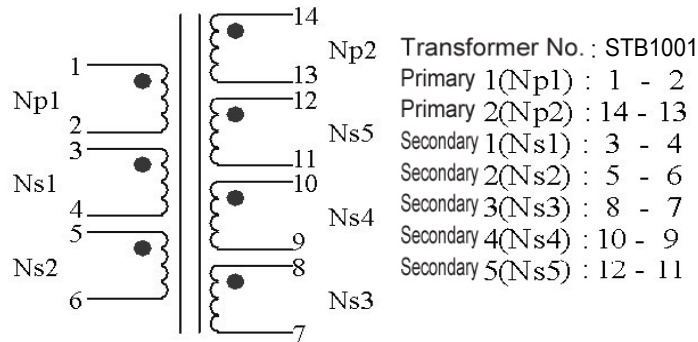

When setting the positive and negative pins of PS, you can use the soft key . and ~ to input multiple pins, where a maximum of 12 pins can be saved.

**Example:**

- 1) Input a segment of discontinuous numbers "1, 3, 5, 7, 9"; use the soft key . to separate each number and press the [ENTER] key to confirm. The final data displayed in the table is (1, 3, 5, 7, 9).
- 2) Input a continuous number "1, 2, 3, 4, 5, 6, 7, 8, 9": first input the number "1", then press the soft key ~ , and finally input "9". Press the [ENTER] key to confirm. The final data displayed in the table is (1 ~ 9).

**Note:** The maximum number of PS positive and negative pins supported is 12, and excess pins will be ignored.

- 3) Input part of continuous numbers and non-consecutive numbers "1, 2, 3, 4, 5, 7, 9" (the continuous part is the same as step 2, the non-continuous part is the same as step 1); press the [ENTER] key to confirm. The final data displayed in the table is (1 ~ 5, 7, 9).

Trans Condition										PS
	Turn	Lx	Lk	Cx	Zx	ACR	DCR	PS	BAL	
Freq(Hz)	10.0000k	10.0000k	10.0000k	10.0000k	10.0000k	10.0000k				
Level	1 V	300mV	300mV	300mV	300mV	300mV	2 V	2 V		
Dev	OFF	Δ%	OFF	OFF	OFF	OFF	OFF			
Average	1	1	1	1	1	1	1	1		
Delay	0 s	0 s	0 s	0 s	0 s	0 s	0 s	0 s		
Equ		Series	Series	Parallel		Series				
Sequence	1	2	3	4	5	6	7	8	9	
Switch	ON	ON	ON	ON	ON	ON	ON	ON	ON	

PS	PS +	PS -	Low	High
0	P02	P11	10.000k	
1	P12	P21	10.000k	
2	P31	P42	10.000k	
3	P41	P52	10.000k	
4	P51	P62	10.000k	
5	P01~P02	P52~P51	10.000k	
6			10.000k	
7			10.000k	
8			10.000k	
9			10.000k	

### 7.11.10 BAL Measurement Conditions Setup

On the <Trans Condition> page of the transformer scan, touch or move the cursor to a column of BAL in the test condition table to set BAL parameters.

Trans Condition										BAL
	Turn	Lx	Lk	Cx	Zx	ACR	DCR	PS	BAL	
Freq(Hz)	10.0000k	10.0000k	10.0000k	10.0000k	10.0000k	10.0000k				
Level	1 V	300mV	300mV	300mV	300mV	300mV	2 V	2 V		
Dev	OFF	Δ%	OFF	OFF	OFF	OFF	OFF			
Average	1	1	1	1	1	1	1	1		
Delay	0 s	0 s	0 s	0 s	0 s	0 s	0 s	0 s		
Equ		Series	Series	Parallel		Series				
Sequence	1	2	3	4	5	6	7	8	9	
Switch	ON	ON	ON	ON	ON	ON	ON	ON	ON	

BAL	B1	B2	Abs	Formula	Std	Low	High
0			ON	Lx1-Lx2			
1			ON	Lx1-Lx2			
2			ON	Lx1-Lx2			
3			ON	Lx1-Lx2			
4			ON	Lx1-Lx2			
5			ON	Lx1-Lx2			
6			ON	Lx1-Lx2			
7			ON	Lx1-Lx2			
8			ON	Lx1-Lx2			
9			ON	Lx1-Lx2			

#### 7.11.10.1 BAL Measurement Setup

BAL (Balance) is a parameter used to compare the consistency of the two windings of a transformer. BAL upper and lower limits, balance windings, absolute values, and balance formulas can be configured.

Touch the BAL table, or move the cursor to the BAL measurement settings area, and use the numeric keys, corresponding magnification and the [ENTER] key to set.

The magnification options corresponding to BAL are p, n, μ, m, and the [ENTER] key is x1.

Trans Condition										BAL
	Turn	Lx	Lk	Cx	Zx	ACR	DCR	PS	BAL	
Freq(Hz)	10.0000k	10.0000k	10.0000k	10.0000k	10.0000k	10.0000k				
Level	1 V	300mV	300mV	300mV	300mV	300mV	2 V	2 V		
Dev	OFF	Δ%	OFF	OFF	OFF	OFF	OFF			
Average	1	1	1	1	1	1	1	1		
Delay	0 s	0 s	0 s	0 s	0 s	0 s	0 s	0 s		
Equ		Series	Series	Parallel		Series				
Sequence	1	2	3	4	5	6	7	8	9	
Switch	ON	ON	ON	ON	ON	ON	ON	ON	ON	

BAL	B1	B2	Abs	Formula	Std	Low	High
0	P01-P02	P11-P12	ON	Lx1-Lx2			
1			ON	Lx1-Lx2			
2			ON	Lx1-Lx2			
3			ON	Lx1-Lx2			
4			ON	Lx1-Lx2			
5			ON	Lx1-Lx2			
6			ON	Lx1-Lx2			
7			ON	Lx1-Lx2			
8			ON	Lx1-Lx2			
9			ON	Lx1-Lx2			

### 7.11.10.2 BAL Absolute Value Setup

Use this setting to configure whether, in the equation used to judge the balance of the two windings, the final result is compared with the absolute value or not.

For example, for the equation  $Lx1-Lx2$ :

- When the absolute value setting is ON, the equation will be converted to  $|Lx1-Lx2|$ , and the result will be the absolute value of  $Lx1-Lx2$  compared with the set upper and lower limits.
- When the absolute value setting is OFF, the equation will remain  $Lx1-Lx2$ , the result will be directly compared with the upper and lower limits set, and the result can be positive or negative.

Trans Condition										BAL
	Turn	Lx	Lk	Cx	Zx	ACR	DCR	PS	BAL	
Freq(Hz)	10.0000k	10.0000k	10.0000k	10.0000k	10.0000k	10.0000k				
Level	1 V	300mV	300mV	300mV	300mV	300mV	2 V	2 V		
Dev	OFF	Δ%	OFF	OFF	OFF	OFF	OFF			
Average	1	1	1	1	1	1	1	1		
Delay	0 s	0 s	0 s	0 s	0 s	0 s	0 s	0 s		
Equ		Series	Series	Parallel		Series				
Sequence	1	2	3	4	5	6	7	8	9	
Switch	ON	ON	ON	ON	ON	ON	ON	ON	ON	

BAL	B1	B2	Abs	Formula	Std	Low	High
0	P01-P02	P11-P12	OFF	Lx1-Lx2			
1			ON	Lx1-Lx2			
2			ON	Lx1-Lx2			
3			ON	Lx1-Lx2			
4			ON	Lx1-Lx2			
5			ON	Lx1-Lx2			
6			ON	Lx1-Lx2			
7			ON	Lx1-Lx2			
8			ON	Lx1-Lx2			
9			ON	Lx1-Lx2			

### 7.11.10.3 BAL Equation Setup

Currently, there are 5 equations to choose from, which are as follows:

- $Lx1-Lx2$
- $DCR1-DCR2$
- $DCR1-DCR2$
- $DCR1-DCR2$
- $DCR1-DCR2$

When the absolute value switch is changed, it will affect the final result of this equation.

Trans Condition										Home
	Turn	Lx	Lk	Cx	Zx	ACR	DCR	PS	BAL	BAL
Freq(Hz)	10.0000k	10.0000k	10.0000k	10.0000k	10.0000k	10.0000k				
Level	1 V	300mV	300mV	300mV	300mV	300mV	2 V	2 V		Lx1-Lx2
Dev	OFF	Δ%	OFF	OFF	OFF	OFF	OFF			DCR1-DCR2
Average	1	1	1	1	1	1	1	1		Lk1-Lk2
Delay	0 s	0 s	0 s	0 s	0 s	0 s	0 s	0 s		Lk1/Lk2
Equ		Series	Series	Parallel		Series				Lx1/Lx2
Sequence	1	2	3	4	5	6	7	8	9	Return
Switch	ON	ON	ON	ON	ON	ON	ON	ON	ON	

BAL	B1	B2	Abs	Formula	Std	Low	High
0	P01-P02	P11-P12	OFF	Lx1-Lx2			
1			ON	Lx1-Lx2			
2			ON	Lx1-Lx2			
3			ON	Lx1-Lx2			
4			ON	Lx1-Lx2			
5			ON	Lx1-Lx2			
6			ON	Lx1-Lx2			
7			ON	Lx1-Lx2			
8			ON	Lx1-Lx2			
9			ON	Lx1-Lx2			

### 7.11.11 Handler Mode Function

After a scan test, the Handler outputs the final sorting signal according to the settings here.

There are currently three sorting modes:

- **Default:** Output unqualified signals according to the parameters shown in the signal column in the table.
- **X30:** According to the page in the table, a group of two pages will output the unqualified signal.
- **X12:** According to the page in the table, a group of five pages will output the unqualified signal.

Handler Mode										Home
Handler Mode	X30				Interface		Handler - 1			Handler Mode
Pin	Signal	Page	Direction	Function	Pin	Signal	Page	Direction	Function	Default
1	FAIL_01	A1-A2	Output		11,12,13	+5V	N/A	Output	I <sub>max</sub> =0.3A	X30
2	FAIL_02	A3-A4	Output		14,15,16,17	GND	N/A	Output	GND	X12
3	FAIL_03	A5-B1	Output		18	24V-	N/A	Output	Cylinder -	
4	FAIL_04	B2-B3	Output		19	EXT_GND	N/A	Input	GND_EXT	
5	FAIL_05	B4-B5	Output		20	24V+	N/A	Output	Cylinder +	
6	FAIL_06	C1-C2	Output		21	EXT_VCC	N/A	Input	3.3V ~ 24V	
7	FAIL_07	C3-C4	Output		22	EXT_RESET	N/A	Input		
8	FAIL_08	C5-D1	Output		23	EXT_START	N/A	Input		
9	FAIL_09	D2-D3	Output		24	FAIL_ANY	ALL	Output		
10	TEST	N/A	Output		25	PASS_ALL	ALL	Output		

### 7.11.12 Parameter Copy Function

After setting the setting parameters of the transformer A board, such as Pin-to-Fixture, Transformer Pins and measurement conditions, use the parameter copy function to automatically copy the parameters of the A board to the B ~ L boards. Doing so can save the time of repeatedly re-configuring the parameters of the B ~ L boards.

## 7.11.13 Statistics Page

On the transformer scan setting page, press the function key [Statistics], it will jump to the <Statistics> page.

Trans Stat				Trans Statistics
	Pass	Fail	SUM	
Turn				Trans ID
Lx				Pin To Fixture
Lk				Pin Setup
Cx				Condition
Zx				Copy
ACR				Handler Mode
DCR				Stat
PS				Tools
BAL				
Whole				

The page states the following:

- **[PASS]** indicates the pass times of each parameter of Lk ~ DCR.
- **[PASS]+[WHOLE]**: In one measurement, all parameters that need to be measured in Lk ~ DCR are qualified, then [PASS] corresponds to the value of [WHOLE] (total qualified column) plus 1.
- **[FAIL]** Indicates the fail times of each parameter of Lk ~ DCR.
- **[FAIL]+[WHOLE]**: In one measurement, if one or more parameters to be measured in Lk ~ DCR are unqualified, then [FAIL] corresponds to the value of [WHOLE] (total unqualified column) plus 1.
- **[SUM]** indicates the total measurement times of a measurement parameter;
- **[SUM]+[WHOLE]** indicates the total number of measurements, which is equal to the total number of pass times and the total number of fail times.

### 7.11.13.1 Resetting the Statistical Count

Click on the statistics table and the [Reset Count] function will appear in the menu area. Pressing the [Reset Count] function button will reset all data in the table on the <Scan Test Statistics> page to zero.

## 7.12 <Trans Scan>

After all settings are completed, directly press the [DISP] key to enter the <Trans Scan> page. Before starting the test, it is usually best to press the [FILE] key to enter the <File Management> page, and save the settings for future use. For details, see Chapter 4.2 <File>. After saving the file, enter the <Trans Scan> page.

If you are only using the internal scanning board, just press the [TRIGGER] key on the front panel to trigger the test. If you are using a scan box, make sure that the host and scan box are installed and connected correctly. Now you can place the transformer to be tested on the test fixture and press the [START] button on the scan box to start the scan. The test value will be displayed on the screen. If the test is defective, the test value is displayed in red. The instrument will display the scan data and the final PASS/FAIL according to the settings of the scan result display on the <Trans ID> page.

During scanning, if a particular pin of Lx or Zx is set to add DC bias current, the instrument will automatically add the corresponding DC bias current and light the [DC BIAS] button.

Trans Scan											I:\files\GuideBook.t40	Setup
A1	Pin	Turn-V	Lx(H)	Lk(H)	Cp(F)	Zx(Ω)	ACR(Ω)	DCR(Ω)	PS	Bala		
0	P01-P02	1.0000	-382.87μ	-9.6958	001 - 013	11.633k	1.3556M	-750.00m	002 - 003	001-002		
1	P11-P12	207.97m	553.68μ	-9.4669	003 - 011	1.6621M	1.3588M	-890.00m	004 - 005			
2	P21-P22	146.96m	1.2310m	-4.5691		1.3641M	1.5967M	110.00m	008 - 009			
3	P31-P32								010 - 011			
4	P11-P22								012 - 013			
5	P11-P12								001 - 011			
6												
7												
8												
9												
A2	Pin	Turn-V	Lx(H)	Lk(H)	Cp(F)	Zx(Ω)	ACR(Ω)	DCR(Ω)	PS	Bala		
0	P61-P62	1.0000	-308.00m	-3.9079		1.6634M	1.4570M	8.4071M				
1	P11-P12	208.45m	-1.6171	-3.4051		1.4998M	1.4758M	6.6955M				
2	P21-P22	143.30m	-3.5710	-2.8760		1.5548M	1.5063M	-1.0000				
3	P31-P32											
4	P41-P42											
5	P51-P52											
6												
7												
8												
9												

### 7.12.1 Each Display Zone under This Page

- **PIN Area:** The area below the column displays the pins of each winding, but the pins of Cx are not displayed in this area. If you need to check, you can press the [DISP] key, and the pins will be displayed in the cell of the measurement result (only the first of the positive and negative pins is displayed).
- **Each Parameter Measurement Result Display Area (Turn, Lx, Q, LK, Cx, D, ZX, ACR, DCR, PS, BAL):** When all parameters are turned on, you can press the left and right keys or touch left and right to slide to view the not all displayed parameter.

### 7.12.2 Function Keys on This Page

- **[TRIGGER]** is used to start the instrument for scan measuring.
- **[RESET]** is used to interrupt an ongoing scan test.
- **[KEYLOCK]** locks the keyboard. After locking the keyboard, the user can also perform other operations such as scan test, but the parameter settings cannot be modified. This function can be used to prevent testers from changing or deleting the set measurement conditions by mistake. Shut down after locking the keyboard, the current test file will be called automatically next time it is turned on. **[FILE]** is used to enter the file management page.
- **[CAL]** is used to turn on the open-circuit test fixture scanning correction function, as shown in the figure below:

Trans Scan											I:\files\GuideBook.t40	Cal
A1	Pin	Turn-V	Lx(H)	Lk(H)	Cp(F)	Zx(Ω)	ACR(Ω)	DCR(Ω)	PS	Bala		
0	P01-P02	1.0000	-382.87μ	-9.6958	001 - 013	11.633k	1.3556M	-750.00m	002 - 003	001-002		
1	P11-P12	207.97m	553.68μ	-9.4669	003 - 011	1.6621M	1.3588M	-890.00m	004 - 005			
2	P21-P22	146.96m	1.2310m	-4.5691		1.3641M	1.5967M	110.00m	008 - 009			
3	P31-P32								010 - 011			
4	P11-P22								012 - 013			
5	P11-P12								001 - 011			
6												
7												
8												
9												
A2	Pin	Turn-V	Lx(H)	Lk(H)	Cp(F)	Zx(Ω)	ACR(Ω)	DCR(Ω)	PS	Bala		
0	P61-P62	1.0000	-308.00m	-3.9079		1.6634M	1.4570M	8.4071M				
1	P11-P12	208.45m	-1.6171	-3.4051		1.4998M	1.4758M	6.6955M				
2	P21-P22	143.30m	-3.5710	-2.8760		1.5548M	1.5063M	-1.0000				
3	P31-P32											
4	P41-P42											
5	P51-P52											
6												
7												
8												
9												

At this time, put an open-circuit transformer sample with the same pin position as the product under test on the test fixture, and then press the soft key [Meas Open], and the instrument will perform an open-circuit correction on the test fixture. This function can improve the test accuracy of small inter-turn capacitance and large inductance (>300 mH level), and can also improve the open circuit value of DCR and PS.

High frequency open circuit can improve the test accuracy at high frequency.

**[CAL] Turn on the short-circuit test fixture scan correction function:**

At this time, put a short-circuit transformer sample with the same pin as the product under test on the test fixture, and then press the soft key [Meas Short], and the instrument will perform a short-circuit correction on the test fixture. This function can improve the test accuracy of small DC resistance and small inductance.

After the open and short-circuit correction, if you want to use the clear data in the test, you need to open the corresponding switch.

### 7.12.3 PRI Page-Turning Function

In the transformer scan measurement test interface, after measuring a transformer with multiple primary windings, you can switch the primary (PRI) page with the knob to view the measurement results, and the untested pages will be ignored directly.

Trans Scan										I:\files\GuideBook.t40	Home
A1	Pin	Lx(H)	Lk(H)	Cp(F)	Zx(Ω)	ACR(Ω)	DCR(Ω)	PS	Balance	Setup	
0	P01-P02	-382.87μ	-9.6958	001 - 013	11.633k	1.3556M	-750.00m	002 - 003	001-002:003-004	Pri.	
1	P11-P12	553.68μ	-9.4669	003 - 011	1.6621M	1.3588M	-890.00m	004 - 005		A1,A2	
2	P21-P22	1.2310m	-4.5691		1.3641M	1.5967M	110.00m	008 - 009		Load Std	
3	P31-P32							010 - 011		OFF	
4	P11-P22							012 - 013		Deviation	
5	P11-P12							001 - 011		OFF	
6										Speed	
7										Fast	
8										Test Fail	
9										Continue	
A2	Pin	Lx(H)	Lk(H)	Cp(F)	Zx(Ω)	ACR(Ω)	DCR(Ω)	PS	Balance		
0	P61-P62	-308.00m	-3.9079		1.6634M	1.4570M	8.4071M			Focus	
1	P11-P12	-1.6171	-3.4051		1.4998M	1.4758M	6.6955M			OFF	
2	P21-P22	-3.5710	-2.8760		1.5548M	1.5063M	-1.0000			Split	
3	P31-P32									2-1	
4	P41-P42									Save	
5	P51-P52									OFF	
6											
7											
8											
9											

Press the Knob key and the Primary (PRI) page will return to the A1 page.

### 7.12.4 Pin Display Function for Stray Capacitance

After measuring the stray capacitance, press the Display key to view some pins of the current stray capacitance.

Trans Scan										I:\files\GuideBook.t40	Home
A1	Pin	Lx(H)	Lk(H)	Cp(F)	Zx(Ω)	ACR(Ω)	DCR(Ω)	PS	Balance	Setup	
0	P01-P02	-382.87μ	-9.6958	001 - 013	11.633k	1.3556M	-750.00m	002 - 003	001-002,003-004	Pri.	
1	P11-P12	553.68μ	-9.4669	003 - 011	1.6621M	1.3588M	-890.00m	004 - 005		A1,A2	
2	P21-P22	1.2310m	-4.5691		1.3641M	1.5967M	110.00m	008 - 009		Load Std	
3	P31-P32							010 - 011		OFF	
4	P11-P22							012 - 013		Deviation	
5	P11-P12							001 - 011		OFF	
6										Speed	
7										Fast	
8										Test Fail	
9										Continue	
A2	Pin	Lx(H)	Lk(H)	Cp(F)	Zx(Ω)	ACR(Ω)	DCR(Ω)	PS	Balance	Focus	
0	P61-P62	-308.00m	-3.9079		1.6634M	1.4570M	8.4071M			OFF	
1	P11-P12	-1.6171	-3.4051		1.4998M	1.4758M	6.6955M			Split	
2	P21-P22	-3.5710	-2.8760		1.5548M	1.5063M	-1.0000			2-1	
3	P31-P32									Save	
4	P41-P42									OFF	
5	P51-P52										
6											
7											
8											
9											

### 7.12.5 BAL Balance Parameter Display

After the scan is over, press the [DISP] key to switch to display the result value between the two windings of the BAL.

## 7.13 <File> Page of Transformer Scan

File				Home
Name	Size	Date Modified		File
files		2021/12/13	10:56:58	Save .t40
PIC		2021/12/13	10:56:37	Copy to E:\
0000.t40	453 KB	2021/11/02	13:49:42	Rename
0001.t40	453 KB	2021/11/04	09:54:57	Delete
001.t40	453 KB	2021/11/12	14:13:06	New folder
1.t40	453 KB	2021/11/04	10:16:06	
0002.t40	453 KB	2021/11/04	15:28:19	
002.t40	453 KB	2021/11/17	10:57:07	
2.t40	453 KB	2021/11/04	10:17:14	
3.t40	453 KB	2021/12/13	10:56:58	
1831.t40	453 KB	2021/07/22	08:20:39	
1901.t40	453 KB	2021/07/22	08:20:37	
1111111.t40	453 KB	2021/08/03	11:21:17	
2220329-QA3PC.t40	453 KB	2021/11/05	14:13:38	
2250187-02FX-12B.t40	453 KB	2021/08/03	11:22:27	
2250187-02FX-12C.t40	453 KB	2021/09/10	16:11:16	
devT1.t40	453 KB	2021/09/27	10:56:39	
devT2.t40	453 KB	2021/09/27	10:57:56	
E-0409-H273.t40	439 KB	2021/07/22	08:20:34	
G7202DG.t40	453 KB	2021/07/22	08:20:31	
PinLabel.t40	453 KB	2021/10/12	15:25:27	
STATE.sta	24 KB	2021/08/13	22:17:25	
Int:128MB(210MB)    Ext:28GB(28GB)    Mem:105MB(247MB)				

### 7.13.1 Transformer Scan Setup File (\*.t40)

The internal space of the instrument can save a certain number of scan settings files (\*.t40 files); the number is determined by the remaining internal storage space. The scan settings files can also be displayed/operated through an external storage USB flash drive, and supports large-capacity USB flash drives (FAT32 format) read and write functions.



All setting data on the following pages will be saved or loaded in the form of files, called \*.t40 files.

- <Trans ID>
- <Trans Pin to Fixture>
- <Trans Pin Setup>
- <Trans Condition>
- <Trans Deviation>
- < Handler Mode>
- Some menu functions in <Trans Scan Test>

### 7.13.1.1 USB Drive Manage Performance

As mentioned above, the ST2840X is equipped with a USB HOST interface as standard, which can use an external USB flash drive as a storage medium, thus breaking through the storage limitation of the internal settings files of the instrument, and can also copy these files to an IBM PC with a USB interface or a compatible desktop, computer, notebook computer, so as to achieve unlimited expansion.

ST2840X supports the following USB mass storage devices (USB flash drives):

- Compliant with USB 2.0 standard
- Capacity: 2GB / 4GB / 8GB / 16GB / 32GB
- File format: FAT32 (formatted with Microsoft Windows operating system)

## 7.13.2 Operation Steps for File Management

### 7.13.2.1 View Existing Files

- 1) Click the [+] before the folder icon, or click the folder and right-click to view all the files in this folder.
- 2) Files saved in the root directory can be viewed directly by turning the knob counterclockwise. Follow the steps below to save control setup parameters to a file.
- 3) First set all the control parameters of the desired page.
- 4) Press the soft key [FILE] to enter the file management page.
- 5) When you move the cursor to any file or folder, the menu will display the following:
  - Save.t40
  - Copy to E:\
  - Rename
  - Delete
  - New folder
- 6) Select [Save.t40] to save the settings file.
- 7) After pressing the save soft key, the screen will display the soft keyboard.
- 8) Enter characters as the file name and press OK to save, press Esc to cancel saving the file.
  - When saving a file with the same file name, the "File Existing" dialog box will pop up. Select Overwrite to overwrite the file with the same name; select Rename to re-enter the file name; select Cancel to cancel the saving of this file.

- 9) Press the [DISP] key to enter the transformer scan test page.
- 10) Follow the steps below to load control setup parameters from a file.
- 11) Press the soft key [FILE] to enter the file management page.
- 12) Selecting the .t40 file you want to load will display the following menu:
  - Load
  - Save.40
  - Copy to E:
  - Rename
  - Delete
  - New folder
- 13) Press the [Load] soft key and the screen will display the following menu:
  - Load
  - Cancel
- 14) Pressing [Cancel] will cancel the current load operation and return to step 1.
- 15) Press [Load] and the currently selected file will be loaded. At the same time, you will enter the <Trans Scan> page.

### 7.13.3 Transformer Deviation-Deduction

If you have the standard samples of untested transformer, and its data of each test can serve as the measurement standard, the deviation-deduction function is available.

The operation of deviation function is listed below:

- 1) According to the set method, enter the <Trans Scan> page after setting parameter.
- 2) Put standard transformer to test fixture and lock it, press [START] in scan box several times to get a stable test value;
- 3) Press [Deviation] to enter the <Trans Deviation> page.

Trans Deviation										Dev value
Para	Turn	Lx	Q	Lk	Cx	D	Zx	ACR	DCR	
High(%)	300	300	300	3k	300	300	300	300	500	PRI.
Low(%)	-60	-60	-60	-90	-60	-60	-60	-60	-60	A1
Mode	OFF	DIV	OFF	OFF	OFF	OFF	OFF	OFF	SUB	Deviation
PRI.	P01-P02		1						1	OFF
SEC.1	P11-P12		1						1	Test & Load
SEC.2	P21-P22		1						1	Reset Column
SEC.3	P31-P32		1						1	Item
SEC.4	P11-P22		1							ON
SEC.5	P11-P12		1							Exit
SEC.6										
SEC.7										
SEC.8										
SEC.9										

- 4) Set [Deviation] to ON;
- 5) Set the correction parameter switch to DIV or SUB;

- 6) Set the high and low limits allowed for deduction of each parameter;
- 7) Press [Deviation] to perform the correction, and return to the <Trans Scan> page.
- 8) After the deduction is successful, if the user triggers the test again, the measured value displayed by the instrument will be the same as the value of the standard product.
- 9) If you need to check the deviation value used by each parameter at this time, just return to the <Trans Deviation> page to check.

Trans Deviation										Dev value
Para	Turn	Lx	Q	Lk	Cx	D	Zx	ACR	DCR	
High(%)	300	300	300	3k	300	300	300	300	500	PRI.
Low(%)	-60	-60	-60	-90	-60	-60	-60	-60	-60	A1
Mode	OFF	DIV	OFF	OFF	OFF	OFF	OFF	OFF	SUB	Deviation 21/12/16 14:56
PRI.	P01-P02	-2.169m								Test & Load
SEC.1	P11-P12	-97.391μ								Reset Column
SEC.2	P21-P22	-373.54μ								Item ON
SEC.3	P31-P32	1								Exit
SEC.4	P11-P22	1								
SEC.5	P11-P12	1								
SEC.6										
SEC.7										
SEC.8										
SEC.9										

**Note:** When modifying the DIV value, it can not be be revised as 0.

If you need to save the deduction value, press the soft key [FILE] to enter the file management page, and follow the on-screen prompts to save the file so that the same transformer can be measured after the next restart.

## 7.14 Focus

The focus function makes it easier to repeat the test between the specified windings or between the specified parameters.

On the <Trans Scan> page, turn on the [Focus] switch, and then click the parameter you want to test repeatedly.

Click on the cell; when its background turns blue, it is in the selected state. At this time, press the [TRIGGER] key to measure the data of this cell.

Trans Scan										I:\files\GuideBook.t40
A1	Pin	Lx(H)	Lk(H)	Cp(F)	Zx(Ω)	ACR(Ω)	DCR(Ω)	PS	Balance	Setup
0	P01-P02			2.7340p						Pri.
1	P11-P12									A1,A2
2	P21-P22									Load Std OFF
3	P31-P32									Deviation 21/12/16 14:56
4	P11-P22									Speed Fast
5	P11-P12									Test Fail Continue
6										Focus ON
7										Split 2-1
8										Save OFF
9										
A2	Pin	Lx(H)	Lk(H)	Cp(F)	Zx(Ω)	ACR(Ω)	DCR(Ω)	PS	Balance	
0	P61-P62									
1	P11-P12									
2	P21-P22									
3	P31-P32									
4	P41-P42									
5	P51-P52									
6										
7										
8										
9										

Click the parameter title to focus scan the parameter selected.

Trans Scan										I:\files\GuideBook.t40	Setup
A1	Pin	Lx(H)	Lk(H)	Cp(F)	Zx(Ω)	ACR(Ω)	DCR(Ω)	PS	Balance		
0	P01-P02			1.3597p							
1	P11-P12			2.6370p							
2	P21-P22										
3	P31-P32										
4	P11-P22										
5	P11-P12										
6											
7											
8											
9											
A2	Pin	Lx(H)	Lk(H)	Cp(F)	Zx(Ω)	ACR(Ω)	DCR(Ω)	PS	Balance		
0	P61-P62										
1	P11-P12										
2	P21-P22										
3	P31-P32										
4	P41-P42										
5	P51-P52										
6											
7											
8											
9											

Click [Pin] to focus scan all the data to be tested on a page.

Trans Scan										I:\files\GuideBook.t40	Setup
A1	Pin	Turn-V	Lx(H)	Lk(H)	Cp(F)	Zx(Ω)	ACR(Ω)	DCR(Ω)	PS	Bala	
0	P01-P02	1.0000	-2.1207m	-3.1603	1.7227p	18.903k	1.3441M	-750.00m	3.9015M		
1	P11-P12	214.21m	506.68μ	-5.7133	3.1118p	1.7123M	1.3831M	110.00m	499.97k		
2	P21-P22	145.66m	1.2787m	-6.1429		1.5351M	1.3367M	110.00m	3.2010M		
3	P31-P32								---M		
4	P11-P22								1.0999M		
5	P11-P12								---M		
6											
7											
8											
9											
A2	Pin	Turn-V	Lx(H)	Lk(H)	Cp(F)	Zx(Ω)	ACR(Ω)	DCR(Ω)	PS	Bala	
0	P61-P62										
1	P11-P12										
2	P21-P22										
3	P31-P32										
4	P41-P42										
5	P51-P52										
6											
7											
8											
9											

## 7.15 Split

When there are few transformer test parameters, and multiple transformers need to be tested at the same time, the split function can be modified to meet the test requirements.

The split functions are:

- 2-1
- 3-1
- 4-1
- 2-2
- 3-2
- 4-2.

The default setting is **2-1**. If the table does not display all parameters, you can touch the corresponding table and slide left and right to view it, or press the left and right soft keys to view it directly.

Trans Scan											I:\files\GuideBook.t40	Setup
A1	Pin	Turn-V	Lx(H)	Lk(H)	Cp(F)	Zx(Ω)	ACR(Ω)	DCR(Ω)	PS	Bala		
0	P01-P02	1.0000	-382.87μ	-9.6958	001 - 013	11.633k	1.3556M	-750.00m	002 - 003	001-002		
1	P11-P12	207.97m	553.68μ	-9.4669	003 - 011	1.6621M	1.3588M	-890.00m	004 - 005			
2	P21-P22	146.96m	1.2310m	-4.5691		1.3641M	1.5967M	110.00m	008 - 009			
3	P31-P32								010 - 011			
4	P11-P22								012 - 013			
5	P11-P12								001 - 011			
6												
7												
8												
9												

Trans Scan											I:\files\GuideBook.t40	Setup
A1	Pin	Turn-V	Lx(H)	Lk(H)	Cp(F)	---	Pin	Turn-V	Lx(H)	Lk(H)	Cp(F)	
0	P01-P02	1.0000	-2.1207m	-3.1603	1.722							
1	P11-P12	214.21m	506.68μ	-5.7133	3.111							
2	P21-P22	145.66m	1.2787m	-6.1429								
3	P31-P32											
---	Pin	Turn-V	Lx(H)	Lk(H)	Cp(F)	---	Pin	Turn-V	Lx(H)	Lk(H)	Cp(F)	
0												
1												
2												
3												
---	Pin	Turn-V	Lx(H)	Lk(H)	Cp(F)	---	Pin	Turn-V	Lx(H)	Lk(H)	Cp(F)	
0												
1												
2												
3												

## 7.16 Frequently Asked Questions About Transformer Scans

### 7.16.1 High and Low Limits

During measuring, you find the test value of transformer is obviously and seriously unqualified, but the judge table still displays that the parameter is qualified.

**Problem:** You have only set the standard value (STD) but not the high/low limit, or just set one of the high/low limit values.

**Solution:** Set high and low limits.

### 7.16.2 Measurement Item Loss

During measuring, you find some parameter such as (Lx) is set to be tested, but the parameter is not tested and no data displays.

**Problem:** You have only set  $\sqrt{ / x }$  to  $\sqrt{ / }$ , but have not set a standard value on the parameter menu. Simultaneously, "Ignore STD Test" is set to "FORCE DEV" on [Trans ID].

**Solution:**

- Set "Ignore STD Test" to "FORCE TEST".
- Set the standard value on parameter limit setup menu.

### 7.16.3 Measurement Interruption

The instrument only tests the test parameter in the first several value groups; the last ones are not tested.

**Problem 1:** When setting the pin position, you have only configured the first groups of pins, but have not configured one or more pin group in the middle; thus the left groups will not be used in measuring; or...

**Problem 2:** On [Trans Scan], you have set "Test Fail" to "STOP", meaning that when any parameters are invalid, the test will not be performed.

**Solution:**

- Set "Test Fail" to "CONTINUE".
- Reset the blank pin on parameter limit setup menu or set "Ignore STD" to "FORCE TEST".

### 7.16.4 Poor DCR Accuracy

If the sheet metal is oxygenized, torn or deformed, or you made a fixture without applying the 4-cable test method, it will cause DCR deviation.

**Solution:**

- Keep the sheet metal intact, so it can be in good contact with the transformer pin.
- Use 4-cable measurement.
- Use deviation deduction.

### 7.16.5 Poor Lk Accuracy

If the sheet metal is oxygenized, torn or deformed, or the lead resistance of a user-made test fixture is too large, it will cause Lk deviation.

**Solution:**

- Keep the sheet metal intact, so it can be in good contact with the transformer pin.
- Use 4-cable measurement.
- Use deviation deduction.

### 7.16.6 Inaccurate TURN

For transformers with low magnetic permeability magnetic-core, the number of windings is not the same as that of real winding because the inductor will take some ACR voltage.

**Solution:** Use the TURN mode to test winding.

## 7.16.7 Unstable Turn

For a transformer with high magnetic permeability magnetic-core, test winding will be unstable.

**Solution:**

- Use the Turn\_V mode to test winding (voltage-turn mode).
- Use deviation deduction.

## 7.16.8 Difference Between the First and the Second Lx

Because a transformer with high magnetic permeability magnetic-core is polarized while measuring DCR or Turn, the measurement results of the first and the second Lx test will be quite different.

**Solution:** Use 100  $\Omega$  internal resistance when measuring DCR or Turn.

## 7.16.9 Poor Stability of Cx and Zx Open Test Data

If the shielding and ground of test system is not good, it will cause the test value to be unstable when measuring Cx or Zx.

**Solution:** Through a thick metal lead, connect the ground poles of the instrument and the scan box as well as the metal frame of the test fixture together, and ground reliably.

## 7.16.10 DCR and PS Open Cannot Increase Indefinitely

Due to the existence of circuit distribution parameter, an infinite size cannot be displayed when measuring DCR or PS open; this is a normal phenomenon. If you do wish to display it, execute the sweep open-circuit correction function on the test fixture.

## 7.17 User-Made Test Fixture

There are many kinds of transformers, which means our company can't offer a test fixture to each transformer. This requires the user to make a test fixture based on some specific principles.

The following must be kept in mind when making a test fixture:

- Use the 4-cable measurement method to extend the test cable. Don't use a 5.0 mm test fixture to hold the test lead.
- Use a multi-strand lacquer cable with good tenacity as your test extension cable, and use the stands as much as possible to minimize cable resistance.
- Use high frequency test, and reduce the distribution parameter within the extension cable; don't use a ribbon cable to extend.
- It is better to use a metal frame which is connected to the ground pole through a thick metal lead.

### 7.17.1 Use ST1801-EXT2A-OUT to Make Test Fixture

For this, you should purchase the ST1801-EXT2A extension ground board from our company. The figure below also shows the connection of using 2 spring thimble to make test probe.

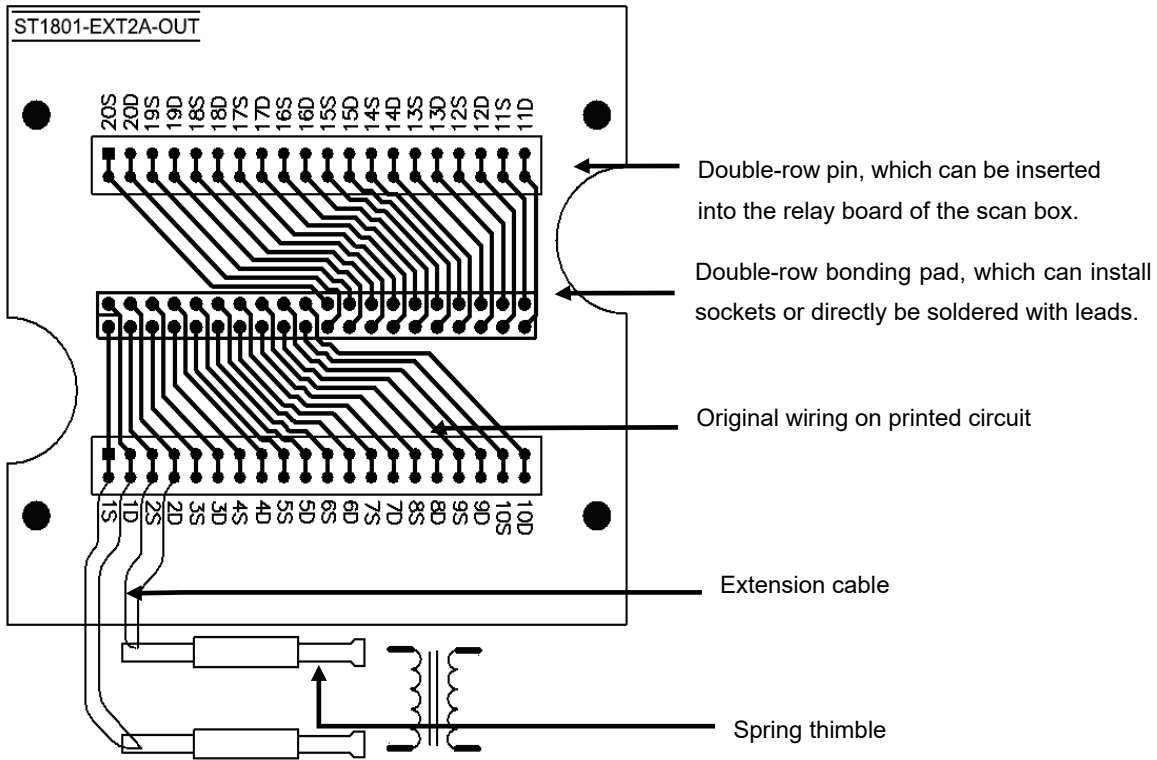

The principle of 4-cable measurement is that the test cable of DRIVE and SENSE should be divided. In this figure, 1D means the drive terminal of pin1, 1S means the sense terminal of pin1.

### 7.17.2 Example of Using ST1801-EXT11A(5.0)-B Pin Signal

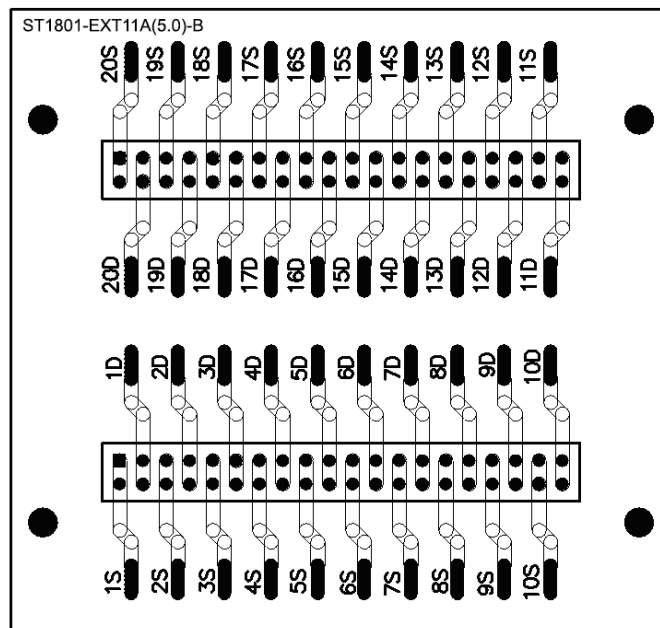



## 8 Performance and Test

### 8.1 Measurement Function

#### 8.1.1 Parameters

##### 8.1.1.1 LCR Module

Parameter Name	Parameter Meaning	Parameter Name	Parameter Meaning
Cp	Equivalent Parallel Capacitance	Cs	Equivalent Series Capacitance
Lp	Equivalent Parallel Inductance	Ls	Equivalent Series Inductance
Rp	Equivalent Parallel Resistance	Rs	Equivalent Series Resistance
Gp	Conductance	Bp	Susceptance
Z	Absolute Value Of Impedance	Y	Absolute Value Of Admittance
D	Loss Factor	Q	Quality Factor
$\theta_z^\circ$	Impedance Degree	$\theta_z$	Impedance Radian
$\theta_y^\circ$	Admittance Degree	$\theta_y$	Admittance Radian
X	Reactance	Rd	DC Resistance

##### 8.1.1.2 Transformer Single-Group Module

Parameter Name	Parameter Meaning	Parameter Name	Parameter Meaning
Cp	Equivalent Parallel Capacitance	Cs	Equivalent Series Capacitance
Lp	Equivalent Parallel Inductance	Ls	Equivalent Series Inductance
Rp	Equivalent Parallel Resistance	Rs	Equivalent Series Resistance
D	Loss Factor	Q	Quality Factor
Zx	Absolute Value Of Impedance	Rd	DC Resistance
Lk	Leakage Inductance	dZ	Impedance Angle
Ns	Secondary Turn	Ns:Np	Secondary Turn / Primary Turn
Np	Primary Turn	Np:Ns	Primary Turn / Secondary Turn

#### 8.1.2 Measurement Combination

Four parameters can be selected freely, regardless of primary and secondary parameters.

### 8.1.3 Mathematical Operation

Operation between the measurement value and the programmable nominal value:

- Absolute Deviation  $\Delta$ ABS
- Percent Deviation  $\Delta\%$

### 8.1.4 Equivalent Mode

- Series
- Parallel

### 8.1.5 Range

- Auto
- Manual (hold, increase and decrease)

### 8.1.6 Trigger Mode

**Single Trigger Mode:** Press the [TRIGGER] key on the panel, have the Handler Interface of the instrument receive an external start signal, use the foot switch or use the bus trigger command to make the instrument perform a single measurement and output the result and display it, usually in a waiting state.

**Continuous Trigger Mode:** Continuously measure the DUT and output the results for display.

### 8.1.7 Delay Time

**Trigger Delay:** The time between the trigger and the beginning of the measurement. 0 ~ 60 s; programmable; 1 ms resolution

**Step Delay:** The delay time before the measurement signal is output to the measurement. 0 ~ 60 s; programmable; 1 ms resolution.

### 8.1.8 Connection Modes of Test Terminals

ST2840X adopts a 4-terminal measurement method:

- **Hcur:** Current sample high terminal
- **Lcur:** Current sample low terminal
- **Hpot:** Voltage sample high terminal
- **Lpot:** Voltage sample low terminal

### 8.1.9 Measurement Speed (Frequency $\geq 10$ kHz)

**Fast+:** about 1800 measurements / s (0.55 ms / measurement)

**Fast:** about 300 measurements / s (3.3 ms / measurement)

**Medium:** about 11 measurements / s (90 ms / measurement)

**Slow:** about 4 measurements / s (240 ms / measurement)

The fast+, fast and medium speed will slow down when the frequency is below 10 kHz.

## 8.1.10 Average

255; programmable.

## 8.1.11 Digits Displayed

6 digits; with a max. display of 999999.

# 8.2 Measurement Signal

## 8.2.1 Measurement Signal Frequency

The measurement signal is a sine wave.

**Accuracy:** 0.01 %

**Frequency Range:**

- 20 Hz ~ 500 kHz (ST2840AX / ST2840NX)
- 20 Hz ~ 2 MHz (ST2840BX)

**Min. Resolution:** 1 mHz

## 8.2.2 Signal Mode

**Normal:** During measuring, the voltage across test terminals may be less than the preset voltage on the measurement display page.

**Constant Level:** Internal auto adjustment ensures the voltage of DUT corresponds with preset voltage.

## 8.2.3 Measurement Signal Level

	Mode	Freq	Range	Accuracy	Resolution
Voltage	Normal	$\leq 1$ MHz	5 mV <sub>rms</sub> ~ 20 V <sub>rms</sub>	$\pm 10 \% \times (\text{preset value} + 2 \text{ mV})$	100 $\mu$ V
	Constant Level	$> 1$ MHz	5 mV <sub>rms</sub> ~ 15 V <sub>rms</sub>	$\pm 6 \% \times (\text{preset value} + 2 \text{ mV})$	
Current	Normal	20 ~ 2 MHz	50 $\mu$ A <sub>rms</sub> ~ 100 mA <sub>rms</sub>	$\pm 10 \% \times (\text{preset value} + 10 \mu\text{A}_{\text{rms}})$	1 $\mu$ A
	Constant Current				

## 8.2.4 Output Impedance

Choose between 30  $\Omega \pm 4 \%$  or 100  $\Omega \pm 2 \%$ .

## 8.2.5 Monitor for Measurement Signal Level

	Frequency	Range	Accuracy
Voltage	≤ 1 MHz	5 mV <sub>rms</sub> ~ 20 V <sub>rms</sub>	± (3 % × reading + 0.5 mV)
	> 1 MHz	5 mV <sub>rms</sub> ~ 15 V <sub>rms</sub>	± (6 % × reading + 0.5 mV)
Current	≤ 1 MHz	50μA <sub>rms</sub> ~ 100 mA <sub>rms</sub>	± (3 % × reading + 5μA)
	> 1 MHz	50μA <sub>rms</sub> ~ 100 mA <sub>rms</sub>	± (6 % × reading + 5μA)

## 8.2.6 Maximum Measurement Display Range

Parameter	Display Range
L, Lk	0.00001μH ~ 99.9999 kH
C	0.00001 pF ~ 9.99999F
Z, R, X, DCR	0.00001 Ω ~ 99.9999 MΩ
Y, B, G	0.00001 μs ~ 99.9999 s
D	0.00001 ~ 9.99999
Q	0.00001 ~ 99999.9
θ	Deg -179.999° ~ 179.999°
	Rad -3.14159 ~ 3.14159
Turns Ratio	(1 : 0.001) ~ (1000 : 1)

## 8.2.7 DC Bias Voltage Source

Range	Resolution	Accuracy
0 ~ ±40 V	1 mV	1 % × preset voltage + 5 mV
0 ~ ±100 mA	10μA	–

## 8.2.8 2 A Bias Current Source

Range	Resolution	Accuracy (I > 5 mA)
0 ~ 2 A	1 mA	± (2 % × set value + 2 mA)

## 8.3 Measurement Accuracy

Measurement accuracy includes:

- Stability
- Temperature Coefficient
- Linear Degree

- Test Repeatability
- Calibration Inter-Error

Any examination of the instrument's accuracy should be under the following circumstances:

- **Warm-Up Time:**  $\geq 60$  min
- **Cable Length:** 0 m, 1 m
- Open-circuit and short-circuit correction after warming up.
- DC bias is turned OFF.
- The range is set to AUTO to select the correct measurement range.

### 8.3.1 Accuracy of $|Z|$ , $|Y|$ , L, C, R, X, G, B

The accuracy  $A_e$  of  $|Z|$ ,  $|Y|$ , L, C, R, X, G and B is expressed as:

$$A_e = \pm [A_L \times A + (K_a + K_b + K_c) \times 100 + K_d + K_f] \times K_e \quad [\%]$$

- A: Basic Measurement Accuracy (Figure 8-1)
- $A_L$ : Level Correction Factor (Table 8-1)
- $K_a$ : Impedance Rate Factor (Table 8-2; Table 8-3)
- $K_b$ : Impedance Rate Factor (Table 8-2; Table 8-4)
- $K_c$ : Calibrated Interpolating Factor (Table 8-5)
- $K_d$ : Cable Length Factor (Table 8-7)
- $K_e$ : Temperature Factor (Table 8-8)
- $K_f$ : Scan Fixture Modification Factor (no scan fixture:  $K_f = 0$ ; scan fixture:  $K_f = 0.2$ )
- L, C, X, B Accuracy  $A_e$ , using condition:  $D_x$  (test value of D)  $\leq 0.1$
- R, G Accuracy  $A_e$ , using condition:  $Q_x$  (test value of Q)  $\leq 0.1$

When  $D_x \geq 0.1$ , the accuracy factor  $A_e$  of L, C, X, B is to be multiplied by  $\sqrt{1 + D_x^2}$

When  $Q_x \geq 0.1$ , the accuracy factor  $A_e$  of R, G is to be multiplied by  $\sqrt{1 + Q_x^2}$

### 8.3.2 Accuracy of D

The accuracy of D is defined as:

$$D_e = \pm \frac{A_e}{100}$$

This formula is only available when  $D_x \leq 0.1$ . When  $D_x > 0.1$ ;  $D_e$  should be multiplied by  $(1 + D_x)$ .

### 8.3.3 Accuracy of Q

The accuracy of Q is defined as:

$$Q_e = \pm \frac{Q_x^2 \times D_e}{1 \mp Q_x \times D_e}$$

Where...

- $Q_x$  is the value of the tested Q;
- $D_e$  is the accuracy of D.

The formula should be used when  $Q_x \times D_e < 1$ .

### 8.3.4 Accuracy of $\Theta$

The accuracy of  $\theta$  is defined as:

$$\theta_e = \frac{180}{\pi} \times \frac{A_e}{100} \quad [\text{deg}]$$

### 8.3.5 Accuracy of G

When  $D_x$  (value of the tested D)  $\leq 0.1$ , the accuracy of G is defined as:

$$G_e = B_x \times D_e \quad [\text{S}]$$

$$B_x = 2\pi f C_x = \frac{1}{2\pi f L_x}$$

Where...

- $B_x$  is the value of the tested B with the unit [S];
- $C_x$  is the value of the tested C with the unit [F];
- $L_x$  is the value of the tested L with the unit [H];
- $D_e$  is the accuracy of D;
- F is the measurement frequency.

### 8.3.6 Accuracy of $R_p$

When  $D_x$  (value of the tested D)  $\leq 0.1$ , the accuracy of  $R_p$  is defined as:

$$R_{pe} = \pm \frac{R_{px} \times D_e}{D_x \mp D_e} \quad [\Omega]$$

Where...

- $R_{px}$  is the value of the tested  $R_p$  with the unit [S];
- $D_x$  is the value of the tested  $D$  with the unit [F];
- $D_e$  is the accuracy of  $D$ .

### 8.3.7 Accuracy of $R_s$

When  $D_x$  (value of the tested  $D$ )  $\leq 0.1$ , the accuracy of  $R_s$  is defined as:

$$R_s = X_x \times D_e \quad [\Omega]$$

$$X_x = 2\pi f L_x = \frac{1}{2\pi f C_x}$$

Where...

- $X_x$  is the value of the tested  $X$  with the unit [S];
- $C_x$  is the value of the tested  $C$  with the unit [F];
- $L_x$  is the value of the tested  $L$  with the unit [H];
- $D_e$  is the accuracy of  $D$ ;
- $F$  is the measurement frequency

### 8.3.8 Accuracy of DCR

$$A (1 + R_x / 5 \text{ M}\Omega + 16 \text{ m}\Omega / R_x) [\%] \pm 0.2 \text{ m}\Omega$$

At medium and slow measurement speed,  $A = 0.25$ ; at fast measurement speed,  $A = 0.5$

Here,  $R_x$  is the measured resistance.

### 8.3.9 Accuracy of Lk

$$\text{Inductance L accuracy} + 0.2 \%$$

### 8.3.10 Accuracy of Turns Ratio

$$\pm A_t \times A_r (1 + 1 \Omega / Z_p + 1 / Q) [\%] \pm 0.002$$

At medium and slow measurement speed,  $A_t = 0.25$ ; at fast measurement speed,  $A_t = 0.5$

Where...

- $Z_p$  is the impedance of the measured primary inductance;
- $A_r$  is the correction value of the measurement signal accuracy in Figure B.

This accuracy index is used when the coupling coefficient of the transformer under test is 1 or close to 1.

### 8.3.11 Accuracy Factor

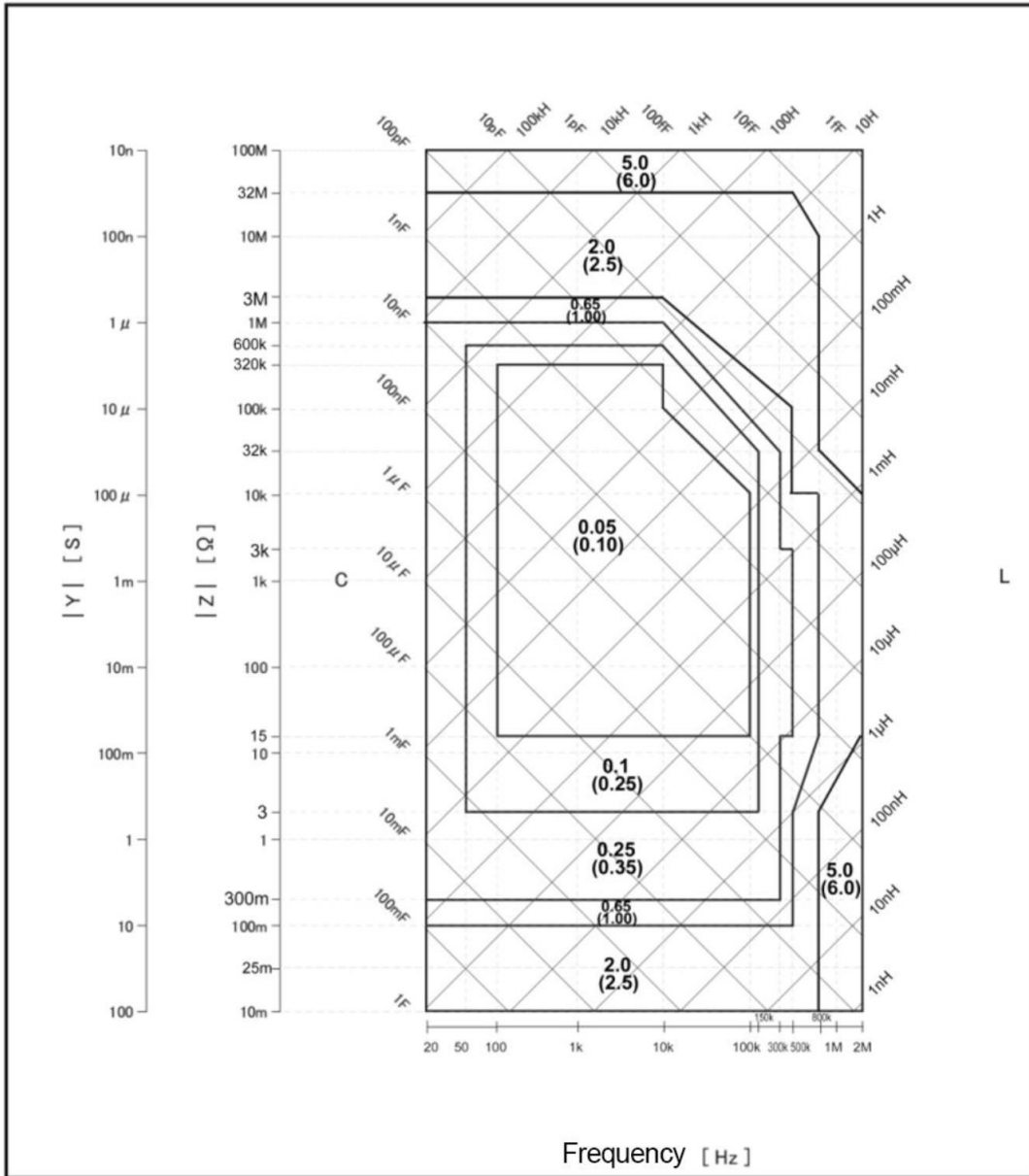

Figure 8-1 Basic Measurement Accuracy Factor A

The basic accuracy A can be read from the diagram as follows:

Determine the intersection point of the straight line corresponding to the expected measured value with the measuring frequency. Two numbers are assigned to the outlined subarea in which this crossing point is located. At slow and medium measurement speeds the upper and at fast measurement speeds the lower of the two numbers is the value of A we are looking for.

The basic measurement accuracy factor A is applicable to a measurement level range of 500 mV<sub>rms</sub> ~ 1.0 V<sub>rms</sub>. When exceeding this range, determine A as outlined above, then select the value of A<sub>L</sub> according to the table below. The final value is then obtained by calculating A<sub>L</sub> × A.

Here, V<sub>s</sub> is the measurement signal voltage.

**Note:** If all of the following measurement conditions are met, the A value is increased by 0.15.

- **Test Frequency:** 100 Hz < f<sub>m</sub> ≤ 2 MHz
- **Test Signal Voltage:** 5 V<sub>rms</sub> < V<sub>s</sub> ≤ 20 V<sub>rms</sub>
- **DUT:** Inductor, |Z<sub>m</sub>| < 200 Ω (|Z<sub>m</sub>| : DUT impedance)



Table 8-1 Correction Factor A<sub>L</sub>

Measurement Signal Voltage V <sub>s</sub> (V <sub>rms</sub> )						
V <sub>s</sub> (V <sub>rms</sub> )	[5 m, 50 m]	(50 m, 200 m]	(200 m, 500 m]	(500 m, 1]	(1, 2]	(2, 20]
A <sub>L</sub>	2.5 × 50 mV <sub>rms</sub> / V <sub>s</sub>	2.5	500 mV <sub>rms</sub> / V <sub>s</sub>	1	V <sub>s</sub>	4

Table 8-2 Impedance Rate Factors K<sub>a</sub> and K<sub>b</sub>

Speed	Frequency	K <sub>a</sub>	K <sub>b</sub>
Medium Slow	f <sub>m</sub> ≤ 1.2 kHz	$(\frac{1 \times 10^{-3}}{ Z_m })(1 + \frac{200}{V_s}) \sqrt{\frac{100}{f_m}}$	$ Z_m (0.3 \times 10^{-9})(1 + \frac{70}{V_s}) \sqrt{\frac{100}{f_m}}$
	1.2 kHz < f <sub>m</sub> ≤ 8 kHz	$(\frac{1 \times 10^{-3}}{ Z_m })(1 + \frac{200}{V_s})$	$ Z_m (1 \times 10^{-9})(1 + \frac{70}{V_s})$
	8 kHz < f <sub>m</sub> ≤ 150 kHz		$ Z_m (3 \times 10^{-9})(1 + \frac{70}{V_s})$
	150 kHz < f <sub>m</sub> ≤ 1 MHz	$(\frac{1 \times 10^{-3}}{ Z_m })(3 + \frac{200}{V_s})$	$ Z_m (10 \times 10^{-9})(1 + \frac{70}{V_s})$
Fast	f <sub>m</sub> ≤ 1.2 kHz	$(\frac{2.5 \times 10^{-3}}{ Z_m })(1 + \frac{400}{V_s}) \sqrt{\frac{100}{f_m}}$	$ Z_m (0.6 \times 10^{-9})(1 + \frac{100}{V_s}) \sqrt{\frac{100}{f_m}}$
	1.2 kHz < f <sub>m</sub> ≤ 8 kHz	$(\frac{2.5 \times 10^{-3}}{ Z_m })(1 + \frac{400}{V_s})$	$ Z_m (2 \times 10^{-9})(1 + \frac{100}{V_s})$
	8 kHz < f <sub>m</sub> ≤ 150 kHz		$ Z_m (6 \times 10^{-9})(1 + \frac{100}{V_s})$
	150 kHz < f <sub>m</sub> ≤ 1 MHz	$(\frac{2.5 \times 10^{-3}}{ Z_m })(2 + \frac{400}{V_s})$	$ Z_m (20 \times 10^{-9})(1 + \frac{100}{V_s})$

Where...

- f<sub>m</sub> is the measurement frequency; its unit is [Hz];
- The unit of the tested impedance is [Ω];
- The unit of the measurement signal voltage is [mV<sub>rms</sub>].

For impedances above 500 Ω, K<sub>a</sub> is negligible, and only K<sub>b</sub> is used; for impedances below 500 Ω, K<sub>b</sub> is negligible, and only K<sub>a</sub> is used.

**Note:** When the cable length is extended, K<sub>a</sub> should have the following value added.

Table 8-3 Added Values to K<sub>a</sub> Based on Cable Length L

Cable Length L [m]	Added Value to K <sub>a</sub>
0	0
1	0.0005
2	0.0010

**Note:** At the same time, when the cable length is extended,  $K_b$  should be multiplied the following value.

Table 8-4 Multiplied Values to  $K_b$  Based on Cable Length

Cable Length L [m]	$f_m \leq 100$ kHz	$100$ kHz $< f_m \leq 300$ kHz	$300$ kHz $< f_m \leq 1$ MHz
0	1	1	1
1	$1 + 5 \times f_m$	$1 + 2 \times f_m$	$1 + 0.5 \times f_m$
2	$1 + 10 \times f_m$	$1 + 4 \times f_m$	$1 + 1 \times f_m$

Here,  $f_m$  is the measurement frequency and its unit is [MHz].

The calibration correction data are linearly interpolated between the measured frequency points (Table 8-5). The interpolation correction factor  $K_c$  indicates the deviation between the interpolated data and the real measurement deviation between the calibration points.

Table 8-5 Calibrated Interpolating Factor  $K_c$ 

Measurement Frequency	$K_c$
Direct calibrated frequency (listed in Table 8-6)	0
Other frequency	0.0003

Table 8-6 Direct Calibrated Frequency

			20	25	30	40	50	60		80		[Hz]
100	120	150	200	250	300	400	500	600		800		[Hz]
1	1.2	1.5	2	2.5	3	4	5	6		8		[kHz]
10	12	15	20	25	30	40	50	60		80		[kHz]
100	120	150	200	250	300	400	500	600	700	800	900	[kHz]
1	1.1	1.2	1.3	1.4	1.5	1.6	1.7	1.8	1.9	2		[MHz]

**Note:** There are 60 frequencies listed in Table 8-6. The highest frequency of ST2840AX and ST2840NX is up to 500 kHz and the highest frequency of ST2840BX is up to 2 MHz.

Table 8-7 Cable Length Factor  $K_d$ 

Measurement Signal Level	Cable Length L		
	1 m	2 m	4 m
$\leq 2 V_{rms}$	$2.5 \times 10^{-4} (1 + 50 \times f_m)$	$5 \times 10^{-4} (1 + 50 \times f_m)$	$1 \times 10^{-3} (1 + 50 \times f_m)$
$> 2 V_{rms}$	$2.5 \times 10^{-3} (1 + 16 \times f_m)$	$5 \times 10^{-3} (1 + 16 \times f_m)$	$1 \times 10^{-2} (1 + 16 \times f_m)$

Here,  $f_m$  is the measurement frequency and its unit is [MHz].

Table 8-8 Temperature Factor  $K_e$ 

Temperature	$K_e$
0 ~ 18 °C	4
18 ~ 28 °C	1
28 ~ 40 °C	4

## 8.4 Performance Testing

### 8.4.1 Operating Conditions

All measurements should take place under the specific operating conditions listed in this manual, including an appropriate warm-up time (see Chapter 1.6). Only primary indexes are listed in this section.

### 8.4.2 Used Instruments and Devices

No.	Instrument/Device		Specification
1	Standard Capacitor	100 pF	0.02 % D is known
		1000 pF	
		10000 pF	
		10 nF	
		0.1 $\mu$ F	
		1 $\mu$ F	
2	AC Standard Resistor	10 $\Omega$	0.02 %
		100 $\Omega$	
		1 k $\Omega$	
		10 k $\Omega$	
		100 k $\Omega$	
3	DC Standard Resistor	0.1 $\Omega$	0.02 %
		1 $\Omega$	
		10 $\Omega$	
		100 $\Omega$	
		1 k $\Omega$	
		10 k $\Omega$	
		100 k $\Omega$	
4	Standard Inductor	100 $\mu$ H	0.02 %
		1 mH	
		10 mH	
		100 mH	
5	Frequency Counter		(0 ~ 1000) MHz
6	Digital Multimeter		0.5 %
7	Insulation Resistance Meter		500 V; 10 levels
8	High Voltage Tester		0.25 kW (0 ~ 500) V

### 8.4.3 Basic Functionality Check

Ensure that function keys, display, interfaces, etc. are operating normally.

### 8.4.4 Check the Signal Level

Connect a multimeter in the AC voltage setting between Hcur and the ground. Set the measurement level to 10 mV, 20 mV, 100 mV, 200 mV, 1 V, 2 V, 10 V and 20 V, and check that the reading is within the limits given in this chapter.

### 8.4.5 Check the Frequency

Connect a frequency meter between the ground terminal and Hcur. Set the frequency to 20 Hz, 100 Hz, 1 kHz, 10 kHz, 100 kHz, 200 kHz, 500 kHz, 1 MHz and 2 Mhz, and check that the reading is within the limits given in this chapter.

### 8.4.6 Check the Measurement Accuracy

R, L, C and D are the basic parameters, therefore the measurement accuracy is mainly defined by them.

#### 8.4.6.1 Accuracy of C and D

Function	Measurement Frequency (test each respectively)	Level	Range	Bias	Speed
C <sub>p</sub> -D	<ul style="list-style-type: none"> <li>• 100 Hz</li> <li>• 1 kHz</li> <li>• 10 kHz</li> <li>• 100 kHz</li> </ul>	1 V	AUTO	0 V	Slow

Open-circuit and short-circuit correction should be performed before measurement. Connect your standard capacitors of 100 pF, 1000 pF, 10 nF, 0.1 μF and 1 μF and measure them at the different frequencies. Check that the deviation between the readings and the standard values of C and D is within the limits given in this chapter.

#### 8.4.6.2 Accuracy of L

Function	Measurement Frequency (test each respectively)	Level	Range	Bias	Speed
L <sub>s</sub> -Q	<ul style="list-style-type: none"> <li>• 100 Hz</li> <li>• 1 kHz</li> </ul>	1 V	AUTO	0 V	Slow

Open-circuit and short-circuit correction should be performed before measurement. Connect your standard inductors of 100μH, 1 mH, 10 mH and 100 mH and measure them at the different frequencies. Check that the deviation between the reading and the standard value of L is within the limits given in this chapter.

### 8.4.6.3 Accuracy of Z

Function	Measurement Frequency (test each respectively)	Level	Range	Bias	Speed
Z- $\theta$	<ul style="list-style-type: none"> <li>• 100 Hz</li> <li>• 1 kHz</li> <li>• 10 kHz</li> <li>• 100 kHz</li> </ul>	1 V	AUTO	0 V	Slow

Open-circuit and short-circuit correction should be performed before measurement. Connect your AC standard resistors of 10  $\Omega$ , 100  $\Omega$ , 1 k $\Omega$ , 10 k $\Omega$  and 100 k $\Omega$  and measure them at the different frequencies. Check that the deviation between the reading and the standard value of  $|Z|$  is within the limits given in this chapter.

### 8.4.6.4 Accuracy of DCR

Function	Measurement Frequency	Level	Range	Bias	Speed
DCR	–	–	AUTO	–	Slow

Short-circuit correction should be performed before measurement. Connect your DC standard resistors of 0.1  $\Omega$ , 1  $\Omega$ , 10  $\Omega$ , 100  $\Omega$ , 1 k $\Omega$ , 10 k $\Omega$  and 100 k $\Omega$  and measure them at the different frequencies. Check that the deviation between the reading and the standard value of DCR is within the limits given in this chapter.

## 9 Command Reference

### 9.1 GPIB Common Commands

- \*RST
- \*TRG
- \*IDN
- \*TST
- \*ESE
- \*SRE
- \*ESR
- \*STB
- \*OPC
- \*CLS

The \*RST command resets the instrument.

For example: WrtCmd ("\*RST")

The \*TRG command triggers the measurement and then sends the result.

For example: WrtCmd ("\*TRG")

Test Page			
LCR Meter	Component Testing	Parameter 1 result, parameter 2 result, parameter 3 result, parameter 4 result, the sorting results. <b>Example:</b> 1.12345E2, 1.23456E-2, 1.11023E2, -1.12345E2,1 The sorting results take the following values:	
		<b>Sorting Results</b>	<b>Description</b>
		0	BIN OUT
	1 ~ 10	BIN 1 ~ 10	
	<b>Note:</b> The <BIN> data will only be displayed when the comparison function is turned ON.		
	List Sweep	Single-Step	Clike index, parameter 1 result, parameter 2 result, parameter 3 result, parameter 4 result, the comparison results. <b>Example:</b> 2,1.12345E2,1.23456E-2,1.11023E2,-1.12345E2,1 The comparison results take the following values:
<b>Comparison Results</b>			<b>Description</b>
0			No Comparison
1		PASS	
Other	FAIL		
Sequential	Data will be returned after all points have been tested. The data format is the same as above.		
Trace Sweep	Single-Step	Clike index, parameter 1 result, parameter 2 result, parameter 3 result, parameter 4 result. <b>Example:</b> 2, 1.12345E2, 1.23456E-2, 1.11023E2, -1.12345E2	
	Sequential	Data will be returned after all points have been tested. The data format is the same as above.	

The \*IDN? query returns the instrument ID.

**Query Syntax:** \*IDN?

**Return Format:** <model>, <firmware>, <sn>, <date>

Where...

- <model> Instrument Model (ST2840)
- <firmware> Firmware Version (VER1.0.0)
- <sn> Instrument serial number (sn12345678)
- <date> Software release date (e.g. 2024-03-14)

## 9.2 SCPI Command

SCPI (Standard Command for Programmable Instruments) is an ASCII-based instrument command language used in test and measurement instruments. SCPI commands are based on a hierarchical structure (also known as a tree system).

In this system, related commands are grouped under a common node or root, thus forming a subsystem.

According to the command syntax, most commands (and some parameters) are represented by a mixture of uppercase and lowercase letters. Uppercase letters indicate the abbreviation of the command.

For shorter program lines, you can send commands in abbreviated format; if you want better program readability, you can send long format commands.

**Note:** To avoid misunderstanding of abbreviations, the command descriptions will avoid excessive abbreviations as much as possible. Most of the command descriptions are given directly in abbreviated form.

### Grammatical Conventions:

[SOURce[1|2]:]VOLTage:UNIT {VPP|Vrms|DBM}

[SOURce[1|2]:]FREQuency:CENTer {<frequency>|MINimum|MAXimum|DEFault}

### Note: Command Syntax Conventions

Braces (curly brackets) { } contain the parameter options for the given command string. Braces are not sent with the command string.

A vertical bar | separates multiple parameter selections for a given command string. For example, in the above command, {VPP|Vrms|DBM} means you can specify "VPP", "Vrms" or "DBM". The bars are not sent with the command string.

- The angle brackets < > in the second example indicate that you must specify a value for the parameter inside these brackets. For example, in the above syntax statement, the parameter in angle brackets is <frequency>. Angle brackets are not sent with the command string. You must specify a value for the parameter (for example "FREQ: CENT 1000") unless you choose another option (such as "FREQ: CENT MIN") that appears in the syntax.
- Some syntax elements (such as nodes and parameters) are enclosed in square brackets [ ]. This means that the element is optional and can be omitted. Square brackets are not sent with the command string. If no value is specified for the optional parameter, the instrument will choose the default value. In the above example, "SOURce[1|2]" means that you can refer to source channel 1 by "SOURce" or "SOURce1", or "SOUR1" or "SOUR". Also, since the entire SOURce node is optional (in square brackets), you can also refer to channel 1 by completely omitting the SOURce node. This is because channel 1 is already the default channel for the SOURce language node. On the other hand, to refer to channel 2, you must use "SOURce2" or "SOUR2" in the program line.

The abbreviations and shorthands used in this manual are as follows:

- **NR1**: integer, e.g.:123
- **NR2**: fix-point number, e.g.: 12.3
- **NR3**: floating-point number, e.g.: 12.3E+5
- **NL**: carriage key, integer: 10
- **END**: EOI signal in IEEE-488

Subsystem commands of this series of instruments:

- DISPlay
- ORESister
- TRIGger
- CORRection
- FREQuency
- BIAS
- INITiate
- COMParator
- VOLTage
- FUNCtion
- FETCh?
- Mass MEMory
- CURRent
- LIST
- ABORT
- TRAN
- AMPLitude
- APERture
- STATus

## 9.2.1 DISPlay Subsystem Commands

Used to control page switching.

### Command Syntax:

:DISP:PAGE?

:DISP:PAGE <PageName>



**Parameter:** The meaning of the value of PageName is shown in the following table.

Page Name	Meaning	Query Return Content
MEASurement	Measurement Display	MEASurement
LIST	List Display	LIST
TSMEas	Trace Sweep Display	TSMEas
MSETup	Measurement Setup	MSETup
LTABLE	Limit Setup	LTABLE
LSETup	List Setup	LSETup
TSSETup	Trace Setup	TSSETup
CSETup	Correction Setup	CSETup
SYSTem	System Setup	SYSTem
FLISt	File List	FLISt
TMDisp	Transformer Single Group Measurement Display	TMDisp
TTSet	Transformer Single Group Measurement Setup	TTSet
TSDisp	Transformer Scan Test Page	TSDisp
TSID	Transformer Scan ID Page	TSID
TSP2P	Transformer Pin To Fixture Page	TSP2P
TSPTO1831	–	TSPTO1831
TSPTO1901	–	TSPTO1901
TSP	Transformer Pin Page	TSP
TSCON	Transformer Test Condition Page	TSCON
TSDEV	Transformer Deviation Deduction Page	TSDEV
TSCOPY	Transformer Quick Setup	TSCOPY
TSSTAT	Transformer Statistics Page	TSSTAT
TSTOOL	Transformer Tool Page	TSTOOL
TSBOXSELF	Scan and Self-Test Page	TSBOXSELF
TSHAND	Transformer Sorting Setup	TSHAND

**Example:**

:DISP:PAGE MEAS                   Enter the measurement display page;  
:DISP:PAGE MSET                   Enter the measurement setup page;  
:DISP:PAGE?                       Return the currently displayed page, please refer to the table above.

## 9.2.2 FREQUENCY Subsystem Commands

Used to set the measurement frequency of the instrument.

### Command Syntax:

:FREQ?

:FREQ <float | MIN | MAX>

### Parameter:

float	Represents the floating-point data
MIN	Set the minimum possible value
MAX	Set the maximum possible value

### Example:

:FREQ 1200	Set the frequency to 1200 Hz
:FREQ 1200HZ	Set the frequency to 1200 Hz
:FREQ 1.2K	Set the frequency to 1200 Hz
:FREQ?	Return the current frequency

## 9.2.3 VOLTage Subsystem Commands

### 9.2.3.1 AC Voltage

Used to set the AC voltage of the instrument.

### Command Syntax:

:VOLT?

:VOLT <float | MIN | MAX>

### Parameter:

float	Represents the floating-point data
MIN	Set the minimum possible value
MAX	Set the maximum possible value

### Example:

:VOLT 1.2	Set the AC voltage to 1.2 V
:VOLT?	Return the current AC voltage

### 9.2.3.2 DC Voltage

Used to set the DC voltage of the instrument.

### Command Syntax:

:VOLT:DC?

:VOLT:DC <float | MIN | MAX>

**Parameter:**

float	Represents the floating-point data
MIN	Set the minimum possible value
MAX	Set the maximum possible value

**Example:**

:VOLT:DC 1.2	Set the DC voltage to 1.2 V
:VOLT:DC?	Return the current DC voltage

## 9.2.4 CURRent Subsystem Commands

Used to set the measurement level current of the instrument.

**Command Syntax:**

```
:CURR?
:CURR <float | MIN | MAX>
```

**Parameter:**

float	Represents the floating-point data
MIN	Set the minimum possible value
MAX	Set the maximum possible value

**Example:**

:CURR 0.01	Set the measurement level to 10 mA
:CURR?	Return the level current

## 9.2.5 AMPLitude Subsystem Commands

Used to set the measurement speed and average times of the instrument.

**Command Syntax:**

```
:APER?
:APER <FAST+ | FAST | MED | SLOW> [,int]
```

**Parameter:**

FAST+	Fast+
FAST	Fast
MED	Medium
SLOW	Slow
int	Represent the value of the integer, ranging from 1 to 255

**Example:**

:APER FAST+	Set the measurement speed to fast+
:APER FAST	Set the measurement speed to fast
:APER MED	Set the measurement speed to medium
:APER SLOW	Set the measurement speed to slow
:APER FAST, 2	Set the measurement speed to fast, and average 2 times

## 9.2.6 OUTPut Subsystem Commands

### 9.2.6.1 Bias Source

Used to set the DC bias source of the instrument.

**Command Syntax:**

```
:OUTP:HPOW?
:OUTP:HPOW <INT | OPT | EXT>
```

**Parameter:**

INT	Internal 100 mA bias source
OPT	Internal 2 A bias source
EXT	External bias source

**Example:**

:OUTP:HPOW INT	Set the internal 100 mA bias source
:OUTP:HPOW OPT	Set the internal 2 A bias source
:OUTP:HPOW EXT	Set the external bias source
:OUTP:HPOW?	Return the bias source mode

### 9.2.6.2 DC Isolation

Used to set the DC isolation function switch of the instrument

**Command Syntax:**

```
:OUTP:DC:ISOL?
:OUTP:DC:ISOL <0 | 1 | OFF | ON>
```

**Parameter:**

0   OFF	OFF
1   ON	ON

**Example:**

:OUTP:DC:ISOL 0	Turn OFF DC isolation
:OUTP:DC:ISOL 1	Turn ON DC isolation
:OUTP:DC:ISOL?	Return the DC isolation function status



**Parameter:**

float	Represents the floating-point data
MIN	Set the minimum possible value
MAX	Set the maximum possible value

**Example:**

:BIAS:CURR 0.01	Set the bias current to 10 mA
:BIAS:CURR?	Return the current bias current

**9.2.7.4 Bias Polarity**

Used to set the bias polarity of the instrument.

**Command Syntax:**

```
:BIAS:POL:AUTO?
:BIAS:POL:AUTO <0 | 1 | AUTO | FIX>
```

**Parameter:**

0   AUTO	AUTO
1   FIX	FIX

**Example:**

:BIAS:POL:AUTO 0	Set the bias polarity to AUTO
:BIAS:POL:AUTO 1	Set the bias polarity to FIX
:BIAS:POL:AUTO?	Return bias polarity status

**9.2.8 TRIGger Subsystem Commands****9.2.8.1 Trigger Command****Command Syntax:**

```
:TRIG
```

**Example:**

```
:TRIG          Trigger the instrument to measure once
```

**9.2.8.2 Trigger Mode**

Used to set the trigger source mode of the instrument.

**Command Syntax:**

```
:TRIG:SOUR?
:TRIG:SOUR <CONT | SING>
```

**Parameter:**

CONT	Continuous
SING	Single

**Example:**

:TRIG:SOUR CONT	Set to continuous trigger
:TRIG:SOUR SING	Set to single trigger
:TRIG:SOUR?	Return the trigger mode

**9.2.8.3 Trigger Delay**

Used to set the trigger delay time of the instrument.

**Command Syntax:**

```
:TRIG:DEL?
:TRIG:DEL <float | MIN | MAX>
```

**Parameter:**

float	Represents the floating-point data
MIN	Set the minimum possible value
MAX	Set the maximum possible value

**Example:**

:TRIG:DEL 0	Set the trigger delay to 0
:TRIG:DEL 1ms	Set the trigger delay to 1 ms
:TRIG:DEL 1	Set the trigger delay to 1 s
:TRIG:DEL?	Return the trigger delay time

**9.2.8.4 Trigger Status Query**

Used to get the trigger status of the instrument.

**Command Syntax:**

```
:TRIGger:STATus?
```

**Parameters:**

RUN 0	...means idle or end of test
RUN 1	...means the test is running and has not yet finished

**Example:**

```
:TRIG:STAT? Returns RUN 0 or RUN 1 (return immediately)
```

**Note:** This instruction applies to the case where the test time is long and the host computer does not know the waiting time. It can constantly detect this state, and if, after the state becomes 0, you query the test results, you will receive the value of the test results immediately.

### 9.2.8.5 Trigger Reset

Equivalent to the panel reset button; used to set the pause or end of the instrument.

**Command Syntax:**

:TRIGger:ReSet

**Example:**

:TRIG:RST?

### 9.2.9 AMPLitude Auto Level Subsystem Commands

Used to turn on/off the automatic level control (ALC) function of the instrument.

**Command Syntax:**

:AMPL:ALC?

:AMPL:ALC <0 | 1 | OFF | ON>

**Parameter:**

0   OFF	OFF
1   ON	ON

**Example:**

:AMPL:ALC 0	Turn OFF automatic level control
:AMPL:ALC 1	Turn ON automatic level control
:AMPL:ALC?	Return the automatic level control function status

### 9.2.10 Output RESister Internal Resistance Subsystem Commands

Used to set the output resistance mode of the instrument.

**Command Syntax:**

:ORES?

:ORES <100 | 30>

**Parameter:**

100	Set the output resistance of the instrument to 100 $\Omega$
30	Set the output resistance of the instrument to 30 $\Omega$

**Example:**

:ORES 100	Set the output resistance of the instrument to 100 $\Omega$
:ORES 30	Set the output resistance of the instrument to 30 $\Omega$
:ORES?	Return the output internal resistance of the instrument



## 9.2.11 FUNCTION Subsystem Commands

### 9.2.11.1 Function Parameter

Used to configure the "function" parameters of the instrument.

#### Command Syntax:

```
:FUNC:IMP [1 | 2 | 3 | 4]?
```

```
:FUNC:IMP <para1, para2, para3, para4>
```

```
:FUNC:IMP <1 | 2 | 3 | 4> <para>
```

```
:FUNC:IMPSW <0 | 1>, <0 | 1>, <0 | 1>, <0 | 1>
```

```
:FUNC:IMPSW?
```

#### Parameter:

para1, para2, para3, para4                      Indicates the optional function parameter name; the values are as follows:

Parameter Name	Parameter Meaning	Parameter Name	Parameter Meaning
CP	Equivalent Parallel Capacitance	CS	Equivalent Series Capacitance
LP	Equivalent Parallel Inductance	LS	Equivalent Series Inductance
RP	Equivalent Parallel Resistance	RS	Equivalent Series Resistance
GP	Conductance	BP	Susceptance
Z	Absolute Value of Impedance	Y	Absolute Value of Admittance
D	Loss Factor	Q	Quality Factor
ZTD/DZ	$\Theta_z^\circ$ Impedance Degree	ZTR/RZ	$\Theta_z$ Impedance Radian
YTD/DY	$\Theta_y^\circ$ Admittance Degree	YTR/RY	$\Theta_y$ Admittance Radian
X	Reactance	RD	DC Resistance

#### Example:

```
:FUNC:IMP CP, CS, LP, LS                      Set 4 parameter functions at the same time
:FUNC:IMP 1 RP                                  Set parameter 1 to RP
:FUNC:IMP 2 RS                                  Set parameter 1 to RS
:FUNC:IMP 3 Z                                   Set parameter 1 to Z
:FUNC:IMP 4 Y                                   Set parameter 1 to Y
:FUNC:IMP 1?                                   Return the function of parameter 1
:FUNC:IMP 2?                                   Return the function of parameter 2
:FUNC:IMP 3?                                   Return the function of parameter 3
:FUNC:IMP 4?                                   Return the function of parameter 4
:FUNC:IMP?                                      Return the functions of all 4 parameters
:FUNC:IMPSW 1, 1, 0, 0                        Turn parameters 1 and 2, turn off parameters 3 and 4
:FUNC:IMPSW 1, 0, 0, 0                        Turn on parameter 1, turn off parameters 2, 3 and 4
```

:FUNC:IMPSW 1, 1, 1, 1	Turn on all 4 parameters
:FUNC:IMPSW?	Return the on/off status of all 4 parameters (returns e.g. "1, 0, 0, 0")

### 9.2.11.2 AC Range

Used to set the AC range of the instrument.

#### Command Syntax:

```
:FUNC:IMP:RANG?
:FUNC:IMP:RANG <float>
```

#### Parameter:

float Indicates the floating point number, refer to the value of the equivalent resistance of the DUT.

#### Example:

:FUNC:IMP:RANG 1k	Select the best range for 1 k $\Omega$ equivalent resistance
:FUNC:IMP:RANG 1000	Select the best range for 1 k $\Omega$ equivalent resistance
:FUNC:IMP:RANG 1200	Select the best range for 1.2 k $\Omega$ equivalent resistance
:FUNC:IMP:RANG?	Return the current AC range

### 9.2.11.3 AC Auto Range

Used to turn on/off the AC range auto mode of the instrument.

#### Command Syntax:

```
:FUNC:IMP:RANG:AUTO?
:FUNC:IMP:RANG:AUTO <0 | 1 | OFF | ON>
```

#### Parameter:

0 | OFF (AUTO mode) OFF  
1 | ON (AUTO mode) ON

#### Example:

:FUNC:IMP:RANG:AUTO 0	Set the AC range mode to FIX
:FUNC:IMP:RANG:AUTO 1	Set the AC range mode to AUTO
:FUNC:IMP:RANG:AUTO?	Return the AC range auto mode status

### 9.2.11.4 DC Range

Used to set the DC range of the instrument.

#### Command Syntax:

```
:FUNC:DCR:RANG?
:FUNC:DCR:RANG <float>
```

**Parameter:**

float Indicates the floating point number, refer to the value of the equivalent resistance of the DUT.

**Example:**

:FUNC:DCR:RANG 1k Select the best range for 1 kΩ DCR  
 :FUNC:DCR:RANG 1000 Select the best range for 1 kΩ DCR  
 :FUNC:DCR:RANG 1200 Select the best range for 1.2 kΩ DCR  
 :FUNC:DCR:RANG? Return the current DC range

**9.2.11.5 VI Monitoring**

Used to turn on/off the voltage monitoring of the instrument.

**Command Syntax:**

:FUNC:SMON:VAC?  
 :FUNC:SMON:VAC <0 | 1 | OFF | ON>

**Parameter:**

0 | OFF OFF  
 1 | ON ON

**Example:**

:FUNC:SMON:VAC 0 Turn OFF voltage monitoring  
 :FUNC:SMON:VAC 1 Turn ON voltage monitoring  
 :FUNC:SMON:VAC? Return the voltage monitoring status

**9.2.11.6 Current Monitoring**

Used to turn on/off the current monitoring of the instrument.

**Command Syntax:**

:FUNC:SMON:IAC?  
 :FUNC:SMON:IAC <0 | 1 | OFF | ON>

**Parameter:**

0 | OFF OFF  
 1 | ON ON

**Example:**

:FUNC:SMON:IAC 0 Turn OFF current monitoring  
 :FUNC:SMON:IAC 1 Turn ON current monitoring  
 :FUNC:SMON:IAC? Return the current monitoring switch status

### 9.2.11.7 Deviation and Reference

Used to set the deviation measurement mode of the instrument.

#### Command Syntax:

```
:FUNC:DEV [1 | 2 | 3 | 4] :MODE?
```

```
:FUNC:DEV [1 | 2 | 3 | 4] :MODE <ABS | PER | OFF>
```

#### Parameter:

ABS	$\Delta$ Absolute deviation
PER	$\Delta\%$ percent deviation
OFF	OFF

#### Example:

:FUNC:DEV 1:MODE ABS	Set parameter 1 to absolute deviation
:FUNC:DEV 2:MODE PER	Set parameter 2 to percentage deviation
:FUNC:DEV 3:MODE OFF	Turn OFF the deviation mode of parameter 3
:FUNC:DEV:MODE OFF, PER, ABS, OFF	Set the deviation modes of all 4 parameters at the same time
:FUNC:DEV 2:MODE?	Return the deviation mode of parameter 2
:FUNC:DEV:MODE?	Return the deviation modes of all 4 parameters

### 9.2.11.8 Reference Value

Used to set the reference value of the deviation of the instrument.

#### Command Syntax:

```
:FUNC:DEV [1 | 2 | 3 | 4] :REF?
```

```
:FUNC:DEV [1 | 2 | 3 | 4] :REF <float>
```

```
:FUNC:DEV <1 | 2 | 3 | 4> :REF:FILL
```

#### Parameter:

float	Represents the floating-point data
-------	------------------------------------

#### Example:

:FUNC:DEV 1:REF 10	Set the deviation reference of parameter 1 to 10
:FUNC:DEV 2:REF:FILL	Measure once; the result of parameter 2 is used as the deviation reference value
:FUNC:DEV 4:REF?	Return the deviation reference value of parameter 4
:FUNC:DEV:REF?	Return the deviation reference values of all 4 parameters
:FUNC:DEV:REF 10, 11, 12, 13	Set the deviation reference values of all 4 parameters at the same time

### 9.2.11.9 Step Delay

Used to set the step delay time of the instrument.

**Command Syntax:**

:FUNC:SDEL?

:FUNC:SDEL<float | MIN | MAX>

**Parameter:**

float	Represents the floating-point data
MIN	Set the minimum possible value
MAX	Set the maximum possible value

**Example:**

:FUNC:SDEL 0	Set the step delay to 0
:FUNC:SDEL 1ms	Set the step delay to 1 ms
:FUNC:SDEL 1	Set the step delay to 1 s
:FUNC:SDEL?	Return the step delay value;

## 9.2.12 COMPArator Subsystem Commands

### 9.2.12.1 Comparator Function

Used to turn on/off the comparator function of the instrument.

**Command Syntax:**

:COMP?

:COMP <0 | 1 | OFF | ON>

**Parameter:**

0   OFF	OFF
1   ON	ON

**Example:**

:COMP 0	Turn OFF the comparator function
:COMP 1	Turn ON the comparator function
:COMP?	Return the comparator function status

### 9.2.12.2 Counting Function

Used to turn on/off the comparison counting function of the instrument.

**Command Syntax:**

:COMP:COUN?

:COMP:COUN <0 | 1 | OFF | ON>

**Parameter:**

0   OFF	OFF
1   ON	ON

**Example:**

:COMP:COUN 0	Turn OFF the comparison count function
:COMP:COUN 1	Turn ON the comparison count function
:COMP:COUN?	Return the comparison count function status

**9.2.12.3 Query the BIN Count Comparison Result****Command Syntax:**

:COMP:COUN:DATA?

**Example:**

:COMP:COUN:DATA?                      Return the count result of each BIN

**9.2.12.4 Clear All BIN Count Results****Command Syntax:**

:COMP:COUN:CLE

**Example:**

:COMP:COUN: CLE                      Clear all count results

**9.2.12.5 Limit Mode**

Used to set the instrument's comparison limit mode.

**Command Syntax:**

:COMP:MODE?

:COMP:MODE &lt;TOL | SEQ&gt;

**Parameter:**

TOL	Tolerance mode
SEQ	Sequential mode

**Example:**

:COMP:MODE TOL	Set the comparison limit to tolerance mode
:COMP:MODE SEQ	Set the comparison limit to sequential mode
:COMP:MODE?	Return the comparison limit mode

### 9.2.12.6 Tolerance Mode Limit Values

Used to set the upper and lower limit values of each BIN in the tolerance mode of the comparison function (this function is accessible when the limit mode is set to tolerance mode).

#### Command Syntax:

```
:COMP:TOL:BIN <n>?
```

```
:COMP:TOL:BIN <n> <lowA, highA> [...], lowD, highD]
```

#### Parameter:

n	BIN number index, the value is 1 ~ 10
low <sub>A</sub>	Represents the floating-point number of low limit of parameter 1
high <sub>A</sub>	Represents the floating-point number of high limit of parameter 1
low <sub>D</sub>	Represents the floating-point number of low limit of parameter 4
high <sub>D</sub>	Represents the floating-point number of high limit of parameter 4

#### Example:

:COMP:TOL:BIN 1 1, 2	Set the upper and lower limits of the first parameter of BIN 1 to [1,2]
:COMP:TOL:BIN 3 1, 2, 3, 4	Set the upper and lower limits of the first two parameters of BIN 3 to [1,2],[3,4]
:COMP:TOL:BIN 10 1, 2, 3, 4, 5, 6, 7, 8	Set the upper and lower limits of 4 parameters of 10 BINs
:COMP:TOL:BIN 1?	Return the upper and lower limits corresponding to the 4 parameters of BIN 1

### 9.2.12.7 Sequential Mode Limit Values

Used to set the upper and lower limit data of the sequential mode of the comparison function (this function is accessible when the limit mode is set to sequential mode).

#### Command Syntax:

```
:COMP:SEQ:BIN [A | B | C | D]?
```

```
:COMP:SEQ:BIN [A | B | C | D] <lo1> [, hi1, hi2,..., hi10]
```

#### Parameter:

A   B   C   D	Indicates the corresponding number of parameters in the 4 parameters
lo <sub>1</sub>	Represents the floating point data of the lower limit of BIN 1
hi <sub>1</sub> ...hi <sub>10</sub>	Represents the floating-point numbers of the upper limit of each BIN

#### Example:

:COMP:SEQ:BIN 1, 2, 3, 4, 5	Set the first parameter lo <sub>1</sub> ,hi <sub>1</sub> ,hi <sub>2</sub> ,hi <sub>3</sub> ,hi <sub>4</sub>
:COMP:SEQ:BIN A 1, 2, 3, 4, 5	Same as above
:COMP:SEQ:BIN B 1, 2, 3, 4, 5, 6	Set the second parameter lo <sub>1</sub> ,hi <sub>1</sub> ,hi <sub>2</sub> ,hi <sub>3</sub> ,hi <sub>4</sub> ,hi <sub>5</sub>
:COMP:SEQ:BIN C 1, 2, 3, 4, 5, 6, 7, 8, 9, 10, 11	Set the upper and lower limits of the third parameter of each BIN
:COMP:SEQ:BIN?	Return the upper and lower limits of parameter 1, BIN 1 and the upper limits of other BINs
:COMP:SEQ:BIN A?	Same as above; default

:COMP:SEQ:BIN B?	Return the upper and lower limits of parameter 2, BIN 1, and the upper limits of other BINs
:COMP:SEQ:BIN C?	Return the upper and lower limits of parameter 3, BIN 1 and the upper limits of other BINs
:COMP:SEQ:BIN D?	Return the upper and lower limits of parameter 4, BIN 1 and the upper limits of other BINs

### 9.2.12.8 Clear Table

Used to clear the limit setting data of each BIN.

#### Command Syntax:

```
:COMP:BIN:CLE
```

#### Example:

```
:COMP:BIN:CLE          Clear the limit data in the table
```

### 9.2.12.9 BIN Comparator Function

Used to turn on/off the comparator function of a specified BIN.

#### Command Syntax:

```
:COMP:BIN <n> :SW?
```

```
:COMP:BIN <n>:SW <0 | 1 | OFF | ON>
```

#### Parameter:

n	BIN number index, the value is 1 ~ 10
0   OFF	OFF
1   ON	ON

#### Example:

:COMP:BIN 1:SW 0	Turn OFF the comparator function of BIN 1
:COMP:BIN 2:SW 1	Turn ON the comparator function of BIN 2
:COMP:BIN 10:SW?	Return the BIN 10 comparator function status

## 9.2.13 LIST Subsystem Commands

### 9.2.13.1 Total Sweep Points

Used to set the total number of scan points in the list.

#### Command Syntax:

```
:LIST:TOTAL?
```

```
:LIST:TOTAL <int>
```

#### Parameter:

int	The total number of scan points; the value range is 1 ~ 201
-----	---



**Example:**

:LIST:TOTAL 8	Set the list sweep points to 8
:LIST:TOTAL 201	Set the list sweep points to 201
:LIST:TOTAL?	Return the number of sweep points in the list

**9.2.13.2 List Sweep Mode**

Used to set the list sweep mode of the instrument.

**Command Syntax:**

```
:LIST:MODE?
:LIST:MODE <SEQ | STEP>
```

**Parameter:**

SEQ	Sequential
STEP	Single-Step

**Example:**

:LIST:MODE SEQ	Set to sequential mode
:LIST:MODE STEP	Set to single-step mode
:LIST:MODE?	Return the list sweep mode

**9.2.13.3 List Scan Comparator Function**

Used to turn on/off the the list scan comparator function.

**Command Syntax:**

```
:LIST:COMP?
:LIST:COMP <0 | 1 | OFF | ON>
```

**Parameters:**

0   OFF	OFF
1   ON	ON

**Example:**

:LIST:COMP 0	Turn ON list scan comparator function
:LIST:COMP OFF	Turn OFF list scan comparator function
:LIST:COMP?	Return list scan comparator function current status

### 9.2.13.4 LISTDELTA Interpolation Mode

Used to turn on/off list scan parameter interpolation mode.

#### Command Syntax:

:LISTDELTA:SW?

:LISTDELTA:SW <0 | 1 | OFF | ON>

#### Parameter:

0   OFF	OFF
1   ON	ON

#### Example:

:LISTDELTA:SW 0	Turn ON list scan interpolation mode
:LISTDELTA:SW OFF	Turn OFF list scan interpolation mode
:LISTDELTA:SW?	Return the current status of the list scan interpolation mode

### 9.2.13.5 LISTDELTA Difference Mode

Used to set the difference mode of parameter 1 of each scan point when the list scan interpolation mode is on.

#### Command Syntax:

:LISTDELTA:MODE [n]?

:LISTDELTA:MODE [n] <mode>

#### Parameter:

<n> can take any value between 1 ~ 201 (total number of scanned points)

<mode> can take any of the values 0, 1, 2, 3, 4, 5, 6, 7, 8, 9:

0	Mode $(P_n - P_1)$
1	Mode $(P_n - P_1) / P_1$
2	Mode $(P_n - P_1) / P_1 \times 100 \%$
3	Mode $(P_n - P_1) / P_n$
4	Mode $(P_n - P_1) / P_n \times 100 \%$
5	Mode $(P_n)$
6	Mode $(P_n - P_2) / P_2$
7	Mode $(P_n - P_2) / P_2 \times 100 \%$
8	Mode $(P_n - P_2) / P_n$
9	Mode $(P_n - P_2) / P_n \times 100 \%$

#### Example:

:LISTDELTA:MODE 2 0	Set the difference mode of scan point 2 to $(P_n - P_1)$ , i.e., $P_2 - P_1$
:LISTDELTA:MODE 2?	Return the current interpolation mode of list scan point 2

### 9.2.13.6 LISTDELTA Lower Limit

Used to set the lower limit of the difference corresponding to the interpolation mode of the scan point when the list scan interpolation mode is on.

**Command Syntax:**

```
:LISTDELTA:LOW [n]?
```

```
:LISTDELTA:LOW [n] <value>
```

**Parameter:**

<n> can take any value between 3 ~ 201 (total number of scanned points);

<value> takes the value type NR3.

**Example:**

```
:LISTDELTA:MODE 3 0          Set the difference mode of scan point 3 to  $(P_n - P_1)$  i.e.  $P_3 - P_1$ 
:LISTDELTA :LOW 3 -1         Based on the previous command, set the list scan interpolation mode on, and the difference mode of scan point 3 is  $(P_3 - P_1)$ , and the lower limit of this difference is -1, and its unit is the same as that of parameter 1
:LISTDELTA:LOW 3?           Return the lower limit of the current interpolation mode of list scan point 3
```

### 9.2.13.7 LISTDELTA Upper Limit

Used to set the upper limit of the difference that corresponds to the interpolation mode of the scan point when the list scan interpolation mode is on.

**Command Syntax:**

```
:LISTDELTA:HIGH [n]?
```

```
:LISTDELTA:HIGH [n] <value>
```

**Parameter:**

<n> can take any value between 1 ~ 201 (total number of sampled points);

<value> takes the value type NR3.

**Example:**

```
:LISTDELTA:MODE 3 0          Set the difference mode of scan point 3 to  $(P_n - P_1)$ , i.e.  $P_3 - P_1$ 
:LISTDELTA:HIGH 3 10         Based on the previous command, the list scan interpolation mode is turned on, the difference mode of scan point 3 is  $(P_3 - P_1)$ , and the upper limit of this difference is 10. Its unit is the same as that of parameter 1
:LISTDELTA:HIGH 3?           Return the upper limit of the current interpolation mode of list scan point 3
```

### 9.2.13.8 List Scan Parameter Display

Used to turn on/off the list scan parameter display.

**Command Syntax:**

```
:LIST:DISP:PARA?
```

```
:LIST:DISP:PARA <0 | 1>, <0 | 1>, <0 | 1>, <0 | 1>, <0 | 1>, <0 | 1>
```

**Parameter:**

0   OFF	Parameter display OFF; i.e. do not display, save or report the data
1   ON	Parameter display ON

**Example:**

:LIST. DISP:PARA 1, 0, 0, 0	Configure the four parameters to turn ON the display for only the first one
:LIST:DISP:PARA 1, 1, 0, 0	Configure the four parameters to turn ON the display for only the first two
:LIST:DISP:PARA?	Return the display status of each of the four parameters

### 9.2.13.9 List Scan Frequency Display

Used to turn on/off the list scan frequency display.

**Command Syntax:**

```
:LIST. DISP:FREQ?
```

```
:LIST:DISP:FREQ <0 | 1 | OFF | ON>
```

**Parameter:**

0   OFF	OFF
1   ON	ON

**Example:**

:LIST:DISP:FREQ 1	Turn ON the frequency display
:LIST:DISP:FREQ 0	Turn OFF the frequency display
:LIST:DISP:FREQ?	Return the frequency display status

### 9.2.13.10 List Scan AC Level Display

Used to turn on/off the list scan AC level display.

**Command Syntax:**

```
:LIST:DISP:ACLV?
```

```
:LIST:DISP:ACLV <0 | 1 | OFF | ON>
```

**Parameter:**

0   OFF	OFF
1   ON	ON

**Example:**

:LIST:DISP:ACLV 1                    Turn ON the AC level display  
 :LIST:DISP:ACLV 0                    Turn OFF the AC level display  
 :LIST:DISP:ACLV?                    Return the AC level display status

**9.2.13.11 List Scan Bias Display**

Used to turn on/off the list scan bias display.

**Command Syntax:**

:LIST:DISP:BIAS?  
 :LIST:DISP:BIAS <0 | 1 | OFF | ON>

**Parameter:**

0 | OFF                                OFF  
 1 | ON                                 ON

**Example:**

:LIST:DISP:BIAS 1                    Turn ON the bias display  
 :LIST:DISP:BIAS 0                    Turn OFF the bias display  
 :LIST:DISP:BIAS?                    Return the bias display status

**9.2.13.12 Clear**

Used to clear the setting data of all sweep points.

**Command Syntax:**

:LIST:CLE [n | ALL]

**Parameter:**

n                                        Specify the corresponding point of the list, the value is 1 ~ 201  
 ALL                                      Specify all points in the list

**Example:**

:LIST:CLE                              Clear the setting data of all sweep points  
 :LIST:CLE ALL                         Clear the setting data of all sweep points  
 :LIST:CLE 5                            Clear the setting data of point 5

**9.2.13.13 Sweep Point Frequency**

Used to set the sweep point frequency / set the frequency of several points starting from the n<sup>th</sup> point.

**Command Syntax:**

:LIST:FREQ [n]?  
 :LIST:FREQ [n] <f<sub>n</sub>> [, f<sub>n+1</sub>] [, f<sub>n+2</sub>]....

**Parameter:**

n	Start from the $n^{\text{th}}$ point
$f_n$	Represents the floating-point number of sweep point n
$f_{n+1}$	Represents the floating-point number of sweep point n+1
...	

**Example:**

:LIST:FREQ 20, 30, 40	Set the frequency of the first 3 points
:LIST:FREQ 1 20, 30, 40, 1k, 2k	Set the frequency of the first 5 points
:LIST:FREQ 6 20, 30, 40, 1k, 2k	Set the frequency of 6 ~ 10 points
:LIST:FREQ 25 20k	Set the frequency of the 25th point
:LIST:FREQ?	Return the frequency of all sweep points
:LIST:FREQ 4?	Return the frequency of point 4

**9.2.13.14 Sweep Point Voltage**

Used to set the sweep point measurement level / set the voltage of several points starting from the  $n^{\text{th}}$  point.

**Command Syntax:**

```
:LIST:VOLT [n]?
:LIST:VOLT [n] < $f_n$ > [,  $f_{n+1}$ ] [,  $f_{n+2}$ ]...
```

**Parameter:**

n	Start from the $n^{\text{th}}$ point
$f_n$	Represents the floating-point number of sweep point n
$f_{n+1}$	Represents the floating-point number of sweep point n+1
...	

**Example:**

:LIST:VOLT 1, 2, 3, 4, 2	Set the voltage of the first 5 points
:LIST:VOLT 6 1, 2, 3, 4, 5	Set the voltage of 6 ~ 10 points
:LIST:VOLT 25 20	Set the voltage of the 25th point
:LIST:VOLT?	Return the voltage of all sweep points
:LIST:VOLT 4?	Return the voltage of point 4

**9.2.13.15 Sweep Point Current**

Used to set the sweep point current / set the current value of several points starting from the  $n^{\text{th}}$  point.

**Command Syntax:**

```
:LIST:CURR [n]?
:LIST:CURR [n] < $f_n$ > [,  $f_{n+1}$ ] [,  $f_{n+2}$ ]...
```

**Parameter:**

n	Start from the n <sup>th</sup> point
f <sub>n</sub>	Represents the floating-point number of sweep point n
f <sub>n+1</sub>	Represents the floating-point number of sweep point n+1
...	

**Example:**

:LIST:CURREN 1m, 2m, 3m, 4m, 2m	Set the current of the first 5 points
:LIST:CURREN 6 1m, 2m, 3m, 4m, 5m	Set the current of 6 ~ 10 points
:LIST:CURREN 25 20m	Set the current of the 25th point
:LIST:CURREN?	Return the current of all sweep points
:LIST:CURREN 4?	Return the current of point 4

**9.2.13.16 Bias Voltage**

Used to set the sweep point bias voltage / set the bias voltage of several points starting from the n<sup>th</sup> point

**Command Syntax:**

```
:LIST:BIAS:VOLT [n]?
:LIST:BIAS:VOLT [n] <fn> [, fn+1] [, fn+2]...
```

**Parameter:**

n	Start from the n <sup>th</sup> point
f <sub>n</sub>	Represents the floating-point number of sweep point n
f <sub>n+1</sub>	Represents the floating-point number of sweep point n+1
...	

**Example:**

:LIST:BIAS:VOLT 1, 2, 3	Set the bias voltage of the first 3 points
:LIST:BIAS:VOLT 6 1, 2, 3, 4, 5	Set the bias voltage of 6 ~ 10 points
:LIST:BIAS:VOLT?	Return the bias voltage of all sweep points
:LIST:BIAS:VOLT 4?	Return the bias voltage of point 4

**9.2.13.17 Bias Current**

Used to set the sweep point bias current / set the bias current of several points starting from the n<sup>th</sup> point.

**Command Syntax:**

```
:LIST:BIAS:CURREN [n]?
:LIST:BIAS:CURREN [n] <fn> [, fn+1] [, fn+2]...
```

**Parameter:**

n	Start from the n <sup>th</sup> point
f <sub>n</sub>	Represents the floating-point number of sweep point n
f <sub>n+1</sub>	Represents the floating-point number of sweep point n+1
...	

**Example:**

:LIST:BIAS:CURRE 1m, 2m, 3m	Set the bias current of the first 3 points
:LIST:BIAS:CURRE 6 1m, 2m, 3m, 4m, 5m	Set the bias current of points 6 ~ 10
:LIST:BIAS:CURRE?	Return the bias current of all points
:LIST:BIAS:CURRE 4?	Return the bias current of point 4

**9.2.13.18 List Sweep Function Parameters**

Used to set the function parameters of the specified point of the list sweep.

**Command Syntax:**

```
:LIST:FUNC:IMP <n>?
:LIST:FUNC:IMP <n> <para1, para2, para3, para4>
```

**Parameter:**

n	Specifies the index of the sweep point, ranging from 1 to 201
para <sub>1</sub> , para <sub>2</sub> , para <sub>3</sub> , para <sub>4</sub>	Indicates the optional function parameter name, the values are as follows:

Parameter Name	Parameter Meaning	Parameter Name	Parameter Meaning
CP	Equivalent Parallel Capacitance	CS	Equivalent Series Capacitance
LP	Equivalent Parallel Inductance	LS	Equivalent Series Inductance
RP	Equivalent Parallel Resistance	RS	Equivalent Series Resistance
GP	Conductance	BP	Susceptance
Z	Absolute Value of Impedance	Y	Absolute Value of Admittance
D	Loss Factor	Q	Quality Factor
ZTD/DZ	∠z° Impedance Degree	ZTR/RZ	∠z Impedance Radian
YTD/DY	∠y° Admittance Degree	YTR/RY	∠y Admittance Radian
X	Reactance	RD	DC Resistance

**Example:**

:LIST:FUNC:IMP 1 CP, CS, LP, LS	Set the 4 parameter functions of point 1
:LIST:FUNC:IMP 5 CP, CS, LP, LS	Set the 4 parameter functions of point 5
:LIST:FUNC:IMP 100 CP, CS, LP, LS	Set the 4 parameter functions of the 100th point
:LIST:FUNC:IMP 1?	Return the 4-parameter functions of point 1



### 9.2.13.19 Specified Parameters

Used to set the function of list sweep specified parameters / set the function of several points starting from the  $n^{\text{th}}$  point.

#### Command Syntax:

```
:LIST:FUNC:IMP <A | B | C | D> <n>?
```

```
:LIST:FUNC:IMP <A | B | C | D> <n> <pn> [, pn+1, pn+2,...]
```

#### Parameter:

A   B   C   D	Indicate that one of the 4 parameters is specified
n	Specify the index of the sweep point, ranging from 1 to 201
p <sub>n</sub>	The function name of sweep point n, (refer to the table above)
p <sub>n+1</sub>	The function name of sweep point n+1
...	

#### Example:

:LIST:FUNC:IMP A CP, CS, LP	Set the parameter function of points 1 ~ 3 of the first parameter
:LIST:FUNC:IMP B 5 CP, CS	Set the parameter function of points 5 ~ 6 of the second parameter
:LIST:FUNC:IMP C?	Return all points' parameter functions of the third parameter
:LIST:FUNC:IMP D 11?	Return the parameter function of point 11 of the fourth parameter

### 9.2.13.20 Linear Setting of the Specified Parameter

#### Command Syntax:

```
:LIST:FUNC:LIN <A | B | C | D> <start, stop, para>
```

#### Parameter:

A   B   C   D	Indicate that one of the 4 parameters is specified
start	Specify the starting point of the setting, the value is 1 ~ 201
stop	Specify the end point of the setting, the value is 1 ~ 201
para	Function name (refer to the table above)

#### Example:

:LIST:FUNC:LIN A 1, 15, LP	Set the function of point 1 ~ 15 of the first parameter to LP
:LIST:FUNC:LIN B 5, 201, CP	Set the function of point 5 ~ 201 of the second parameter to CP
:LIST:FUNC:LIN D 3, 15, LP	Set the function of point 3 ~ 15 of the fourth parameter to LP

### 9.2.13.21 BAND Limit

Used to set the limit data at the specified point in the list sweep setting table.

#### Command Syntax:

```
:LIST:BAND <n>?
```

```
:LIST:BAND <n> OFF
```

```
:LIST:BAND <n> <A | B | C | D> <lo, hi>
```

#### Parameter:

n	Specify the index of the sweep point, ranging from 1 to 201
A   B   C   D	Indicate that one of the 4 parameters is specified
lo	The lower limit of the parameter corresponding to the specified point
hi	The upper limit of the parameter corresponding to the specified point

#### Example:

:LIST:BAND 1 OFF	Clear the limit data of all 4 parameters at point 1
:LIST:BAND 2 A, 1, 2	Set the lower limit value at point 2 of the 2 <sup>nd</sup> parameter to 1 and the upper limit value to 2
:LIST:BAND 201 D, 1.1, 2.2	Set the lower limit value at point 201 of the 4 <sup>th</sup> parameter to 1.1 and the upper limit value to 2.2
:LIST:BAND 9?	Return the upper and lower limits of all 4 parameters at point 9, lo <sub>A</sub> , hi <sub>A</sub> , lo <sub>B</sub> , hi <sub>B</sub> ...

### 9.2.13.22 Measurement Delay

Used to set the measurement delay of the sweep point / set the delay time of several points starting from the n<sup>th</sup> point.

#### Command Syntax:

```
:LIST:DEL [n]?
```

```
:LIST:DEL [n] <fn> [, fn+1] [, fn+2]...
```

#### Parameter:

n	Start from the n <sup>th</sup> point
f <sub>n</sub>	Represents the floating point number of the sweep point n
f <sub>n+1</sub>	Represents the floating point number of the sweep point n+1
...	

#### Example:

:LIST:DEL 0.01, 20m, 30m	Set the measurement delay of the first 3 points
:LIST:DEL 1m, 2m, 3m, 4m, 2m	Set the measurement delay of the first 5 points
:LIST:DEL 6 1m, 2m, 3m, 4m, 5m	Set the measurement delay of points 6 ~ 10
:LIST:DEL 25 20m	Set the measurement delay of the 25 <sup>th</sup> point
:LIST:DEL?	Return the measurement delay of all sweep points
:LIST:DEL 4?	Return the measurement delay of point 4

## 9.2.14 TRACE Subsystem Commands

### 9.2.14.1 Sweep Points

Used to set the number of LCR curve scan points.

**Command Syntax:**

```
:TSSE:POINT?
```

```
:TSSE:POINT <51 | 101 | 201 | 401 | 801>
```

**Parameter:**

51	...means scanning 51 points
101	...means scanning 101 points
201	...means scanning 201 points
401	...means scanning 401 points
801	...means scanning 801 points

**Example:**

:TSSE:POINT 51	Set LCR to scan 51 points
:TSSE:POINT 801	Set LCR to scan 801 points
:TSSE:POINT?	Return the LCR sweep points

### 9.2.14.2 Sweep Parameter Mode

Used to set the sweep parameter mode of the LCR curve.

**Command Syntax:**

```
:TSSE:MODE?
```

```
:TSSE:MODE <FREQ | VOLT | CURR | BVOL | BCUR>
```

**Parameter:** string parameter, select from list

**Example:**

:TSSE:MODE FREQ	Set the LCR sweep parameter to frequency
:TSSE:MODE CURR	Set the LCR sweep parameter to current
:TSSE:MODE BVOL	Set LCR sweep parameter as bias voltage
:TSSE:MODE?	Return the LCR sweep parameter type

### 9.2.14.3 Sweep Range

Used to set the LCR sweep range (start and stop points).

**Command Syntax:**

```
:TSSE:SWEEP?
```

```
:TSSE:SWEEP <float, float>
```

**Parameter:**

float Represents floating-point string format data, e.g. "3.14159"

**Example:**

:TSSE:SWEEP 1, 100 Set the LCR sweep start and stop point  
 :TSSE:SWEEP? Return the LCR sweep start and stop point

**9.2.14.4 Sweep Mode**

Used to set the LCR sweep mode.

**Command Syntax:**

:TSSE:SMODE?  
 :TSSE:SMODE <SEQ | STEP>

**Parameter:**

SEQ Sequential  
 STEP Single-Step

**Example:**

:TSSE:SMODE SEQ Set the LCR sweep mode to sequential mode  
 :TSSE:SMODE STEP Set the LCR sweep mode to single-step mode  
 :TSSE:SWEEP? Return the LCR sweep mode

**9.2.14.5 Format Mode**

Used to set the LCR curve format mode.

**Command Syntax:**

:TSSE:FORM?  
 :TSSE:FORM <LIN | LOGX>

**Parameter:**

LIN Linear coordinates  
 LOGX X-axis logarithm

**Example:**

:TSSE:FORM LIN Set the LCR sweep coordinate as linear coordinates  
 :TSSE:FORM LOGX Set the LCR sweep coordinate as the X axis logarithm  
 :TSSE:FORM? Return the LCR sweep coordinate mode

### 9.2.14.6 Limit Function

Used to turn on/off the LCR curve limit function.

#### Command Syntax:

```
:TSSE:LIMI?
```

```
:TSSE:LIMI <0 | 1 | OFF | ON>
```

#### Parameter:

```
0 | OFF          OFF
1 | ON           ON
```

#### Example:

```
:TSSE:LIMI 0          Turn OFF the LCR sweep limit
:TSSE:LIMI 1          Turn ON the LCR sweep limit
:TSSE:LIMI?           Return the LCR sweep limit status
```

### 9.2.14.7 LCR Sweep Function Parameters

Used to set the LCR sweep function parameters.

#### Command Syntax:

```
:TSSE:IMP [1 | 2 | 3 | 4]?
```

```
:TSSE:IMP <para1, para2, para3, para4>
```

```
:TSSE:IMP <1 | 2 | 3 | 4> <para>
```

#### Parameter:

para<sub>1</sub>, para<sub>2</sub>, para<sub>3</sub>, para<sub>4</sub> Indicates the optional function parameter name, the values are as follows:

Parameter Name	Parameter Meaning	Parameter Name	Parameter Meaning
CP	Equivalent Parallel Capacitance	CS	Equivalent Series Capacitance
LP	Equivalent Parallel Inductance	LS	Equivalent Series Inductance
RP	Equivalent Parallel Resistance	RS	Equivalent Series Resistance
GP	Conductance	BP	Susceptance
Z	Absolute Value of Impedance	Y	Absolute Value of Admittance
D	Loss Factor	Q	Quality Factor
ZTD/DZ	$\Theta_z^\circ$ Impedance Degree	ZTR/RZ	$\Theta_z$ Impedance Radian
YTD/DY	$\Theta_y^\circ$ Admittance Degree	YTR/RY	$\Theta_y$ Admittance Radian
X	Reactance	RD	DC Resistance

**Example:**

:TSSE:IMP CP, CS, LP, LS	Set all 4 parameter functions at the same time
:TSSE:IMP 1 RP	Set parameter 1 to RP
:TSSE:IMP 2 RS	Set parameter 1 to RS
:TSSE:IMP 3 Z	Set parameter 1 to Z
:TSSE:IMP 4 Y	Set parameter 1 to Y
:TSSE:IMP 1?	Return parameter 1 function
:TSSE:IMP 2?	Return parameter 2 function
:TSSE:IMP 3?	Return parameter 3 function
:TSSE:IMP 4?	Return parameter 4 function
:TSSE:IMP?	Return the functions of all 4 parameters

**9.2.14.8 Auto-Scaling**

Used to configure the LCR auto-scaling function.

**Command Syntax:**

```
:TSSE:SCAL?
:TSSE:SCAL <AUTO | HOLD>
```

**Parameter:**

AUTO	AUTO mode
HOLD	HOLD mode

**Example:**

:TSSE:SCAL AUTO	Set LCR auto-scaling to auto
:TSSE:SCAL HOLD	Set LCR auto-scaling to hold
:TSSE:SCAL?	Return LCR scanning auto-scaling status

**9.2.14.9 ABCD Vertical Coordinate Range**

Used to set the highest value of LCR curve coordinates.

**Command Syntax:**

```
:TSSE:<A | B | C | D>?
:TSSE:<A | B | C | D> <min, max>
```

**Parameter:**

A   B   C   D	Indicate that one of the 4 parameters is specified
min	Lower limit value of coordinate range
max	Upper limit value of coordinate range

**Example:**

:TSSE:A 10, 1000	Set LCR scan parameter A vertical coordinate range to 10 ~ 1000
:TSSE:B 10, 1000	Set LCR scan parameter B vertical coordinate range to 10 ~ 1000
:TSSE:C 10, 1000	Set LCR scan parameter C vertical coordinate range to 10 ~ 1000
:TSSE:D 10, 1000	Set LCR scan parameter D vertical coordinate range to 10 ~ 1000
TSSE:A?	Return LCR scan parameter A coordinate range
TSSE:B?	Return LCR scan parameter B coordinate range
TSSE:C?	Return LCR scan parameter C coordinate range
TSSE:D?	Return LCR scan parameter D coordinate range

**9.2.14.10 Split Screen**

Used to configure the LCR curve split screen setting.

**Command Syntax:**

```
:TSSE:SPLI?
:TSSE:SPLI <1 | 2 | 4>
```

**Parameter:**

1	No split screen / one screen
2	Split screen in two
4	Split screen in four

**Example:**

:TSSE:SPLI 1	Set LCR scan split screen function to one screen
:TSSE:SPLI 2	Set LCR scan split screen function to a two-way split
:TSSE:SPLI 4	Set LCR scan split screen function to a four-way split
:TSSE:SPLI?	Return LCR scan split screen function status

**9.2.14.11 Curve Display**

Turn on/off LCR curve display; supports configuring up to 4 curve displays at the same time.

**Command Syntax:**

```
:TSSE:SW?
:TSSE:SW [1 | 2 | 3 | 4] <0 | 1 | 2> [, 0 | 1 | 2]...
```

**Parameter:**

SW [1   2   3   4]	...specifies which curve to start from (omitting this number automatically sets it to start at the first curve)
0	OFF
1	ON
2	Maintain; omits the specified curve after running through SW

**Example:**

:TSSE:SW 0, 0, 0, 0	Set LCR scan to not display any of the 4 curves
:TSSE:SW 0, 1, 0, 1	Set LCR scan to turn on only the 2 <sup>nd</sup> and 4 <sup>th</sup> curves
:TSSE:SW 2, 1, 2, 1	Set LCR scan to disable 1 <sup>st</sup> and 3 <sup>rd</sup> curve displays
:TSSE:SW 4 0	Set LCR scan to turn off the 4 <sup>th</sup> curve display
:TSSE:SW?	Return LCR scan curve display status

## 9.2.15 Handler Subsystem Commands

### 9.2.15.1 Handler Mode

Used to set the LCR handler mode.

**Command Syntax:**

```
:HAND:STAT?
:HAND:STAT <0 | 1 | 2 | OFF | ON | BUS>
```

**Parameter:**

0   OFF	Default
1   ON	Custom
2   BUS	BUS Control

**Example:**

:HAND:STAT 0	Set the handler mode to default
:HAND:STAT OFF	Set the handler mode to default
:HAND:STAT 1	Set the handler mode to custom
:HAND:STAT ON	Set the handler mode to custom
:HAND:STAT BUS	Set the handler mode to BUS

### 9.2.15.2 Custom Output

Used to control the LCR Handler custom output.

**Command Syntax:**

```
:HAND:STAT:OFLO <...>
:HAND:STAT:OFHI <...>
:HAND:STAT:LVLO <...>
:HAND:STAT:LVHI <...>
:HAND:STAT:PUHI <...>
:HAND:STAT:PULO <...>
```



**Parameter:**

<...> is a list format, e.g. 1, 2, 4, 7, 14, 24, etc., corresponding to the table position displayed by the instrument.

**Example:**

:HAND:STAT:OFLO 1, 3, 5, 9	Set the index function of 1, 3, 5, 9 to a constant low level
:HAND:STAT:OFHI 1, 3, 5, 9	Set the index function of 1, 3, 5, 9 to a constant high level
:HAND:STAT:LVLO 1, 3, 5, 9	Set the index function of 1, 3, 5, 9 to an active low level
:HAND:STAT:LVHI 1, 3, 5, 9	Set the index function of 1, 3, 5, 9 to an active high level
:HAND:STAT:PUHI 1, 3, 5, 9	Set the index function of 1, 3, 5, 9 to an active high pulse
:HAND:STAT:PULO 1, 3, 5, 9	Set the index function of 1, 3, 5, 9 to an active low pulse

**9.2.15.3 Bus Output**

Used to control the LCR Handler bus output.

**Command Syntax:**

```
:HAND:OUTP:LVHI <...>
:HAND:OUTP:LVLO <...>
```

**Parameter:**

<...> is a list format, e.g. 1, 2, 4, 7, 14, 24, etc., corresponding to the table position displayed by the instrument.

**Example:**

:HAND:LVHI:LVHI 1, 3, 5, 9	Set 1, 3, 5, 9 to high level output in bus mode
:HAND:LVLO:LVLO 1, 3, 5, 9	Set 1, 3, 5, 9 to low level output in bus mode

**9.2.16 FETCh? Subsystem Commands****9.2.16.1 General Query: Measurement Results**

Return the result of the most recent measurement in the currently selected measurement mode.

**Command Syntax:**

```
:FETC? Return the measurement result of the parameter
```

**Example:**

Test Page										
LCR Meter	Component Testing	<p>Parameter 1 result, parameter 2 result, parameter 3 result, parameter 4 result, sorting results.</p> <p><b>Example:</b> 1.12345E2, 1.23456E-2, 1.11023E2, -1.12345E2,1</p> <p>The sorting results take the following values:</p> <table border="1"> <thead> <tr> <th>Sorting Result</th> <th>Description</th> </tr> </thead> <tbody> <tr> <td>0</td> <td>BIN OUT</td> </tr> <tr> <td>1 ~ 10</td> <td>BIN 1 ~ 10</td> </tr> </tbody> </table> <p><b>Note:</b> The &lt;BIN&gt; data will only be displayed when the instrument's comparison function is turned ON.</p>	Sorting Result	Description	0	BIN OUT	1 ~ 10	BIN 1 ~ 10		
	Sorting Result	Description								
	0	BIN OUT								
1 ~ 10	BIN 1 ~ 10									
List Sweep	<p>Clike index, parameter 1 result, parameter 2 result, parameter 3 result, parameter 4 result, comparison results:</p> <p><b>Example:</b> 2, 1.12345E2, 1.23456E-2, 1.11023E2, -1.12345E2, 1</p> <p>The comparison results take the following values:</p> <table border="1"> <thead> <tr> <th>Comparison Results</th> <th>Description</th> </tr> </thead> <tbody> <tr> <td>0</td> <td>No Comparison</td> </tr> <tr> <td>1</td> <td>PASS</td> </tr> <tr> <td>Other</td> <td>FAIL</td> </tr> </tbody> </table>	Comparison Results	Description	0	No Comparison	1	PASS	Other	FAIL	
Comparison Results	Description									
0	No Comparison									
1	PASS									
Other	FAIL									
Trace Sweep	<p>Clike index, parameter 1 result, parameter 2 result, parameter 3 result, parameter 4 result,</p> <p><b>Example:</b> 2, 1.12345E2, 1.23456E-2, 1.11023E2, -1.12345E2</p>									
Transformer	Single Test	<p>Serial number index, parameter name, parameter result comparison result,</p> <p><b>Example:</b> 2, lx, 1.12345E2, 1</p> <p>The comparison results take the following values:</p> <table border="1"> <thead> <tr> <th>Comparison Results</th> <th>Description</th> </tr> </thead> <tbody> <tr> <td>0</td> <td>No Comparison</td> </tr> <tr> <td>1</td> <td>PASS</td> </tr> <tr> <td>Other</td> <td>FAIL</td> </tr> </tbody> </table>	Comparison Results	Description	0	No Comparison	1	PASS	Other	FAIL
	Comparison Results	Description								
0	No Comparison									
1	PASS									
Other	FAIL									
Scan										

**9.2.16.2 Query Measurement Level Monitoring Results****Command Syntax:**

:FETC:SMON:VAC?                      Return the voltage monitoring result

:FETC:SMON:IAC?                      Return the current monitoring result

### 9.2.16.3 Automatic Return of Data

Used to configure the AUTO FETCh setting (this state is not saved after power-off).

#### Command Syntax:

:FETC:AUTO?

:FETC:AUTO <0 | 1 | 2 | 3 | OFF | ON>

#### Parameter:

0   OFF	OFF
1   ON	ON (.i.e. trigger the end of the test to automatically return to the test results of this measurement; the result format is the same as the above FETC?)
2	Trigger the end of the test results to return to the end of the status, do not directly return the results; <ul style="list-style-type: none"> <li>return "Trig Eom\n" indicates the end of the test</li> <li>return "Trig Pause\n" indicates that the test is paused (transformer paging scanning application)</li> </ul>
3	For transformer scanning: automatically return the measured parameters of the ASCII data format.

#### Example:

:FETC:AUTO 0	Turn OFF the AUTO FETCh function
:FETC:AUTO 1	Turn ON the AUTO FETCh function (automatically return measurement results after end of test)
:FETC:AUTO 2	Set the AUTO FETCh function to return to end state after end of test; do not return test results
:FETC:AUTO?	Return the AUTO FETCh function's status

### 9.2.16.4 List Sweep Results

Used to fetch the list sweep results.

#### Command Syntax:

:FETC:LIST:PARA <1 | 2 | 3 | 4>?

:FETC:LIST:PT <1 ~ 201>?

:FETC:LIST:COMP [1 ~ 201]?

:FETC:LIST [1 ~ 201]?

#### Parameter:

PARA <1   2   3   4>	Measurement result of the specified parameter in list sweep
PT <1 ~ 201>	Measurement results of all parameters at the specified point
COMP [1 ~ 201]	Comparison results at the specified point in the list
LIST [1 ~ 201]	Results of all parameters at all points within this list

**Example:**

:FETC:LIST:PARA 1?	Return the measurement result of list sweep parameter 1
:FETC:LIST:PARA 3?	Return the measurement result of the list sweep parameter 3
:FETC:LIST:PT 5?	Return the result of all parameters at point 5
:FETC:LIST:COMP?	Return the comparison results at all points in the list
:FETC:LIST:COMP 4?	Return the comparison result of the 4 <sup>th</sup> item in the list
:FETC:LIST?	Returns the measurement results of all 4 parameters at all points in the list e.g. P1.1, P1.2, P1.3, P1.4, P1.cmp, P2.1...
:FETC:LIST 3?	Return the list at point 3 of the 4 parameters and the results of the comparison

**Note:** Separate multiple pieces of data using the comma. If there is a parameter display that is turned off, then the separator in the middle of the data content is no data.

**9.2.16.5 Trace Sweep Results**

Used to fetch the trace sweep results.

**Command Syntax:**

```
:FETC:TRACE:X [1 ~ 801]?
:FETC:TRACE:Y <1 | 2 | 3 | 4>?
:FETC:TRACE:PT <1 ~ 801>?
:FETC:TRACE:MARK?
:FETC:TRACE:YMAX <1 | 2 | 3 | 4>?
:FETC:TRACE:YMIN <1 | 2 | 3 | 4>?
```

**Parameter:**

X [1 ~ 801]	The abscissa of the trace sweep
Y <1   2   3   4>	The measurement result of the specified curve (all points)
PT <1 ~ 801>	The measurement result at the specified point (x, y <sub>1</sub> , y <sub>2</sub> , y <sub>3</sub> , y <sub>4</sub> )
MARK	The measurement results at the cursor of all traces (x, y <sub>1</sub> , y <sub>2</sub> , y <sub>3</sub> , y <sub>4</sub> )
YMAX <1   2   3   4>	The maximum value (x, y) of the specified curve
YMIN <1   2   3   4>	The minimum value (x, y) of the specified curve

**Example:**

:FETC:TRACE:X?	Return a list of all the abscissa data of the trace sweep
:FETC:TRACE:X 5?	Return the abscissa of point 5 of the trace sweep
:FETC:TRACE:Y 2?	Return the measurement result of trace curve 2
:FETC:TRACE:PT 5?	Return the result of all curves at point 5
:FETC:TRACE:MARK?	Return the result at the curve cursor (x, y <sub>1</sub> , y <sub>2</sub> , y <sub>3</sub> , y <sub>4</sub> )
:FETC:TRACE:YMAX 1?	Return the maximum value of curve 1 (x, y)
:FETC:TRACE:YMIN 3?	Return the minimum value of curve 3 (x, y)

## 9.2.16.6 Transformer Single Group Result

Used to fetch the transformer's single group test result.

### Command Syntax:

```
:FETC:TRT <0 ~ 12>
```

```
:FETC:TRTL <1 ~ 12>
```

### Parameter:

TRT 0	At all points
TRT <1 ~ 12>	At specified point
TRTL <1 ~ 12>	From point 1 to specified point

### Example:

:FETCh:TRT 0	Return measurement data at all points
:FETCh:TRT 1	Return measurement data at point 1
:FETCh:TRT 12	Return measurement data at point 12
:FETCh:TRTL 5	Return measurement data at points 1 ~ 5
:FETCh:TRTL 11	Return measurement data at points 1 ~ 11

**Note:** The return data format is: <pt, paraStr, val, comp>. The format of multi-point return data is multiple sets of single-point return data separated by a semicolon.

## 9.2.17 CORRection Subsystem Commands

### 9.2.17.1 Execute Open-Circuit Correction

Used to execute preset measurement point open-circuit correction.

### Command Syntax:

```
:CORR:OPEN [ACK]
```

### Example:

:CORR:OPEN	Perform the open-circuit correction on the preset point, no return
:CORR:OPEN ACK	Perform the open-circuit correction on the preset point

Return 1 for success and 0 for failure.

### 9.2.17.2 Open-Circuit Correction Function

Used to turn on/off the open-circuit correction function.

### Command Syntax:

```
:CORR:OPEN:STAT?
```

```
:CORR:OPEN:STAT <0 | 1 | OFF | ON>
```

**Parameter:**

0   OFF	OFF
1   ON	ON

**Example:**

:CORR:OPEN:STAT 0	Turn OFF the open-circuit correction function
:CORR:OPEN:STAT 1	Turn ON the open-circuit correction function
:CORR:OPEN:STAT?	Return the open-circuit correction function status

**9.2.17.3 Execute Short-Circuit Correction**

Used to execute preset measurement point short-circuit correction.

**Command Syntax:**

```
:CORR:SHOR [ACK]
```

**Example:**

:CORR:SHOR	Perform short-circuit correction on preset point, no return
:CORR:SHOR ACK	Perform short-circuit correction on preset point

Return 1 for success and 0 for failure.

**9.2.17.4 Short-Circuit Correction Function**

Used to turn on/off the short-circuit correction function.

**Command Syntax:**

```
:CORR:SHOR:STAT?
:CORR:SHOR:STAT <0 | 1 | OFF | ON>
```

**Parameter:**

0   OFF	OFF
1   ON	ON

**Example:**

:CORR:SHOR:STAT 0	Turn OFF the short-circuit correction function
:CORR:SHOR:STAT 1	Turn ON the short-circuit correction function
:CORR:SHOR:STAT?	Return the short-circuit correction function status

**9.2.17.5 Load Correction Function**

Used to turn on/off the load correction function.

**Command Syntax:**

```
:CORR:LOAD:STAT?
:CORR:LOAD:STAT <0 | 1 | OFF | ON>
```

**Parameter:**

0 | OFF                      OFF  
 1 | ON                        ON

**Example:**

:CORR:LOAD:STAT 0            Turn OFF the load correction function  
 :CORR:LOAD:STAT 1            Turn ON the load correction function  
 :CORR:LOAD:STAT?            Return the load correction function status

**9.2.17.6 Load Type**

Used to set the measured combination parameter function for load correction.

**Command Syntax:**

:CORR:LOAD:TYPE?  
 :CORR:LOAD:TYPE <para>

**Parameter:**

para                              Indicates the optional function parameter name; the values are as follows:

Parameter Name	Parameter Meaning
LSRS	LS-RS
LSQ	LS-Q
CPD	CP-D

**Example:**

:CORR:LOAD:TYPE LSRS        Set the load type to LS-RS  
 :CORR:LOAD:TYPE LSQ        Set the load type to LS-Q  
 :CORR:LOAD:TYPE CPD        Set the load type to CP-D  
 :CORR:LOAD:TYPE?            Return the load type

**9.2.17.7 Cable Length**

Used to set the correction cable length of the instrument.

**Command Syntax:**

:CORR:LENG?  
 :CORR:LENG <0|1>

**Parameter:**

0                                0 m  
 1                                1 m

**Example:**

:CORR:LENG 0                   Set the cable length to 0 meter  
 :CORR:LENG 1                   Set the cable length to 1 meter  
 :CORR:LENG?                   Return the cable length

**9.2.17.8 Clear User Correction Data****Command Syntax:**

:CORR:CLE [pt]

**Parameter:**

[pt]                           indicating the specified correction point index; value range of 1 ~ 10

**Example:**

:CORR:CLE                   Clear all user correction data  
 :CORR:CLE 1                Clear the correction data of point 1 calibrated by the user  
 :CORR:CLE 4                Clear the correction data of point 4 calibrated by the user  
 :CORR:CLE 10               Clear the correction data of point 10 calibrated by the user

**9.2.17.9 Query the User Correction Data****Command Syntax:**

:CORR[:USE]:DATA [n]?

**Parameter:**

n                            The value is 1 ~ 10, which indicates the index of n<sup>th</sup> of dot frequency clearing point

**Example:**

:CORR:DATA?                Return the open-circuit correction value, short-circuit correction value, load correction value of all set points:  
 <open<sub>1</sub> A>, <open<sub>1</sub> B>, <short<sub>1</sub> A>, <short<sub>1</sub> B>, <load<sub>1</sub> A>, <load<sub>1</sub> B>, <open<sub>2</sub> A>, <open<sub>2</sub> B>, <short<sub>2</sub> A>, <short<sub>2</sub> B>, <load<sub>2</sub> A>, <load<sub>2</sub> B>...

:CORR:DATA 1?              Return the correction data of point 1:  
 <point index (1)>, <frequency>, <open A>, <open B>, <short A>, <short B>, <load A>, <load B>, <reference A>, <reference B>

:CORR:DATA 2?              Return the correction data of point 2  
 <point index (2)>, <frequency>, <open A>, <open B>, <short A>, <short B>, <load A>, <load B>, <reference A>, <reference B>

:CORR:DATA 3?              Return the correction data of point 3:  
 <point index (3)>, <frequency>, <open A>, <open B>, <short A>, <short B>, <load A>, <load B>, <reference A>, <reference B>



:CORR:DATA 10?                      Return the correction data of point 10:  
    <point index (10)>, <frequency>, <open A>, <open B>, <short A>, <short B>, <load A>,  
    <load B>, <reference A>, <reference B>

### 9.2.17.10 Query the User Correction Time

#### Command Syntax:

:CORR:DATE <LAST | OPEN | SHORT | DCR | DCROPEN | DCRSHORT>

:CORR:DATE <n> <OPEN | SHORT | LOAD>

#### Parameter:

DATE <n>	n indicates the n <sup>th</sup> frequency point
LAST	Indicates the time of the last clearing operation
OPEN   SHORT   LOAD	Represents open-circuit correction, short-circuit correction, and load correction, respectively
DCR   DCROPEN   DCRSHORT	Represents DCR, DCR open-circuit correction, and DCR short-circuit correction, respectively

#### Example:

:CORR:DATE LAST	Return the time of the last correction
:CORR:DATE OPEN	Return the time of the full frequency open-circuit correction
:CORR:DATE SHORT	Return the time of the full-frequency short-circuit correction
:CORR:DATE DCR	Return the time of the last DCR correction
:CORR:DATE DCROPEN	Return the time of the DCR open-circuit correction
:CORR:DATE DCRSHORT	Return the time of the DCR short-circuit correction
:CORR:DATE 1 LAST	Return the time of the last correction at frequency point 1
:CORR:DATE 2 OPEN	Return the time of the open-circuit correction at frequency point 2
:CORR:DATE 3 SHORT	Return the time of the short-circuit correction at frequency point 3
:CORR:DATE 10 LOAD	Return the time of the load correction at frequency point 10

**Note:** The format of the returned data is "yyyy-MM-dd hh:mm:ss", and a return of "----" indicates that the date is invalid; that is, the correction has not been performed.

### 9.2.17.11 Specified Frequency Point

Used to turn on/off the the specified frequency point.

#### Command Syntax:

:CORR:SPOT <n>:STAT?

:CORR:SPOT <n>:STAT <0 | 1 | OFF | ON>

**Parameter:**

n	Frequency point index, value 1 ~ 10
0   OFF	OFF
1   ON	ON

**Example:**

:CORR:SPOT 1:STAT 0	Turn OFF frequency point 1
:CORR:SPOT 3:STAT 1	Turn ON frequency point 3
:CORR:SPOT 10:STAT?	Return the status of frequency point 10

**9.2.17.12 Measurement Frequency**

Used to specify the measurement frequency of the frequency point.

**Command Syntax:**

```
:CORR:SPOT <n>:FREQ?
:CORR:SPOT <n>:FREQ <float | MIN | MAX>
```

**Parameter:**

float	Represents the floating-point data
MIN	Set the minimum possible value
MAX	Set the maximum possible value

**Example:**

:CORR:SPOT 1:FREQ 1200	Set the frequency to 1200 Hz
:CORR:SPOT 2:FREQ 1100HZ	Set the frequency to 1100 Hz
:CORR:SPOT 3:FREQ 1.2K	Set the frequency to 1200 Hz
:CORR:SPOT 4:FREQ?	Return the frequency of frequency point 4

**9.2.17.13 Open-Circuit Correction at Specific Frequency**

Used to execute an open-circuit correction at specific frequency points (frequency 1, frequency 2, etc.).

**Command Syntax:**

```
:CORR:SPOT <n>:OPEN
```

**Example:**

:CORR:SPOT 1:OPEN	Perform open-circuit correction at frequency point 1
:CORR:SPOT 2:OPEN	Perform open-circuit correction at frequency point 2
:CORR:SPOT 10:OPEN	Perform open-circuit correction at frequency point 10

Return 1 for success and 0 for failure.

### 9.2.17.14 Short-Circuit Correction at Specific Frequency

Used to execute a short-circuit correction at specific frequency points (frequency 1, frequency 2, etc.).

**Command Syntax:**

```
:CORR:SPOT <n>:SHOR
```

**Example:**

```
:CORR:SPOT 1:SHOR          Perform short-circuit correction at frequency point 1
:CORR:SPOT 2:SHOR          Perform short-circuit correction at frequency point 2
:CORR:SPOT 10:SHOR         Perform short-circuit correction at frequency point 10
```

Return 1 for success and 0 for failure.

### 9.2.17.15 Reference Values for Load Correction at Specific Frequency

Used to set the load correction reference values for specific frequency points (frequency 1, frequency 2, etc.).

**Command Syntax:**

```
:CORR:SPOT <n>:LOAD:STAN?
:CORR:SPOT <n>:LOAD:STAN <refA, refB>
```

**Parameter:**

```
refA          Represents the floating point data of reference A
refB          Represents the floating point data of reference B
```

**Example:**

```
:CORR:SPOT 1:LOAD:STAN 1.1, 1.2   The reference value for load correction at frequency point 1
:CORR:SPOT 2:LOAD:STAN 1.1, 1.2   The reference value for load correction at frequency point 2
:CORR:SPOT 10:LOAD:STAN?          Return the reference value for load correction of frequency point 10
```

### 9.2.17.16 Load Correction at Specific Frequency

Used to execute a load correction at specific frequency points (frequency 1, frequency 2, etc.).

**Command Syntax:**

```
:CORR:SPOT <n>:LOAD
```

**Example:**

```
:CORR:SPOT 1:LOAD          Perform load correction at frequency point 1
:CORR:SPOT 2:LOAD          Perform load correction at frequency point 2
:CORR:SPOT 10:LOAD         Perform load correction at frequency point 10
```

Return 1 for success and 0 for failure.

## 9.2.18 Mass MEMory Subsystem Commands

The Mass MEMory subsystem commands are used to save and load files.

### 9.2.18.1 Load

Used to load saved files.

#### Command Syntax:

```
:MMEM:LOAD?
```

```
:MMEM:LOAD <file>
```

#### Parameter:

file Specifies the path of the file to be loaded, relatively complete file path or the index number of the internal file fixed file, ranging from 1 to 50

The corresponding relationship between the index number and the file is as follows:

Index Number	LCR Mode	Transformer Single-Group Mode	Transformer Scan Mode
1 ~ 50	LCR.sda/LCR2.sda... in the root directory of internal files	TRT.trt/TRT2.trt... in the root directory of internal files	ST2840.t40/ST28402.t40... in the root directory of internal files

#### Example:

```
:MMEM:LOAD 1           Load the file with the path LCR.sta
:MMEM:LOAD 9           Load the file with the path LCR9.sta
:MMEM:LOAD sss.sta     Load the file with the path files/sss.sta
:MMEM:LOAD files/sss.sta Load the file with the path files/sss.sta
:MMEM:LOAD usb/sss.sta Load the file with the path usb/sss.sta
:MMEM:LOAD?           Return the path name of the file to load
```

### 9.2.18.2 Store

Used to save the current instrument settings to a file.

#### Command Syntax:

```
:MMEM:STOR <n> [, file]
```

#### Parameter:

n For use with the default saved file naming  
file Specifies the name of the file to save

The corresponding relationship between the index number and the default file is as follows:

Index No.	LCR Mode	Transformer Single-Group Mode	Transformer Scan Mode
1 ~ 50	LCR.sda/LCR2.sda... in the root directory of internal files	TRT.trt/TRT2.trt... in the root directory of internal files	ST2840.t40/ST28402.t40... in the root directory of internal files

**Example:**

```
:MMEM:STOR 1           Save LCR.sta file (in LCR mode)
:MMEM:STOR 9           Save LCR9.sta file (in LCR mode)
:MMEM:STOR 5, sss.sta  Save a file with the path sss.sta
:MMEM:STOR 5, files/sss.sta  Save a file with the path files/sss.sta
:MMEM:STOR 5, usb/sss.sta  Save a file with the path usb/sss.sta
```

## 9.2.19 TRAN Subsystem Commands

The TRAN subsystem commands are mainly used to set transformer parameters, such as turn-ratio, primary inductance, leakage inductance, stray capacitance, impedance, AC impedance, DC resistance, working mode and limits of each parameter.

### 9.2.19.1 Test Mode

Used to set the single group test mode.

**Command Syntax:**

```
:TRT:MODE?
:TRT:MODE<SEQ | STEP>
```

**Parameter:**

```
SEQ           Sequential
STEP          Single-Step
```

**Example:**

```
:TRT:MODE SEQ      Set to sequential mode
:TRT:MODE STEP     Set to single-step mode
:TRT:MODE?         Return the single group test mode
```

### 9.2.19.2 Single-Group Comparison Function

Used to turn on/off the single-group comparison function.

**Command Syntax:**

```
:TRT:COMP?
:TRT:COMP <0 | 1 | OFF | ON>
```

**Parameter:**

OFF | 0                      OFF  
 ON | 1                        ON

**Example:**

:TRT:COMP 0                      Turn OFF the comparison function  
 :TRT:COMP 1                      Turn ON the comparator function  
 :TRT:COMP?                      Return the single-group comparison function status

**9.2.19.3 Function Parameters**

Used to set the function parameters of a single group of specified points.

**Command Syntax:**

:TRT:FUNC <n>?  
 :TRT:FUNC <n> <para>

**Parameter:**

n                                      Specifies the index of the scan point, ranging from 1 to 12  
 para                                    Indicates the optional function parameter name, the values are as follows:

Parameter Name	Parameter Meaning	Parameter Name	Parameter Meaning
CP	Equivalent Parallel Capacitance	CS	Equivalent Series Capacitance
LP	Equivalent Parallel Inductance	LS	Equivalent Series Inductance
RP	Equivalent Parallel Resistance	RS	Equivalent Series Resistance
D	Loss Factor	Q	Quality Factor
ZX	Absolute Value of Impedance	RD	DC Resistance
LK	Leakage Inductance	DZ	Impedance Degree
NS	Primary Turn	NSNP	Primary Turn / Secondary Turn
NP	Secondary Turn	NPNS	Secondary Turn / Primary Turn

**Example:**

:TRT:FUNC 1 CP                      Set the function parameter of point 1 to CP  
 :TRT:FUNC 5 NS                      Set the function parameter of point 5 to NS  
 :TRT:FUNC 12 NSNP                      Set the function parameter of point 12 to NSNP  
 :TRT:FUNC 1?                        Return the function parameters of point 1

### 9.2.19.4 Frequency

Used to set the sweep point frequency.

**Command Syntax:**

```
:TRT:FREQ <n>?
:TRT:FREQ <n> <fn>
```

**Parameter:**

n	Start from the n <sup>th</sup> point
f <sub>n</sub>	Represents the floating-point number of sweep point n

**Example:**

:TRT:FREQ 1 20	Set the frequency of point 1 to 20
:TRT:FREQ 6 1k	Set the frequency of point 6 to 1k
:TRT:FREQ 12 20k	Set the frequency of point 12 to 20k
:TRT:FREQ 4?	Return the frequency of point 4

### 9.2.19.5 Level

Used to set the measurement level (voltage) of the sweep point.

**Command Syntax:**

```
:TRT:LEV <n>?
:TRT:LEV <n> <fn>
```

**Parameter:**

n	Specifies the index of the sweep point, ranging from 1 to 12
f <sub>n</sub>	Represents the floating-point number of sweep point n

**Example:**

:TRT:LEV 1 0.5	Set the voltage of point 1 to 0.5
:TRT:LEV 6 2.5	Set the voltage of point 6 to 2.5
:TRT:LEV 4?	Return the voltage of point 4

### 9.2.19.6 Bias Voltage

Used to set the bias voltage of the sweep point.

**Command Syntax:**

```
:TRT:BIAS:VOLT <n>?
:TRT:BIAS:VOLT <n> <fn>
```

**Parameter:**

n	Specifies the index of the sweep point, ranging from 1 to 12
f <sub>n</sub>	Represents the floating-point number of sweep point n

**Example:**

:TRT:BIAS:VOLT 1 1.2           Set the bias voltage of point 1 to 1.2  
:TRT:BIAS:VOLT 6 1.5           Set the bias voltage of point 6 to 1.5  
:TRT:BIAS:VOLT 4?           Return the bias voltage of point 4

**9.2.19.7 Bias Current**

Used to set the bias current of the sweep point.

**Command Syntax:**

:TRT:BIAS:CURR <n>?  
:TRT:BIAS:CURR <n> <f<sub>n</sub>>

**Parameter:**

n                               Specifies the index of the sweep point, ranging from 1 to 12  
f<sub>n</sub>                              Represents the floating-point number of sweep point n

**Example:**

:TRT:BIAS:CURR 1 1           Set the bias current of point 1 to 1  
:TRT:BIAS:CURR 6 5           Set the bias current of point 6 to 5  
:TRT:BIAS:CURR 4?           Return the bias current of point 4

**9.2.19.8 Turn Ratio Relative Reference Value**

Used to set the relative reference value under the turn ratio function.

**Command Syntax:**

:TRT:TURN <n>?  
:TRT:TURN <n> <f<sub>n</sub>>

**Parameter:**

n                               Specifies the index of the sweep point, ranging from 1 to 12  
f<sub>n</sub>                              Represents the floating-point number of sweep point n

**Example:**

:TRT:TURN 1 1           Set the relative reference value of point 1 to 1 turn  
:TRT:TURN 6 10           Set the relative reference value of point 6 to 10 turns  
:TRT:TURN 4?           Return the relative reference value of point 4



### 9.2.19.9 Deviation

Used to set the deviation comparison mode of the instrument.

#### Command Syntax:

```
:TRT:DEV <n>?
```

```
:TRT:DEV <n> <ABS | PER | OFF>
```

#### Parameter:

ABS	$\Delta$ Absolute Deviation
PER	$\Delta\%$ Percent Deviation
OFF	OFF

#### Example:

:TRT:DEV 1 ABS	Set the comparison mode of point 1 to absolute deviation
:TRT:DEV 2 PER	Set the comparison mode of point 2 to percent deviation
:TRT:DEV 3 OFF	Turn OFF the deviation of the comparison function at point 3
:TRT:DEV 2?	Return the deviation mode of comparison function at point 2

### 9.2.19.10 Nominal Value

Used to set the nominal value of the deviation.

#### Command Syntax:

```
:TRT:NOM <n>?
```

```
:TRT:NOM <n> <fn>
```

#### Parameter:

n	Specifies the index of the sweep point, ranging from 1 to 12
f <sub>n</sub>	Represents the floating-point number of sweep point n

#### Example:

:TRT:NOM 1 10.2	Set the comparison nominal value of point 1 to 10.2
:TRT:NOM 2 2.3	Set the comparison nominal value of point 2 to 2.3
:TRT:NOM 3 62.5	Turn OFF the comparison nominal value of point 3 to 62.5
:TRT:NOM 2?	Return the comparison nominal value of point 2.

### 9.2.19.11 Lower Limit

Used to set the instrument's lower limit for the comparison function.

#### Command Syntax:

```
:TRT:LOW <n>?
```

```
:TRT:LOW <n> <fn>
```

**Parameter:**

n	Specifies the index of the sweep point, ranging from 1 to 12
f <sub>n</sub>	Represents the floating-point number of sweep point n

**Example:**

:TRT:LOW 1 10.2	Set the comparison lower limit of point 1 to 10.2
:TRT:LOW 2 2.3	Set the comparison lower limit of point 2 to 2.3
:TRT:LOW 3 62.5	Turn OFF the comparison lower limit of point 3 to 62.5
:TRT:LOW 2?	Return the comparison lower limit of point 2

**9.2.19.12 Upper Limit**

Used to set the instrument's upper limit for the comparison function.

**Command Syntax:**

```
:TRT:HIGH <n>?
:TRT:HIGH <n> <fn>
```

**Parameter:**

n	Specifies the index of the sweep point, ranging from 1 to 12
f <sub>n</sub>	Represents the floating-point number of sweep point n

**Example:**

:TRT:HIGH 1 10.2	Set the comparison upper limit of point 1
:TRT:HIGH 2 2.3	Set the comparison upper limit of point 2
:TRT:HIGH 3 62.5	Turn OFF the comparison upper limit of point 3
:TRT:HIGH 2?	Return the comparison upper limit of point 2

**9.2.19.13 Average**

Used to set the average number of sweep points.

**Command Syntax:**

```
:TRT:AVG <n>?
:TRT:AVG <n> <intn>
```

**Parameter:**

n	Specifies the index of the sweep point, ranging from 1 to 12
int <sub>n</sub>	The average number of sweep point n, ranging from 1 to 255

**Example:**

:TRT:AVG 1 1	Set the average number of point 1 to 1
:TRT:AVG 2 5	Set the average number of point 2 to 5
:TRT:AVG 6 20	Set the average number of point 6 to 20
:TRT:AVG 4?	Return the average number of point 4

### 9.2.19.14 Delay

Used to set the sweep points' measurement delay.

**Command Syntax:**

```
:TRT:DEL <n>?
```

```
:TRT:DEL <n> <fn>
```

**Parameter:**

n	Specifies the index of the sweep point, ranging from 1 to 12
f <sub>n</sub>	Represents the floating-point number of the sweep point

**Example:**

:TRT:DEL 1 0.01	Set the measurement delay of point 1
:TRT:DEL 2 3m	Set the measurement delay of point 2
:TRT:DEL 6 5m	Set the measurement delay of point 3
:TRT:DEL 4?	Return the measurement delay of point 4

### 9.2.19.15 Include/Exclude Sweep Point

Used to turn on/off measurement of any particular sweep point.

**Command Syntax:**

```
:TRT:STAT <n>?
```

```
:TRT:STAT <n> <0 | 1 | OFF | ON>
```

**Parameter:**

n	Specifies the index of the sweep point, ranging from 1 to 12
OFF   0	OFF
ON   1	ON

**Example:**

:TRT:STAT 2 0	Turn OFF the measurement function at point 2
:TRT:STAT 8 1	Turn ON the measurement function at point 8
:TRT:STAT 12?	Return the measurement function status at point 12

## 9.2.20 TRS Transformer Scan Subsystem Commands

### 9.2.20.1 Parameter Auto Reset

Used to turn on/off Auto Reset State for all parameters.

**Command Syntax:**

```
:TRS:DATAALLSW <0 | 1 | OFF | ON>
```

```
:TRS:DATAALLSW?
```

**Parameter:**

0 | OFF                                    OFF (parameters involved in the measurement will have a return value)  
 1 | ON                                    ON (all test data will be returned in default format)

**Example:**

:TRS:DATAALLSW 0                    Turn OFF auto reset for all parameters  
 :TRS:DATAALLSW 1                    Turn ON auto reset for all parameters  
 :TRS:DATAALLSW?                    Return the auto reset function status

**9.2.20.2 Test Data Query****Command Syntax:**

:TRS:DATA?  
 :TRS:DATA: <para>?  
 :TRS:ADATA: <para>?

**Parameters:**

para                                    Indicates the parameter name; the values are as follows:

Parameter Index	Parameter Value	Parameter Meaning
0	TURN	Circle Ratio Result
1	LX	Inductance
2	Q	Quality Factor
3	LK	Leakage
4	CX	Capacitance
5	CXD	Losses
6	ZX	Impedance
7	ACR	AC Resistance
8	DCR	DC Resistance
9	PS	Short-Circuit Test
10	BL	Balance Test
11	PH	Phase

**Example:**

:TRS:DATA:TURN?                    Return circle ratio data and comparison result  
 :TRS:DATA:LX?                        Return inductance data and comparison result  
 :TRS:DATA:LK?                        Return leakage inductance data and comparison result  
 :TRS:DATA:Q?                         Return quality factor data and comparison result

**Note:** The data byte return format is described as follows (take TURN for example):

1 Byte	1 Byte	8 Byte	4 Byte * 60 * 10	1 Byte * 60 * 10	1 Byte	1 or 2 Byte
#	PriSets	Reserved	Test Results	Comparison Results	Total Comparison Results	\n or \r\n

:TRS:DATA? Return all measurement results in hexadecimal format, with a relatively fixed length.

1 Byte	1 Byte	8 Byte	4 Byte * 60 * 10 * 11 (parameter)	1 Byte * 60 * 10 * 11 (parameter)	1 Byte	1 or 2 Byte
#	PriSets	Reserved	Test Results Pa- rameters in Order 1 ~ 10	Comparison Results Parameters in Order 1 ~ 10	Total Comparison Results	\n or \r\n

:TRS:ADATA:TURN? ASCII format returns the specified test result

**Note:** The return data format is as follows (take TURN for example):

```
#seg1, <pri, sec, paraidx, comp, val;> * PriSet * SecSet \n
```

Where seg<sub>1</sub> is the total result of the comparison.

**Parameter:**

0	Not compared
1	Qualified
2   3   4	Unqualified
pri	Specifies the primary index corresponding to the data
sec	Specifies the secondary index corresponding to the data
paraidx	Specifies the parameter function index
comp	The comparison result
val	The measurement result

As above, 5 for a group, is for a winding group of results, the number of cycles PriSet \* SecSet.

### 9.2.20.3 Transformer Operation Status

**Command Syntax:**

:TRS:STAT?

**Return Data:**

IDLE	Indicates the state of not triggered or triggered to the first point before the test
RUN	Test in progress: indicates the state from the start to the end of the test
DATA	Result data is available; i.e. the end of the test
PAUSE	Test paused

**Note:** Suggested application scenario: In the non-automatic data return state, the host reads the data based on the queried state and then takes the initiative to read the data.

### 9.2.20.4 Transformer File Sending

Used for the host to send the transformer test file.

**Command Syntax:**

:TRS:FILL <file byte length>

**Parameters:**

file byte length                      The number of bytes contained in the contents of the transformer file

**Example:**

:TRS:FILL 14336                      Host is about to send data content of 14336 bytes in length

**Note:** 14336 is only a description of the use of the specific value is determined by the **length** of the data content to be sent; you then need to send the specified length of the data content to the instrument, with its bytes in their correct order. Please strictly adhere to the format of the file editing to generate a valid configuration file, otherwise it is easy to make mistakes!

### 9.2.20.5 Stop Transformer Scan

**Command Syntax:**

:TRS:STOP

**Example:**

:TRS:STOP                      Stop the transformer scan. Stopped early in the process, this is equivalent to the reset button on the front panel.

**Note:** Triggering again after stopping will restart the scan from the first parameter on the first page.

## 9.2.21 SYSTem Subsystem Commands

The SYSTem subsystem command set is mainly used to set system-related parameter functions.

### 9.2.21.1 Bus Mode

Used to set the command mode of the communication interface.

**Command Syntax:**

:SYST:BUSMODE?

:SYST:BUSMODE <RS232 | LAN | USBTMC | USBCDC | AUTO>

**Parameter:**

AUTO                      Automatically select the communication interface

RS232 | LAN | USBTMC | USBCDC      Lock the communication interface to a particular communication mode

**Example:**

:SYST:BUSMODE RS232	Set the bus communication as a fixed RS232 interface
:SYST:BUSMODE USB CDC	Set the bus communication as the fixed USB CDC interface
:SYST:BUSMODE AUTO	Set the bus communication to the automatic interface mode
:SYST:BUSMODE?	Return the current communication interface mode

**9.2.21.2 Key Sound**

Used to turn on/off the keypress sound.

**Command Syntax:**

```
:SYST:BEEP?
:SYST:BEEP <0 | 1 | OFF | ON>
```

**Parameter:**

0   OFF	OFF
1   ON	ON

**Example:**

:SYST:BEEP 0	Turn OFF the key sound
:SYST:BEEP 1	Turn ON the key sound
:SYST:BEEP?	Return the current key sound setup

**9.2.21.3 PASS Sound**

Used to set the PASS sound effect.

**Command Syntax:**

```
:SYST:BEEP:PASS?
:SYST:BEEP:PASS <OFF | TS | LL | HS | HL>
```

**Parameter:**

OFF	OFF
TS	Two short beeps
LL	Low long beep
HS	High short beep
HL	High long beep

**Example:**

:SYST:BEEP:PASS OFF	Turn OFF the PASS sound effect
:SYST:BEEP:PASS TS	Set the PASS sound to two short beeps
:SYST:BEEP:PASS HL	Set the PASS sound to high long beep
:SYST:BEEP:PASS?	Return the currently selected PASS sound effect

### 9.2.21.4 FAIL Sound

Used to set the FAIL sound effect.

**Command Syntax:**

```
:SYST:BEEP:FAIL?
```

```
:SYST:BEEP:FAIL <OFF | TS | LL | HS | HL>
```

**Parameter:**

OFF	OFF
TS	Two short beeps
LL	Low long beep
HS	High short beep
HL	High long beep

**Example:**

:SYST:BEEP:FAIL OFF	Turn OFF the FAIL sound effect
:SYST:BEEP:FAIL LL	Set the FAIL sound to low and long beep
:SYST:BEEP:FAIL HS	Set the FAIL sound to high and short beep
:SYST:BEEP:FAIL?	Return the currently selected FAIL sound effect

### 9.2.21.5 DateTime

Used to configure the system's time and date.

**Command Syntax:**

```
:SYST:DATETIME?
```

```
:SYST:DATETIME <year, month, day, hour, minute, second>
```

**Parameter:**

year	Value range 2018 ~ 2999
------	-------------------------

**Example:**

:SYST:DATETIME 2021, 11, 08, 12, 35, 56	Set the date and time to: 2021-11-08 12:35:56
:SYST:DATETIME?	Return the currently defined system time and date

### 9.2.21.6 RS232 Configuration: Baud Rate

Used to set the baud rate.

**Command Syntax:**

```
:SYST:RS232:BAUD?
```

```
:SYST:RS232:BAUD <4800 | 9600 | 19200 | 38400 | 57600 | 115200>
```



**Example:**

:SYST:RS232:BAUD 4800           Set the RS232 baud rate to 4800  
:SYST:RS232:BAUD 38400       Set the RS232 baud rate to 38400  
:SYST:RS232:BAUD?            Return RS232 baud rate

### 9.2.21.7 RS232 Configuration: Bus Address

Used to set the instrument's bus address.

**Command Syntax:**

:SYST:RS232:ADDR?  
:SYST:RS232:ADDR <1 ~ 32>

**Example:**

:SYST:RS232:ADDR 1           Set the instrument's bus address to 1  
:SYST:RS232:ADDR 2           Set the instrument's bus address to 2  
:SYST:RS232:ADDR 32         Set the instrument's bus address to 32  
:SYST:RS232:ADDR?            Return the bus address of the instrument

### 9.2.21.8 Command Mode

Used to set the instrument's communication command mode.

**Command Syntax:**

:SYST:RS232:CMDMODE?  
:SYST:RS232:CMDMODE <SCPI | MODBUS>

**Example:**

:SYST:RS232:CMDMODE SCPI     Set the instrument command mode to SCPI  
:SYST:RS232:CMDMODE MODBUS   Set the command mode to MODBUS  
:SYST:RS232:CMDMODE?         Return the command mode of the instrument

### 9.2.21.9 LAN Configuration: Port Number

Used to set the LAN port number.

**Command Syntax:**

:SYST:LAN:PORT?  
:SYST:LAN:PORT <int>

**Parameter:**

int                            Value range: consult the network management, recommended 1 ~ 65536; the factory default value is 45454

**Example:**

:SYST:LAN:PORT 45454           Set the port number of the LAN port to 45454  
:SYST:LAN:PORT?               Return the port number of the LAN port

**9.2.21.10 LAN Configuration: Port DHCP**

Used to set the LAN port DHCP.

**Command Syntax:**

:SYST:LAN:UDP

**Example:**

:SYST:LAN:UDP?               Automatically obtain the network configuration

**9.2.21.11 LAN Configuration: IP Address**

Used to set the IP address of the LAN port.

**Command Syntax:**

:SYST:LAN:IPAD?  
:SYST:LAN:IPAD <address>

**Example:**

:SYST:LAN:IPAD 192.168.22.209   Set the IP address of the LAN port to 192.168.22.209  
:SYST:LAN:IPAD?               Return the IP address of the LAN port

**9.2.21.12 LAN Configuration: Gateway Address**

Used to set the LAN port gateway address.

**Command Syntax:**

:SYST:LAN:GAT?  
:SYST:LAN:GAT <address>

**Example:**

:SYST:LAN:GAT 192.168.22.1       Set the gateway address of the LAN port to 192.168.22.1  
:SYST:LAN:GAT?               Return gateway address of the LAN port

**9.2.21.13 LAN Configuration: Subnet Mask Address**

Used to set the subnet mask address of the LAN port.

**Command Syntax:**

:SYST:LAN:SMASK?  
:SYST:LAN:SMASK <address>

**Example:**

:SYST:LAN:SMASK 255.255.255.0 Set the subnet mask address of the LAN port to 255.255.255.0

:SYST:LAN:SMASK? Return the subnet mask address of the LAN port

**9.2.21.14 LAN Configuration: DNS Address**

Used to set the DNS address of the LAN port.

**Command Syntax:**

:SYST:LAN:DNS?

:SYST:LAN:DNS <address<sub>1</sub>>, <address<sub>2</sub>>

**Parameter:**

address<sub>1</sub> Primary DNS address

address<sub>2</sub> Backup DNS address

**Example:**

:SYST:LAN:DNS 255.23.12.0, 255.23.14.1 Set the DNS address of the LAN port to 255.23.12.0 (and backup: 255.23.14.1)

:SYST:LAN:DNS? Return the DNS address of the LAN port

**9.2.21.15 LAN Configuration: MAC Address**

Used to query the MAC address of the LAN port.

**Command Syntax:**

:SYST:LAN:MAC?

**Example:**

:SYST:LAN:MAC? Return the MAC address of the LAN port

**9.2.21.16 Update Command**

Used to update the system firmware.

**Command Syntax:**

:SYST:UPDATE APP

**Example:**

:SYST:UPDATE APP Call the default file in the USB flash drive to upgrade

**Note:** In addition, we have the software for the host computer to control the firmware update of the instrument, which can directly send the update file from the host computer and perform the update without the need for a USB flash drive. The issued update file is stored by default in the internal storage of the instrument, such as update2840.sec. Considering that later update files may be relatively large, you can delete this file periodically.

## 9.3 Modbus Commands

### 9.3.1 Write Command Format

The command format is the internal version 2.0 standard; please refer to the following description for details.

#### 9.3.1.1 Sending Format

Instrument address	Function code	High address	Low address	High registers	Low registers	Total number of bytes	Data byte 1	.....	Data byte n	CRC Low	CRC High
--------------------	---------------	--------------	-------------	----------------	---------------	-----------------------	-------------	-------	-------------	---------	----------

#### 9.3.1.2 Return Format

Instrument address	Function code	High address	Low address	High registers	Low registers	CRC Low	CRC High
--------------------	---------------	--------------	-------------	----------------	---------------	---------	----------

- Instrument Address:**  
 This refers to the local address of the instrument, which can be set in the bus address of the instrument's system setting interface. The value range is 1 ~ 31.
- Function Code:**  
 This command can write one or multiple sets of data, so its code is **0x10**.
- High Address and Low Address:**  
 This refers to the storage address of the data in the instrument, which can be a real storage address or a mapped address.
- High Registers and Low Registers:**  
 This indicates that the number of registers written in this operation and the size of each register is 2 bytes.
- Total Number of Bytes:**  
 This represents the total number of bytes written in this operation.
- Data Byte 1 ~ Data Byte n:**  
 Write these data content to the instrument.
- CRC High and CRC Low:**  
 CRC 16-bit check, we use the look-up table method for CRC check.

**Example:** The specific instruction and function setting relationship is detailed in the Appendix Table Modbus command function comparison table (Section 9.3.3)

Assume you set the voltage range to **range 2** (ie 300 V); the storage address of voltage range parameter in the instrument is **0x0003**, and the instrument bus address is **8**.

Then the command is:

0x08	0x10	0x00	0x03	0x00	0x01	0x01	0x02	C5	FD
------	------	------	------	------	------	------	------	----	----

Where, the countdown 3<sup>rd</sup> is corresponding to **20 %** index value of voltage, the type is **char** and accounting for **1** byte.

The return information is as follows:

0x08	0x10	0x00	0x03	0x00	0x01	0xF1	0x50
------	------	------	------	------	------	------	------

## 9.3.2 Read Command Format

### 9.3.2.1 Sending Format

Instrument address	Function code	High address	Low address	High registers	Low registers	CRC Low	CRC High
--------------------	---------------	--------------	-------------	----------------	---------------	---------	----------

### 9.3.2.2 Return Format

Instrument address	Function code	Total number of bytes	Data byte 1	.....	Data byte n	CRC Low	CRC High
--------------------	---------------	-----------------------	-------------	-------	-------------	---------	----------

The function code is: **0x03**

**Example:** The specific instruction and function setting relationship is detailed in the Appendix Table ModeBus command function comparison table (Section 9.3.3);

To read the test value of the voltage in the current mode, the storage address is **0x00A0**, the instrument number is **8**.

Then the command is:

0x08	0x03	0x00	0xA0	0x00	0x02	0xC4	0xB0
------	------	------	------	------	------	------	------

The return information is as follows:

0x08	0x03	0x04	Data byte 1	.....	Data byte 4	CRC Low	CRC High
------	------	------	-------------	-------	-------------	---------	----------

## 9.3.3 CRC16 Calculation Method – Look-Up Table Method

### 1) Define two 256-byte checklists:

High Byte Value Table:

```
const BYTE chCRCHTable[] = //CRC high byte value table
{
0x00, 0xC1, 0x81, 0x40, 0x01, 0xC0, 0x80, 0x41, 0x01, 0xC0, 0x80, 0x41,
0x00, 0xC1, 0x81, 0x40, 0x01, 0xC0, 0x80, 0x41, 0x00, 0xC1, 0x81, 0x40,
0x00, 0xC1, 0x81, 0x40, 0x01, 0xC0, 0x80, 0x41, 0x01, 0xC0, 0x80, 0x41,
0x00, 0xC1, 0x81, 0x40, 0x00, 0xC1, 0x81, 0x40, 0x01, 0xC0, 0x80, 0x41,
0x00, 0xC1, 0x81, 0x40, 0x01, 0xC0, 0x80, 0x41, 0x01, 0xC0, 0x80, 0x41,
0x00, 0xC1, 0x81, 0x40, 0x01, 0xC0, 0x80, 0x41, 0x00, 0xC1, 0x81, 0x40,
0x00, 0xC1, 0x81, 0x40, 0x01, 0xC0, 0x80, 0x41, 0x00, 0xC1, 0x81, 0x40,
0x01, 0xC0, 0x80, 0x41, 0x01, 0xC0, 0x80, 0x41, 0x00, 0xC1, 0x81, 0x40,
0x00, 0xC1, 0x81, 0x40, 0x01, 0xC0, 0x80, 0x41, 0x01, 0xC0, 0x80, 0x41,
0x00, 0xC1, 0x81, 0x40, 0x01, 0xC0, 0x80, 0x41, 0x00, 0xC1, 0x81, 0x40,
0x00, 0xC1, 0x81, 0x40, 0x01, 0xC0, 0x80, 0x41, 0x01, 0xC0, 0x80, 0x41,
0x00, 0xC1, 0x81, 0x40, 0x00, 0xC1, 0x81, 0x40, 0x01, 0xC0, 0x80, 0x41,
0x01, 0xC0, 0x80, 0x41, 0x00, 0xC1, 0x81, 0x40, 0x01, 0xC0, 0x80, 0x41,
0x00, 0xC1, 0x81, 0x40, 0x00, 0xC1, 0x81, 0x40, 0x01, 0xC0, 0x80, 0x41,
0x00, 0xC1, 0x81, 0x40, 0x01, 0xC0, 0x80, 0x41, 0x01, 0xC0, 0x80, 0x41,
0x00, 0xC1, 0x81, 0x40, 0x01, 0xC0, 0x80, 0x41, 0x00, 0xC1, 0x81, 0x40,
```

```

0x00, 0xC1, 0x81, 0x40, 0x01, 0xC0, 0x80, 0x41, 0x01, 0xC0, 0x80, 0x41,
0x00, 0xC1, 0x81, 0x40, 0x00, 0xC1, 0x81, 0x40, 0x01, 0xC0, 0x80, 0x41,
0x00, 0xC1, 0x81, 0x40, 0x01, 0xC0, 0x80, 0x41, 0x01, 0xC0, 0x80, 0x41,
0x00, 0xC1, 0x81, 0x40
};

```

### Low Byte Value Table:

```

const BYTE chCRCLTalbe[] =
{
0x00, 0xC0, 0xC1, 0x01, 0xC3, 0x03, 0x02, 0xC2, 0xC6, 0x06, 0x07, 0xC7,
0x05, 0xC5, 0xC4, 0x04, 0xCC, 0x0C, 0x0D, 0xCD, 0x0F, 0xCF, 0xCE, 0x0E,
0x0A, 0xCA, 0xCB, 0x0B, 0xC9, 0x09, 0x08, 0xC8, 0xD8, 0x18, 0x19, 0xD9,
0x1B, 0xDB, 0xDA, 0x1A, 0x1E, 0xDE, 0xDF, 0x1F, 0xDD, 0x1D, 0x1C, 0xDC,
0x14, 0xD4, 0xD5, 0x15, 0xD7, 0x17, 0x16, 0xD6, 0xD2, 0x12, 0x13, 0xD3,
0x11, 0xD1, 0xD0, 0x10, 0xF0, 0x30, 0x31, 0xF1, 0x33, 0xF3, 0xF2, 0x32,
0x36, 0xF6, 0xF7, 0x37, 0xF5, 0x35, 0x34, 0xF4, 0x3C, 0xFC, 0xFD, 0x3D,
0xFF, 0x3F, 0x3E, 0xFE, 0xFA, 0x3A, 0x3B, 0xFB, 0x39, 0xF9, 0xF8, 0x38,
0x28, 0xE8, 0xE9, 0x29, 0xEB, 0x2B, 0x2A, 0xEA, 0xEE, 0x2E, 0x2F, 0xEF,
0x2D, 0xED, 0xEC, 0x2C, 0xE4, 0x24, 0x25, 0xE5, 0x27, 0xE7, 0xE6, 0x26,
0x22, 0xE2, 0xE3, 0x23, 0xE1, 0x21, 0x20, 0xE0, 0xA0, 0x60, 0x61, 0xA1,
0x63, 0xA3, 0xA2, 0x62, 0x66, 0xA6, 0xA7, 0x67, 0xA5, 0x65, 0x64, 0xA4,
0x6C, 0xAC, 0xAD, 0x6D, 0xAF, 0x6F, 0x6E, 0xAE, 0xAA, 0x6A, 0x6B, 0xAB,
0x69, 0xA9, 0xA8, 0x68, 0x78, 0xB8, 0xB9, 0x79, 0xBB, 0x7B, 0x7A, 0xBA,
0xBE, 0x7E, 0x7F, 0xBF, 0x7D, 0xBD, 0xBC, 0x7C, 0xB4, 0x74, 0x75, 0xB5,
0x77, 0xB7, 0xB6, 0x76, 0x72, 0xB2, 0xB3, 0x73, 0xB1, 0x71, 0x70, 0xB0,
0x50, 0x90, 0x91, 0x51, 0x93, 0x53, 0x52, 0x92, 0x96, 0x56, 0x57, 0x97,
0x55, 0x95, 0x94, 0x54, 0x9C, 0x5C, 0x5D, 0x9D, 0x5F, 0x9F, 0x9E, 0x5E,
0x5A, 0x9A, 0x9B, 0x5B, 0x99, 0x59, 0x58, 0x98, 0x88, 0x48, 0x49, 0x89,
0x4B, 0x8B, 0x8A, 0x4A, 0x4E, 0x8E, 0x8F, 0x4F, 0x8D, 0x4D, 0x4C, 0x8C,
0x44, 0x84, 0x85, 0x45, 0x87, 0x47, 0x46, 0x86, 0x82, 0x42, 0x43, 0x83,
0x41, 0x81, 0x80, 0x40
};

```

## 2) Calculate:

```

WORD CRC16(BYTE* pchMsg, WORD wDataLen)
{
    BYTE chCRCHi = 0xFF; // High CRC byte initialization
    BYTE chCRCLo = 0xFF; // Low CRC byte initialization
    WORD wIndex;          // Index in the CRC loop

    while (wDataLen--)
    {
        // Calculate CRC
        wIndex = chCRCLo ^ *pchMsg++;
        chCRCLo = chCRCHi ^ chCRCHTalbe[wIndex];
        chCRCHi = chCRCLTalbe[wIndex];
    }

    return ((chCRCHi << 8) | chCRCLo);
}

```

## 9.3.4 Command Function Comparison Table

### 9.3.4.1 General Measurement Settings

Instrument Bus Address	Function Code	Command Address	Number of Data Bytes	Data Number	Data Byte	Description																																				
Instrument Address	Read/Write (R/W)	High+Low	High+Low	Data Number	The Value Corresponding to the Address																																					
1 ~ 31	R	0x0000	–	–	–	Return the instrument IDN																																				
	R/W	0x0001	0x0001 ~ 0x0004	1 ~ 4	0x01 ~ 0x	Function; the values are as follows: <table border="1"> <tr><td>0</td><td>CP</td><td>6</td><td>X</td><td>12</td><td>Q</td></tr> <tr><td>1</td><td>CS</td><td>7</td><td>G</td><td>13</td><td>dZ</td></tr> <tr><td>2</td><td>LP</td><td>8</td><td>B</td><td>14</td><td>rZ</td></tr> <tr><td>3</td><td>LS</td><td>9</td><td>Z</td><td>15</td><td>dY</td></tr> <tr><td>4</td><td>RP</td><td>10</td><td>Y</td><td>16</td><td>rY</td></tr> <tr><td>5</td><td>RS</td><td>11</td><td>D</td><td>17</td><td>RD</td></tr> </table>	0	CP	6	X	12	Q	1	CS	7	G	13	dZ	2	LP	8	B	14	rZ	3	LS	9	Z	15	dY	4	RP	10	Y	16	rY	5	RS	11	D	17	RD
0	CP	6	X	12	Q																																					
1	CS	7	G	13	dZ																																					
2	LP	8	B	14	rZ																																					
3	LS	9	Z	15	dY																																					
4	RP	10	Y	16	rY																																					
5	RS	11	D	17	RD																																					
	R/W	0x0002	0x0004	4	float	Frequency																																				
	R/W	0x0003	0x0001	1	0 ~ 3	Speed <table border="1"> <tr><td>0</td><td>FAST</td></tr> <tr><td>1</td><td>MED</td></tr> <tr><td>2</td><td>SLOW</td></tr> <tr><td>3</td><td>SFAST</td></tr> </table>	0	FAST	1	MED	2	SLOW	3	SFAST																												
0	FAST																																									
1	MED																																									
2	SLOW																																									
3	SFAST																																									
	R/W	0x0004	0x0001	1	0 ~ 1	Trigger <table border="1"> <tr><td>0</td><td>CONT</td></tr> <tr><td>1</td><td>SINGLE</td></tr> </table>	0	CONT	1	SINGLE																																
0	CONT																																									
1	SINGLE																																									
	R/W	0x0005	0x0001	1	0 ~ 1	Constant Level <table border="1"> <tr><td>0</td><td>OFF</td></tr> <tr><td>1</td><td>ON</td></tr> </table>	0	OFF	1	ON																																
0	OFF																																									
1	ON																																									
	R/W	0x0006	0x0004	4	float	Trigger Delay: 0 ~ 60.000 s																																				
	R/W	0x0007	0x0004	4	float	Step Delay: 0 ~ 60.000 s																																				
	R/W	0x0008	0x0001	1	0 ~ 1	Voltage Monitoring <table border="1"> <tr><td>0</td><td>OFF</td></tr> <tr><td>1</td><td>ON</td></tr> </table>	0	OFF	1	ON																																
0	OFF																																									
1	ON																																									
	R/W	0x0009	0x0001	1	0 ~ 1	Current Monitoring <table border="1"> <tr><td>0</td><td>OFF</td></tr> <tr><td>1</td><td>ON</td></tr> </table>	0	OFF	1	ON																																
0	OFF																																									
1	ON																																									
	R/W	0x000A	0x0005	5	float+char	AC Level float + 0/1 (v / i)																																				
	R/W	0x000B	0x0001	1	0 ~ 14	AC Range <table border="1"> <tr><td>0</td><td>100k</td><td>5</td><td>2k</td><td>10</td><td>50</td></tr> <tr><td>1</td><td>50k</td><td>6</td><td>1k</td><td>11</td><td>20</td></tr> <tr><td>2</td><td>20k</td><td>7</td><td>500</td><td>12</td><td>10</td></tr> <tr><td>3</td><td>10k</td><td>8</td><td>200</td><td>13</td><td>0.1</td></tr> <tr><td>4</td><td>5k</td><td>9</td><td>100</td><td></td><td></td></tr> </table>	0	100k	5	2k	10	50	1	50k	6	1k	11	20	2	20k	7	500	12	10	3	10k	8	200	13	0.1	4	5k	9	100								
0	100k	5	2k	10	50																																					
1	50k	6	1k	11	20																																					
2	20k	7	500	12	10																																					
3	10k	8	200	13	0.1																																					
4	5k	9	100																																							
	R/W	0x000C	0x0005	5	float+char	DC Bias float + 0 / 1 (v / i)																																				
		0x000D	–	–	–	xx																																				

	R/W	0x000E	0x0001	1	1 ~ 256	Average						
	R/W	0x000F	0x0001	1	0 ~ 1	BIAS Polarity <table border="1"> <tr> <td>0</td> <td>OFF</td> </tr> <tr> <td>1</td> <td>ON</td> </tr> </table>	0	OFF	1	ON		
0	OFF											
1	ON											
	R/W	0x0010	0x0001	1	0 ~ 14	DC Range						
	R/W	0x0011	0x0004	4	float	DC Level						
		0x0012	-	-	-	xx						
	R/W	0x0013	0x0001	1	0 ~ 1	DC Isolation <table border="1"> <tr> <td>0</td> <td>OFF</td> </tr> <tr> <td>1</td> <td>ON</td> </tr> </table>	0	OFF	1	ON		
0	OFF											
1	ON											
	R/W	0x0014	0x0001	1	0 ~ 2	Deviation 1 <table border="1"> <tr> <td>0</td> <td>OFF</td> </tr> <tr> <td>1</td> <td>ABS</td> </tr> <tr> <td>2</td> <td>PER</td> </tr> </table>	0	OFF	1	ABS	2	PER
0	OFF											
1	ABS											
2	PER											
	R/W	0x0015	0x0001	1	0 ~ 2	Deviation 2 <table border="1"> <tr> <td>0</td> <td>OFF</td> </tr> <tr> <td>1</td> <td>ABS</td> </tr> <tr> <td>2</td> <td>PER</td> </tr> </table>	0	OFF	1	ABS	2	PER
0	OFF											
1	ABS											
2	PER											
	R/W	0x0016	0x0004	4	float	Reference 1						
	R/W	0x0017	0x0004	4	float	Reference 2						
	R/W	0x1000	0x0001	1	0 ~ 2	Deviation 3 <table border="1"> <tr> <td>0</td> <td>OFF</td> </tr> <tr> <td>1</td> <td>ABS</td> </tr> <tr> <td>2</td> <td>PER</td> </tr> </table>	0	OFF	1	ABS	2	PER
0	OFF											
1	ABS											
2	PER											
	R/W	0x1001	0x0001	1	0 ~ 2	Deviation 4 <table border="1"> <tr> <td>0</td> <td>OFF</td> </tr> <tr> <td>1</td> <td>ABS</td> </tr> <tr> <td>2</td> <td>PER</td> </tr> </table>	0	OFF	1	ABS	2	PER
0	OFF											
1	ABS											
2	PER											
	R/W	0x1002	0x0004	4	float	Reference 3						
	R/W	0x1003	0x0004	4	float	Reference 4						
	R/W	0x0019	4 × n	4 × n	float × n	Reference value, set 1 ~ 4 reference values The value of n is 1 ~ 4, that is, you can set 1, 2, 3 or 4 reference values at the same time						



### 9.3.4.2 Multi-Parameter Batch Setup

Function Code	Command Address	Number of Data Bytes	Data Number	Data Byte	Description
Read/Write (R/W)	High+Low	High+Low	Data Number	The Value Corresponding to the Address	
R/W	0x1020	n	2n	...	Batch read/write of measurement related parameter settings

The parameters of the n registers (1 ~ n) are as follows:

1	Function 1	11	AC Level Type	21	DC Range	31	DC Bias Type	41	Reference 1	51	Current Monitoring ON/OFF
2	Function 2	12	AC Voltage	22	Trigger Mode	32	DC Bias Voltage	42	Reference 2		
3	Function 3	13		23	Trigger Delay	33		43			
4	Function 4	14	AC Current	24	Step Delay	34	DC Bias Current	44	Reference 3		
5	F1 ON/OFF	15		25		35		45			
6	F2 ON/OFF	16	DC Level	26	Average Count	36	Mode 1 Deviation	46	Reference 4		
7	F3 ON/OFF	17		27	37	47					
8	F4 ON/OFF	18	Speed	28	Bias Source	38	Mode 3 Deviation	48	Constant Level ON/OFF		
9	Frequency	19	Auto Range ON/OFF	29	Bias Output Source	39	Mode 4 Deviation	49	DC Isolation		
		20	AC Range	30	Bias Polarity	40	Reference 1	50	Voltage Monitoring ON/OFF		

**Note:**

- 1 register equals 2 bytes in length.
- Specific register parameter nomenclature and value ranges can be found in the previous part of this section or in the introduction related to the measurement setup parameters.
- The length of data corresponding to a write operation must be 2 times the number of registers.
- The number of registers to be read or written can be from 1 to 45, and the instrument response starts from 1 and cannot be read or written from the center.

Function Code	Command Address	Number of Data Bytes	Data Number	Data Byte	Description
Read/Write (R/W)	High+Low	High+Low	Data Number	The Value Corresponding to the Address	
R/W	0x1020	n	2n	...	Batch read/write of measurement related parameter settings

The parameters of the n registers (1 ~ n) are as follows:

1	Function 1	11	Auto Range ON/OFF	21	Deviation Mode 2	31	AC Voltage	41	DC Bias Voltage	51	Reference 4
2	Function 2	12	AC Range	22	Deviation Mode 3	32	AC Current	42	DC Bias Current		
3	Function 3	13	DC Range	23	Deviation Mode 4	33		43			
4	Function 4	14	Trigger Mode	24	Constant Level ON/OFF	34	DC Level	44	Reference 1		
5	F1 ON/OFF	15	Average Count	25	DC Isolation	35		45			
6	F2 ON/OFF	16	Bias Source	26	Voltage Monitoring ON/OFF	36	Trigger Delay	46	Reference 2		
7	F3 ON/OFF	17	Bias Output Source	27	Current Monitoring ON/OFF	37		47			
8	F4 ON/OFF	18	Bias Polarity	28	Frequency	38	Step Delay	48	Reference 3		
9	AC Level Type	19	DC Bias Type	29		39		49			
10	Speed	20	Bias Mode 1	30	AC Voltage	40	DC Bias Voltage	50	Reference 4		

**Note:**

- 1 register equals 2 bytes in length.
- Specific register parameter nomenclature and value ranges can be found in the previous part of this section or in the introduction related to the measurement setup parameters.
- The length of data corresponding to a write operation must be 2 times the number of registers.
- The number of registers to be read or written can be from 1 to 45, and the instrument response starts from 1 and cannot be read or written from the center.

### 9.3.4.3 Comparison Settings

Instrument Bus Address	Function Code	Command Address	Number of Data Bytes	Data Number	Data Byte	Description				
Instrument Address	Read/Write (R/W)	High+Low	High+Low	Data Number	The Value Corresponding to the Address					
	R/W	0x001C	0x0001	1	0 ~ 1	Comparison Function <table border="1"> <tr> <td>0</td> <td>OFF</td> </tr> <tr> <td>1</td> <td>ON</td> </tr> </table>	0	OFF	1	ON
0	OFF									
1	ON									
	R/W	0x001D	0x0004	4	float	BIN 1 Low				
	R/W	0x001E	0x0004	4	float	BIN 1 High				
	R/W	0x001F	0x0004	4	float	BIN 2 Low				
	R/W	0x0020	0x0004	4	float	BIN 2 High				
	R/W	0x0021	0x0004	4	float	BIN 3 Low				
	R/W	0x0022	0x0004	4	float	BIN 3 High				
	R/W	0x0023	0x0004	4	float	BIN 4 Low				
	R/W	0x0024	0x0004	4	float	BIN 4 High				
	R/W	0x0025	0x0004	4	float	BIN 5 Low				
	R/W	0x0026	0x0004	4	float	BIN 5 High				
	R/W	0x0027	0x0004	4	float	BIN 6 Low				
	R/W	0x0028	0x0004	4	float	BIN 6 High				
	R/W	0x0029	0x0004	4	float	BIN 7 Low				
	R/W	0x002A	0x0004	4	float	BIN 7 High				
	R/W	0x002B	0x0004	4	float	BIN 8 Low				
	R/W	0x002C	0x0004	4	float	BIN 8 High				
	R/W	0x002D	0x0004	4	float	BIN 9 Low				
	R/W	0x002E	0x0004	4	float	BIN 9 High				
	R/W	0x002F	0x0004	4	float	BIN 10 Low				
	R/W	0x0030	0x0004	4	float	BIN 10 High				
	R/W	0x1004	0x0006	6	char+ char+ float	BIN 1 ~ 10 Low <ul style="list-style-type: none"> <li>BIN index 0 ~ 9;</li> <li>abcd index 0 ~ 3</li> <li>float is the value</li> </ul>				
	R/W	0x1005	0x0006	6		BIN 1 ~ 10 High <ul style="list-style-type: none"> <li>BIN index 0 ~ 9</li> <li>abcd index 0 ~ 3</li> <li>float is the value</li> </ul>				

### 9.3.4.4 List Settings

Instrument Bus Address	Function Code	Command Address	Number of Data Bytes	Data Number	Data Byte	Description																																				
Instrument Address	Read/Write (R/W)	High+Low	High+Low	Data Number	The Value Corresponding to the Address																																					
	R/W	0x0050	0x0001	1	1 ~ 201	List Sweep Point																																				
	R/W	0x0051	0x0001	1	0 ~ 1	List Sweep Mode <table border="1"> <tr> <td>0</td> <td>SEQ</td> </tr> <tr> <td>1</td> <td>STEP</td> </tr> </table>	0	SEQ	1	STEP																																
0	SEQ																																									
1	STEP																																									
	R/W	0x0052	–	–	–	–																																				
	R/W	0x0053	0x0001	1	0 ~ 200	The sweep point index position in the current setup																																				
	R/W	0x0054	–	–	–	–																																				
	R/W	0x0055	0x0004	4	float	List Scan Point Frequency																																				
	R/W	0x0056	0x0005	5	float+u16	List Scan Point AC Level +0/1(v/i)																																				
	R/W	0x0057	–	–	–	–																																				
	R/W	0x0058	0x0005	5	float+u16	List Scan Point DC Bias +0/1(v/i)																																				
	R/W	0x005A	0x0001 ~ 0x0004	1 ~ 4	0 ~	Function; the values are as follows: <table border="1"> <tr> <td>0</td> <td>CP</td> <td>6</td> <td>X</td> <td>12</td> <td>Q</td> </tr> <tr> <td>1</td> <td>CS</td> <td>7</td> <td>G</td> <td>13</td> <td>dZ</td> </tr> <tr> <td>2</td> <td>LP</td> <td>8</td> <td>B</td> <td>14</td> <td>rZ</td> </tr> <tr> <td>3</td> <td>LS</td> <td>9</td> <td>Z</td> <td>15</td> <td>dY</td> </tr> <tr> <td>4</td> <td>RP</td> <td>10</td> <td>Y</td> <td>16</td> <td>rY</td> </tr> <tr> <td>5</td> <td>RS</td> <td>11</td> <td>D</td> <td>17</td> <td>RD</td> </tr> </table>	0	CP	6	X	12	Q	1	CS	7	G	13	dZ	2	LP	8	B	14	rZ	3	LS	9	Z	15	dY	4	RP	10	Y	16	rY	5	RS	11	D	17	RD
0	CP	6	X	12	Q																																					
1	CS	7	G	13	dZ																																					
2	LP	8	B	14	rZ																																					
3	LS	9	Z	15	dY																																					
4	RP	10	Y	16	rY																																					
5	RS	11	D	17	RD																																					
	R/W	0x005C	0x0004	4	float	List Scan Point Step Delay																																				
	R/W	0x1006	0x0006	6	char+ char+ float	Low Limit <ul style="list-style-type: none"> <li>point index 0 ~ 200</li> <li>abcd index 0 ~ 3</li> <li>float is the value</li> </ul>																																				
	R/W	0x1007	0x0006	6		High Limit <ul style="list-style-type: none"> <li>point index 0 ~ 200</li> <li>abcd index 0 ~ 3</li> <li>float is the value</li> </ul>																																				
	R	0x100B	9 × n	–	–	<b>Rest List All Test Results</b> <ul style="list-style-type: none"> <li>The number of registers read is n × 9 (i.e., n points)</li> <li>The data for a single point is composed as follows:  <table border="1"> <tr> <td>2Reg</td> <td>2Reg</td> <td>2Reg</td> <td>2Reg</td> <td>1Reg</td> </tr> <tr> <td>P<sub>1</sub></td> <td>P<sub>2</sub></td> <td>P<sub>3</sub></td> <td>P<sub>4</sub></td> <td>cmp</td> </tr> </table> </li> </ul>	2Reg	2Reg	2Reg	2Reg	1Reg	P <sub>1</sub>	P <sub>2</sub>	P <sub>3</sub>	P <sub>4</sub>	cmp																										
2Reg	2Reg	2Reg	2Reg	1Reg																																						
P <sub>1</sub>	P <sub>2</sub>	P <sub>3</sub>	P <sub>4</sub>	cmp																																						
	R	0x100C 0x100D 0x100E	2 × n	–	–	<b>Read List Specified Parameters 1/2/3/4 Test Results</b>																																				

		0x100F				<ul style="list-style-type: none"> <li>The number of registers read is <math>n \times 2</math> (i.e., <math>n</math> points)</li> <li>The data of a single point is composed as follows:                     <table border="1" style="margin-left: 20px;"> <tr><td>2Reg</td></tr> <tr><td><math>P_n</math></td></tr> </table> </li> </ul>	2Reg	$P_n$								
2Reg																
$P_n$																
	R	0x1010	n	-	-	<p><b>Read List Comparison Results</b></p> <ul style="list-style-type: none"> <li>Reading the number of registers as <math>n</math> (i.e. <math>n</math> points)</li> <li>The data of a single point is composed as follows: cmp</li> </ul> <p><b>Values:</b></p> <p>0 not compared            1 PASS            Others FAIL</p> <table border="1" style="margin-left: 20px;"> <tr><td>1Reg</td></tr> <tr><td>cmp</td></tr> </table>	1Reg	cmp								
1Reg																
cmp																
	R	0x1011	4	8	Short (0 ~ 3)	<p><b>Setting the Data Size Returned by the 4 Parameters of the List</b></p> <ul style="list-style-type: none"> <li>The 4 words correspond to the 4-parameter report size</li> </ul> <p><b>Values:</b></p> <p>0 default absolute data size            1 <math>data \times 10^3</math> after reporting            2 <math>data \times 10^6</math> after reporting</p> <p><b>Example:</b></p> <p><b>Write 08 10 10 11 00 04 08 00 00 00 00 00 00 00 00 00 7D D0</b> — Set all 4 parameters to 0</p> <p><b>Write 08 10 10 11 00 04 08 00 01 00 01 00 01 00 01 00 01 C0 D0</b> ---- Set all 4 parameters to 1</p> <p><b>Write 08 10 10 11 00 04 08 00 02 00 02 00 02 00 02 00 02 07 D1</b> ---- Set all 4 parameters to 2</p>										
	R/W	0x3000	W(1+2n) R(2n)	W(1+2n) R(2n)	W(u16)+ n ↑ float	<p>Batch Read and Write:</p> <p><b>List Scan Point Frequency</b></p> <ul style="list-style-type: none"> <li>Write register starts at <math>pt</math>; read register starts at 0</li> <li>The first register, <math>u16</math>, indicates the start point index, <math>pt</math>, with a value from 0 to 200.</li> </ul> <p>The data of the write register is composed as follows:</p> <table border="1" style="margin-left: 20px;"> <tr> <td>1Reg</td> <td>2Reg</td> <td>2Reg</td> <td>...</td> <td>2Reg</td> </tr> <tr> <td>Starting pt</td> <td>f[pt]</td> <td>f[pt+1]</td> <td>...</td> <td>f[pt+n-1]</td> </tr> </table> <p>The data of the read register is composed as follows:</p>	1Reg	2Reg	2Reg	...	2Reg	Starting pt	f[pt]	f[pt+1]	...	f[pt+n-1]
1Reg	2Reg	2Reg	...	2Reg												
Starting pt	f[pt]	f[pt+1]	...	f[pt+n-1]												

						2Reg	2Reg	...	2Reg								
						f[0]	f[1]	...	f[n-1]								
	R/W	0x3001	W(1+2n) R(2n)	W(1+2n) R(2n)	W(u16)+ n ↑ float	Batch Read and Write: <b>Scan Point Level Voltage</b> Read and Write Description is the same as that for address 0x3000.											
	R/W	0x3002	W(1+2n) R(2n)	W(1+2n) R(2n)	W(u16)+ n ↑ float	Batch Read and Write: <b>Scan Point Level Current</b> Read and Write Description is the same as that for address 0x3000.											
	R/W	0x3003	W(1+2n) R(2n)	W(1+2n) R(2n)	W(u16)+ n ↑ float	Batch Read and Write: <b>Scan Point Offset Voltage</b> Read and Write Description is the same as that for address 0x3000.											
	R/W	0x3004	W(1+2n) R(2n)	W(1+2n) R(2n)	W(u16)+ n ↑ float	Batch Read and Write: <b>Scan Point Offset Current</b> Read and Write Description is the same as that for address 0x3000.											
	R/W	0x3005	W(1+2n) R(2n)	W(1+2n) R(2n)	W(u16)+ n ↑ float	Batch Read and Write: <b>Scan Point Step Delay</b> Read and Write Description is the same as that for address 0x3000.											
	R/W	0x3006 0x3007 0x3008 0x3009	W(1+2n) R(2n)	W(1+2n) R(2n)	W(u16)+ n ↑ float	Batch Read and Write: <b>Scan Point Upper Limits</b> Addresses correspond to four parameters as follows: <table border="1" style="margin: 10px auto;"> <tr> <td>0x3006</td> <td>0x3007</td> <td>0x3008</td> <td>0x3009</td> </tr> <tr> <td>Parameter 1 (A)</td> <td>Parameter 2 (B)</td> <td>Parameter 3 (C)</td> <td>Parameter 4 (D)</td> </tr> </table> Read and Write Description is otherwise the same as that for address 0x3000.				0x3006	0x3007	0x3008	0x3009	Parameter 1 (A)	Parameter 2 (B)	Parameter 3 (C)	Parameter 4 (D)
0x3006	0x3007	0x3008	0x3009														
Parameter 1 (A)	Parameter 2 (B)	Parameter 3 (C)	Parameter 4 (D)														
	R/W	0x300A 0x300B 0x300C 0x300D	W(1+2n) R(2n)	W(1+2n) R(2n)	W(u16)+ n ↑ float	Batch Read and Write: <b>Scan Point Lower Limits</b> Addresses correspond to four parameters as follows: <table border="1" style="margin: 10px auto;"> <tr> <td>0x300A</td> <td>0x300B</td> <td>0x300C</td> <td>0x300D</td> </tr> <tr> <td>Parameter 1 (A)</td> <td>Parameter 2 (B)</td> <td>Parameter 3 (C)</td> <td>Parameter 4 (D)</td> </tr> </table> Read and Write Description is otherwise the same as that for address 0x3000.				0x300A	0x300B	0x300C	0x300D	Parameter 1 (A)	Parameter 2 (B)	Parameter 3 (C)	Parameter 4 (D)
0x300A	0x300B	0x300C	0x300D														
Parameter 1 (A)	Parameter 2 (B)	Parameter 3 (C)	Parameter 4 (D)														

						<p>Batch Read and Write:</p> <p><b>Scan Point Function</b></p> <p>Addresses correspond to four parameters as follows:</p> <table border="1"> <tr> <td>0x300E</td> <td>0x300F</td> <td>0x3010</td> <td>0x3011</td> </tr> <tr> <td>Parameter 1 (A)</td> <td>Parameter 2 (B)</td> <td>Parameter 3 (C)</td> <td>Parameter 4 (D)</td> </tr> </table> <p>(Write registers start at point pt; read registers start at point 0)</p> <p>The first register u16 indicates the starting point index pt and takes the value 0 ~ 200.</p> <p>The data of the write register is composed as follows:</p> <table border="1"> <tr> <td>1Reg</td> <td>1Reg</td> <td>1Reg</td> <td>...</td> <td>1Reg</td> </tr> <tr> <td>Starting pt</td> <td>func[pt]</td> <td>func[pt+1]</td> <td>...</td> <td>func[pt+n-1]</td> </tr> </table> <p>The data of the read register is composed as follows:</p> <table border="1"> <tr> <td>2Reg</td> <td>2Reg</td> <td>...</td> <td>2Reg</td> </tr> <tr> <td>func[0]</td> <td>func[1]</td> <td>...</td> <td>func[n-1]</td> </tr> </table> <p>Function with the following parameter cross-reference:</p> <table border="1"> <tr> <td>0</td> <td>CP</td> <td>6</td> <td>X</td> <td>12</td> <td>Q</td> </tr> <tr> <td>1</td> <td>CS</td> <td>7</td> <td>G</td> <td>13</td> <td>dZ</td> </tr> <tr> <td>2</td> <td>LP</td> <td>8</td> <td>B</td> <td>14</td> <td>rZ</td> </tr> <tr> <td>3</td> <td>LS</td> <td>9</td> <td>Z</td> <td>15</td> <td>dY</td> </tr> <tr> <td>4</td> <td>RP</td> <td>10</td> <td>Y</td> <td>16</td> <td>rY</td> </tr> <tr> <td>5</td> <td>RS</td> <td>11</td> <td>D</td> <td>17</td> <td>RD</td> </tr> </table>	0x300E	0x300F	0x3010	0x3011	Parameter 1 (A)	Parameter 2 (B)	Parameter 3 (C)	Parameter 4 (D)	1Reg	1Reg	1Reg	...	1Reg	Starting pt	func[pt]	func[pt+1]	...	func[pt+n-1]	2Reg	2Reg	...	2Reg	func[0]	func[1]	...	func[n-1]	0	CP	6	X	12	Q	1	CS	7	G	13	dZ	2	LP	8	B	14	rZ	3	LS	9	Z	15	dY	4	RP	10	Y	16	rY	5	RS	11	D	17	RD
0x300E	0x300F	0x3010	0x3011																																																																	
Parameter 1 (A)	Parameter 2 (B)	Parameter 3 (C)	Parameter 4 (D)																																																																	
1Reg	1Reg	1Reg	...	1Reg																																																																
Starting pt	func[pt]	func[pt+1]	...	func[pt+n-1]																																																																
2Reg	2Reg	...	2Reg																																																																	
func[0]	func[1]	...	func[n-1]																																																																	
0	CP	6	X	12	Q																																																															
1	CS	7	G	13	dZ																																																															
2	LP	8	B	14	rZ																																																															
3	LS	9	Z	15	dY																																																															
4	RP	10	Y	16	rY																																																															
5	RS	11	D	17	RD																																																															
	R/W	0x300E 0x300F 0x3010 0x3011	W(1+n) R(n)	W(1+n) R(n)	W(u16)+ n ↑ u16																																																															

### 9.3.4.5 Curve Settings

Instrument Bus Address	Function Code	Command Address	Number of Data Bytes	Data Number	Data Byte	Description				
Instrument Address	Read/Write (R/W)	High+Low	High+Low	Data Number	The Value Corresponding to the Address					
	R/W	0x0090	0x0001	1	0 ~ 1	LCR Curve: Scale <table border="1"> <tr> <td>0</td> <td>AUTO</td> </tr> <tr> <td>1</td> <td>HOLD</td> </tr> </table>	0	AUTO	1	HOLD
0	AUTO									
1	HOLD									
	R/W	0x0092	0x0001	1	0 ~ 1	LCR Curve: Coordinate <table border="1"> <tr> <td>0</td> <td>Linear</td> </tr> <tr> <td>1</td> <td>Logarithmic</td> </tr> </table>	0	Linear	1	Logarithmic
0	Linear									
1	Logarithmic									
	R/W	0x0094	0x0001	1	0 ~ 1	LCR Curve: Mode <table border="1"> <tr> <td>0</td> <td>SEQ</td> </tr> <tr> <td>1</td> <td>STEP</td> </tr> </table>	0	SEQ	1	STEP
0	SEQ									
1	STEP									

	R/W	0x0096	0x0001	1	0 ~ 4	LCR Curve: Points <table border="1"> <tr><td>0</td><td>51</td></tr> <tr><td>1</td><td>101</td></tr> <tr><td>2</td><td>201</td></tr> <tr><td>3</td><td>401</td></tr> <tr><td>4</td><td>801</td></tr> </table>	0	51	1	101	2	201	3	401	4	801
0	51															
1	101															
2	201															
3	401															
4	801															
	R/W	0x0097	0x0001	1	0 ~ 1	LCR Trace: Max-Min <table border="1"> <tr><td>0</td><td>OFF</td></tr> <tr><td>1</td><td>ON</td></tr> </table>	0	OFF	1	ON						
0	OFF															
1	ON															
	R/W	0x0098	0x0001	1	0 ~ 4	LCR Curve: Start Size										
	R/W	0x0099	0x0001	1	0 ~ 4	LCR Curve: Stop Size										

### 9.3.4.6 User Correction Settings

Instrument Bus Address	Function Code	Command Address	Number of Data Bytes	Data Number	Data Byte	Description										
Instrument Address	Read/Write (R/W)	High+Low	High+Low	Data Number	The Value Corresponding to the Address											
	R/W	0x0031	0x0001	2	0 ~ 1	Open-Circuit Correction <table border="1"> <tr><td>0</td><td>OFF</td></tr> <tr><td>1</td><td>ON</td></tr> <tr><td>2</td><td>Full Freq Open-Circuit Correction</td></tr> <tr><td>3</td><td>DCR Correction</td></tr> </table>	0	OFF	1	ON	2	Full Freq Open-Circuit Correction	3	DCR Correction		
0	OFF															
1	ON															
2	Full Freq Open-Circuit Correction															
3	DCR Correction															
	R/W	0x0032	0x0001	2	0 ~ 1	Short-Circuit Correction <table border="1"> <tr><td>0</td><td>OFF</td></tr> <tr><td>1</td><td>ON</td></tr> <tr><td>2</td><td>Full Freq Short-Circuit Correction</td></tr> <tr><td>3</td><td>DCR Correction</td></tr> </table>	0	OFF	1	ON	2	Full Freq Short-Circuit Correction	3	DCR Correction		
0	OFF															
1	ON															
2	Full Freq Short-Circuit Correction															
3	DCR Correction															
	R/W	0x0033	0x0001	2	0 ~ 1	Load Correction Function										
	R/W	0x0034	0x0001	2	0 ~ 1	Cable Length										
	R/W	0x0035	–	–	–	–										
	R/W	0x0036	0x0001	2	0 ~ 9	Calibration Point										
	R/W	0x0037	0x0004	4	float	Frequency Setup										
	R/W	0x0038	0x0001	2	0 ~ 4	Frequency Point ON/OFF <table border="1"> <tr><td>0</td><td>OFF</td></tr> <tr><td>1</td><td>ON</td></tr> <tr><td>2</td><td>Single Freq Open-Circuit Correction</td></tr> <tr><td>3</td><td>Single Freq Short-Circuit Correction</td></tr> <tr><td>4</td><td>Single Freq Load Correction</td></tr> </table>	0	OFF	1	ON	2	Single Freq Open-Circuit Correction	3	Single Freq Short-Circuit Correction	4	Single Freq Load Correction
0	OFF															
1	ON															
2	Single Freq Open-Circuit Correction															
3	Single Freq Short-Circuit Correction															
4	Single Freq Load Correction															
	R/W	0x0039	0x0004	4	float	Reference A for Calibration Point										
	R/W	0x003A	0x0004	4	float	Reference B for Calibration Point										

## 9.3.4.7 System Settings

Instrument Bus Address	Function Code	Command Address	Number of Data Bytes	Data Number	Data Byte	Description																																																								
Instrument Address	Read/Write (R/W)	High+Low	High+Low	Data Number	The Value Corresponding to the Address																																																									
	W	0x0040	0x0001	1	1	Start Test (Trigger Key Function)																																																								
	W	0x0041	0x0001	1	1	Stop Test (Reset Key Function)																																																								
	R	0x0042	-	-	-	Read the Results																																																								
	R/W	0x0043	0x0001	1	char	Page Switching; value range of the parameters is as follows: <table border="1" style="margin-left: 20px;"> <tr><td>0</td><td>Measurement</td><td>1</td><td>List</td></tr> <tr><td>2</td><td>LCR</td><td>3</td><td>Measurement Settings</td></tr> <tr><td>4</td><td>Limit Settings</td><td>5</td><td>List Settings</td></tr> <tr><td>6</td><td>LCR Settings</td><td>7</td><td>System Settings</td></tr> <tr><td>8</td><td>File Management</td><td>9</td><td>User Corrections</td></tr> <tr><td>10</td><td>Handler</td><td></td><td></td></tr> <tr><td>11</td><td>Single Test</td><td>12</td><td>Single Test Settings</td></tr> <tr><td>15</td><td>TRS Scan</td><td>16</td><td>TRS ID</td></tr> <tr><td>17</td><td>Pin to Fixture</td><td>18</td><td>1831 Scan</td></tr> <tr><td>19</td><td>1901 Scan</td><td>20</td><td>Pin Settings</td></tr> <tr><td>21</td><td>Condition Setting</td><td>22</td><td>Deviation Deduction</td></tr> <tr><td>23</td><td>Quick Setup</td><td>24</td><td>Statistics</td></tr> <tr><td>25</td><td>Tools</td><td>26</td><td>Scanning Self-Test</td></tr> <tr><td>27</td><td>Scan Hand</td><td></td><td></td></tr> </table>	0	Measurement	1	List	2	LCR	3	Measurement Settings	4	Limit Settings	5	List Settings	6	LCR Settings	7	System Settings	8	File Management	9	User Corrections	10	Handler			11	Single Test	12	Single Test Settings	15	TRS Scan	16	TRS ID	17	Pin to Fixture	18	1831 Scan	19	1901 Scan	20	Pin Settings	21	Condition Setting	22	Deviation Deduction	23	Quick Setup	24	Statistics	25	Tools	26	Scanning Self-Test	27	Scan Hand		
0	Measurement	1	List																																																											
2	LCR	3	Measurement Settings																																																											
4	Limit Settings	5	List Settings																																																											
6	LCR Settings	7	System Settings																																																											
8	File Management	9	User Corrections																																																											
10	Handler																																																													
11	Single Test	12	Single Test Settings																																																											
15	TRS Scan	16	TRS ID																																																											
17	Pin to Fixture	18	1831 Scan																																																											
19	1901 Scan	20	Pin Settings																																																											
21	Condition Setting	22	Deviation Deduction																																																											
23	Quick Setup	24	Statistics																																																											
25	Tools	26	Scanning Self-Test																																																											
27	Scan Hand																																																													
	R/W	0x0045	0x0001	1	0 ~ 1	Keypress Sound <table border="1" style="margin-left: 20px;"> <tr><td>0</td><td>OFF</td></tr> <tr><td>1</td><td>ON</td></tr> </table>	0	OFF	1	ON																																																				
0	OFF																																																													
1	ON																																																													
	R/W	0x0045	0x0001	1	0 ~ 4	Pass Sound <table border="1" style="margin-left: 20px;"> <tr><td>0</td><td>OFF</td></tr> <tr><td>1</td><td>Two Short</td></tr> <tr><td>2</td><td>Two High</td></tr> <tr><td>3</td><td>High Short</td></tr> <tr><td>4</td><td>High Long</td></tr> </table>	0	OFF	1	Two Short	2	Two High	3	High Short	4	High Long																																														
0	OFF																																																													
1	Two Short																																																													
2	Two High																																																													
3	High Short																																																													
4	High Long																																																													
	R/W	0x0045	0x0001	1	0 ~ 4	Fail Sound <table border="1" style="margin-left: 20px;"> <tr><td>0</td><td>OFF</td></tr> <tr><td>1</td><td>Two Short</td></tr> <tr><td>2</td><td>Two High</td></tr> <tr><td>3</td><td>High Short</td></tr> <tr><td>4</td><td>High Long</td></tr> </table>	0	OFF	1	Two Short	2	Two High	3	High Short	4	High Long																																														
0	OFF																																																													
1	Two Short																																																													
2	Two High																																																													
3	High Short																																																													
4	High Long																																																													
	R/W	0x0045	0x0001	1	0 ~ 1	Language <table border="1" style="margin-left: 20px;"> <tr><td>0</td><td>English</td></tr> <tr><td>1</td><td>Chinese</td></tr> </table>	0	English	1	Chinese																																																				
0	English																																																													
1	Chinese																																																													
	R/W	0x004E	0x0001	1	0 ~ 2	Bias Source <table border="1" style="margin-left: 20px;"> <tr><td>0</td><td>100 mA</td></tr> <tr><td>1</td><td>2 A</td></tr> <tr><td>2</td><td>External ST1778</td></tr> </table>	0	100 mA	1	2 A	2	External ST1778																																																		
0	100 mA																																																													
1	2 A																																																													
2	External ST1778																																																													



## 9.3.4.8 File Management Settings

Instrument Bus Address	Function Code	Command Address	Number of Data Bytes	Data Number	Data Byte	Description						
Instrument Address	Read/Write (R/W)	High+Low	High+Low	Data Number	The Value Corresponding to the Address							
	W	0x1008	0x0001	1	char (0 ~ 1)	Save Test Result to USB <table border="1"> <tr> <td>0</td> <td>OFF</td> </tr> <tr> <td>1</td> <td>ON</td> </tr> </table>	0	OFF	1	ON		
0	OFF											
1	ON											
	W	0x1009	0x0001	1	char (0 ~ 1)	Save List Results to USB <table border="1"> <tr> <td>0</td> <td>OFF</td> </tr> <tr> <td>1</td> <td>ON</td> </tr> </table>	0	OFF	1	ON		
0	OFF											
1	ON											
	W	0x100A	0x0001	1	char (0 ~ 1)	Save Curve Results to USB <table border="1"> <tr> <td>0</td> <td>OFF</td> </tr> <tr> <td>1</td> <td>ON</td> </tr> </table>	0	OFF	1	ON		
0	OFF											
1	ON											
	R/W	0x2005	0x0001	2	char(0 ~ 50)	Load the specified file in the internal files directory. The value of n ranges from 0 to 50. Specifies a file in the files root directory in the following format: <table border="1"> <tr> <td>LCR Bridge</td> <td>LCR1.sta, LCR2.sta, LCR3.sta, <b>LCRn.sta</b></td> </tr> <tr> <td>Transformer Single Group</td> <td>TRT1.trt, TRT2.trt, TRT3.trt, <b>TRTn.trt</b></td> </tr> <tr> <td>Transformer Scanning</td> <td>TRS1.t40, TRS2.t40, TRS3.t40, <b>TRSn.t40</b></td> </tr> </table> Reading this register means querying whether an internal file has been loaded, and if so, returning the size of n (2 bytes in length) corresponding to its presence in the data. If there is no internal file being loaded, then no n is returned, and the return is: <b>08 03 00 F0 F2</b>	LCR Bridge	LCR1.sta, LCR2.sta, LCR3.sta, <b>LCRn.sta</b>	Transformer Single Group	TRT1.trt, TRT2.trt, TRT3.trt, <b>TRTn.trt</b>	Transformer Scanning	TRS1.t40, TRS2.t40, TRS3.t40, <b>TRSn.t40</b>
LCR Bridge	LCR1.sta, LCR2.sta, LCR3.sta, <b>LCRn.sta</b>											
Transformer Single Group	TRT1.trt, TRT2.trt, TRT3.trt, <b>TRTn.trt</b>											
Transformer Scanning	TRS1.t40, TRS2.t40, TRS3.t40, <b>TRSn.t40</b>											
	W	0x2006	0x0001	2	char(0 ~ 50)	Load the specified file in the usb directory of the flash drive. n value range: 0 ~ 50 Specify the file in the USB root directory in the same format as above.						

## 9.4 Examples of Writing Commands

### 9.4.1 Examples of LCR Scan Commands

Step	Command	Description	
1	General Parameters	DISP:PAGE TSME	Go to the curve page.
		TRIG:SOUR SING	Set the trigger source to single trigger.
		FREQ 1000	Set the common frequency; the sweep frequency is also determined by the start and end points.
		VOLT 1	Set the test AC level.
		BIAS:VOLT 0	Set the bias voltage. If you need to add bias, you must issue the command BIAS:STAT ON before the test and the command BIAS:STAT OFF after the test.
2	LCR Parameters	TSSE:POINT 101	Set the number of points.
		TSSE:SMODE SEQ	Set the scan mode to sequential.
		TSSE:MODE FREQ	Set the scan object to frequency, i.e. horizontal coordinate.
		TSSE:FORM LIN	Set the point distribution mode to linear.
		TSSE:SWEEP 1e3, 1e6	Set the start and end points of the horizontal coordinate.
		TSSE:IMP Z, CS, LS, D	Set the result parameters for the 4 vertical coordinates.
3	Trigger Test	TRIG	Run a test.
		TRIG:STAT?	Query the test status; returns RUN 1 if there is a test running and RUN 0 if there is not.
4	Query Results	Read test results after the query reaches RUN 0	Query the test results, see the section on Query Curve Scanning Results, query the required data as needed (because of the large amount of data).
		FETC:TRACE:Y 1?	Query the results of all points of parameter 1.
		FETC:TRACE:Y 3?	Query all points of parameter 3.

### 9.4.2 Examples of Transformer Test Commands

Step	Command	Description	
1	Trigger Test	TRIG	Run a test.
		TRIG:STAT?	Query the test status; returns RUN 1 if there is a test running and RUN 0 if there is not.
2	Query Results	Read test results after the query reaches RUN 0	Query the test results, see the section on Query Curve Scanning Results, query the required data as needed (because of the large amount of data).
		TRS:AFET?	For example, the ASCII data corresponding to a measurement object.
		TRS:DATA?	For example, the hexadecimal results corresponding to all points (untested points are automatically padded with 0).
		Other Query Commands	See sections 9.2.16 and 9.2.20.

# 10 Handler Interface Description

ST2840 series instruments provide users with a Handler interface, which is mainly used for the output of sorting results. When the automatic component sorting test system is used, this interface provides the communication signal with the system, as well as the sorting result output signal.

The BIN sorting and list sweep sorting of the bridge module uses the 57BR-4036L interface.

The transformer single group test sorting also uses the 57BR-4036L interface output.

The transformer scanning (built-in scanning board) sorting uses two DR-25P-bend hole interface output; and the transformer scanning (external scanning box) sorting uses the DR-25P-bend hole interface output that comes with the scanning box.

For the specific location of the interface, refer to the introduction of the rear panel given in Chapter 2. The Handler Interface design is flexible; upon using different operating procedures, all output signal states are defined according to the specific requirements.

## 10.1 BIN Sorting

The interface model provided by the BIN sorting instrument is 57BR-4036L, which provides /BIN1 ~ /BIN10 ten-BIN sorting and total PASS and FAIL signals.

### 10.1.1 Technology Description

#### 10.1.1.1 Output Signal

Active low (default), open collector, optoelectronic isolation.

Table 10-1 Output Signals

Signal	Overview
/BIN1 ~ /BIN10 PASS, FAIL	Result Output
/INDEX	"Analog Measurement End" Signal
/EOM	"End of All Measurements" Signal
/ALARM	Provides an alert when a momentary power failure or processor interface board reset is detected.

### 10.1.1.2 Input Signal

Optoelectronic isolation.

Table 10-2 Input Signals

Signal	Overview
/KEY_LOCK	Key Lock (locks the front panel keyboard, including the touch screen)
/EXT_TRIG	External Trigger: pulse width $\geq 1 \mu s$

### 10.1.1.3 Signal Line Description

The Handler interface has 3 signals: comparison output, control output and control input. The following are the signal definitions of the Handler Interface when the BIN comparison function is used.

**Comparison Output Signal:**

- /BIN1 ~ /BIN10
- PASS
- FAIL

**Control Output Signal:**

- /INDEX (analog measurement end signal)
- /EOM (measurement end and comparison data valid signal)
- /ALARM (instrument power down signal)

**Control Input Signal:**

- /EXT.TRIG (external trigger signal)
- /Keylock

The interface diagram of the above pins is shown in Figure 10-1. See Table 10-3 for the signal assignment and brief description of the above pins. The timing diagram is shown in Figure 10-3.

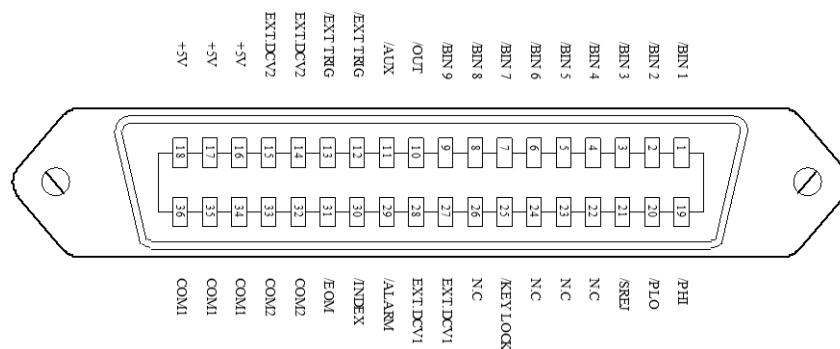

Figure 10-1 Interface Diagram

**Note:** Figure 10-1 is just the interface definition of the BIN sorting, and the definition of the list sweep sorting and the transformer single test sorting are different.

Table 10-3 Signal Distribution Table for the Pins Comparison Function

Pin	Signal	Signal Direction	Description
1	/BIN1	Output	BIN sorting result. All /BIN outputs are open collector outputs.
2	/BIN2		
3	/BIN3		
4	/BIN4		
5	/BIN5		
6	/BIN6		
7	/BIN7		
8	/BIN8		
9	/BIN9		
10	/BIN10		
11	Undefined	Output	Factory measurement signal, please do not connect.
12	/EXT.TRIG	Input	<b>External Trigger:</b> When the trigger mode is set to Single, your ST2840 instrument will be triggered by the positive-edge in this pin.
13			
14	EXT.DCV2	Input	<b>External DC Voltage 2:</b> The DC provider pin for the optoelectronic coupling signal (/EXT_TRIG, /KeyLock, /ALARM, /INDEX, /EOM).
15			
16	+5 V	Output	<b>The Internal Power +5 V:</b> It is not recommended to use the internal power. If you do use the internal power, please ensure that the current is lower than 0.3 A and that the signal line is far from the disturbance source.
17			
18			
19	/PASS	Output	As long as the measurement result is in any one of /BIN1 ~ /BIN10, the output will be /PASS (see Figure 10-2).
20	/FAIL	Output	If the measurement result is not in any one of /BIN1 ~ /BIN10, the output will be /FAIL (see Figure 10-2).
21	Undefined	Output	Factory measurement signal, please do not connect.
22			
23			
24			
25	/KEY LOCK	Input	When this single is effective, all the front panel function keys and touch screen of ST2840 are locked and no longer work.
27	EXT.DCV1	Input	<b>The External DC Voltage 1:</b> The pull-up DC power provider pin for optoelectronic coupling signal (/BIN ~ /BIN10, /PASS, /FAIL).
28			

29	/ALARM	Output	Warning that the circuit has been interrupted.
30	/INDEX	Output	When the analog test is finished and the UNKNOWN terminal can be connected to another DUT, /INDEX is output. But the comparison signal is output until the /EOM signal.
31	/EOM	Output	<b>End of Measurement:</b> Once the test data and the comparison results are output, this signal is also output.
32 33	COM2	–	The reference ground for external power EXTV2.
34 35 36	COM1	–	The reference ground for external power EXTV1.

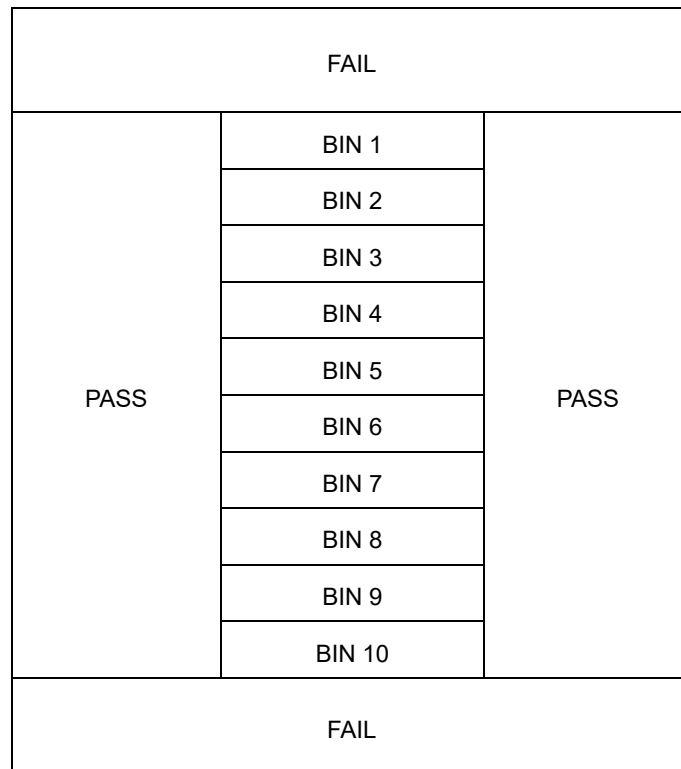
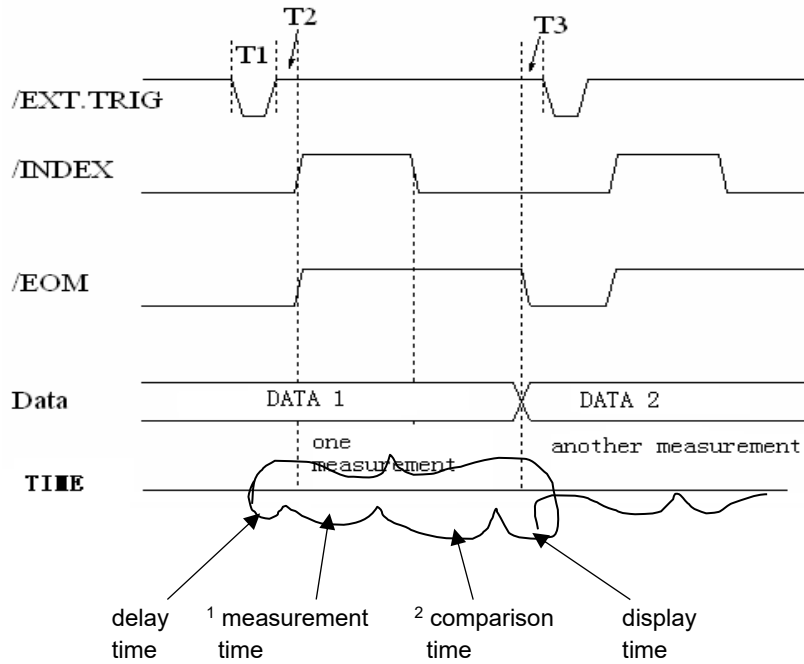

Figure 10-2 Example of the Distribution Area of the Comparison Function Signals /PASS and /FAIL



Time	Minimum	Maximum
T1: trigger pulse-width	1μs	—
T2: delay time	200μs	Display time 200μs
T3: the trigger waiting time after /EOM output	0μs	—

<sup>1</sup> For the measurement time, please refer to section 8.1.9.

<sup>2</sup> The typical comparison time is approximately 0.1 ms.

Figure 10-3 Timing Chart

### 10.1.2 Electrical Features

As it is shown above, the signal definition for the comparison and the list sweep comparison are different. But the electrical feature is same. So the description can be applied to BIN comparison and list sweep comparison.

#### 10.1.2.1 DC Isolation Output Signal

Each DC output (pin 1 to 11, 19 to 24, and 29 to 31) is isolated via an open collector optocoupler output. The output voltage of each line is set by a pull-up resistor on the Handler Interface board. The pull-up resistor is connected with the internal supply voltage (+5 V) or with the external supply voltage (EXTV: +5V ~ 24V) by jumper.

The DC isolated output signal utilizes a dedicated electrical system which is independent of the control output signal. Therefore, the processor board has a common line for two separate circuits: COM1 and COM2.

The electrical characteristics of the DC isolated output are divided into two types (see

Table 10-4). The output circuit configuration of the measurement result output signal is shown in Figure 10-5, and the output circuit configuration of the control output signal is shown in Figure 10-4.



Table 10-4 DC Isolation Output Electrical Features

Output Signal	Output Rated Voltage		Maximum Current	Reference Ground for the Circuit
	LOW	HIGH		
Comparison Signal: <ul style="list-style-type: none"> <li>• /BIN1 ~ /BIN10</li> <li>• /PASS</li> <li>• /FAIL</li> </ul>	≤ 0.5 V	+5 V ~ +24 V	6 mA	Internal Pull-Up Voltage: <ul style="list-style-type: none"> <li>• ST2840 GND</li> <li>• EXT V1: COM1</li> </ul>
Control Signal: <ul style="list-style-type: none"> <li>• /INDEX</li> <li>• /EOM</li> <li>• /ALARM</li> </ul>				Internal Pull-Up Voltage: <ul style="list-style-type: none"> <li>• ST2840 GND</li> <li>• EXT V2: COM2</li> </ul>

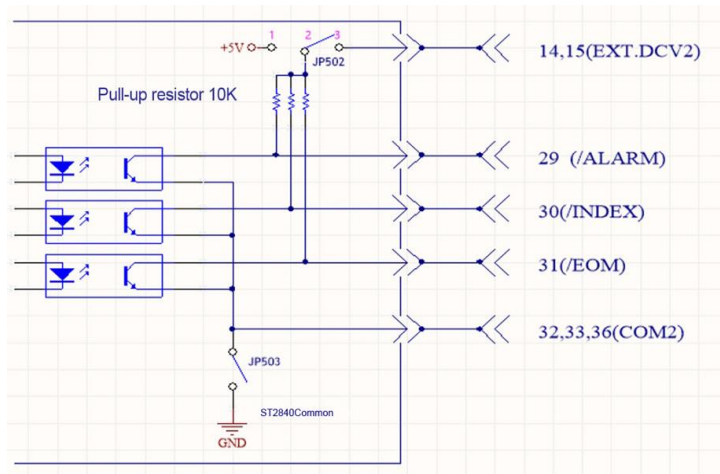

Figure 10-4 Control Signal Output Circuit

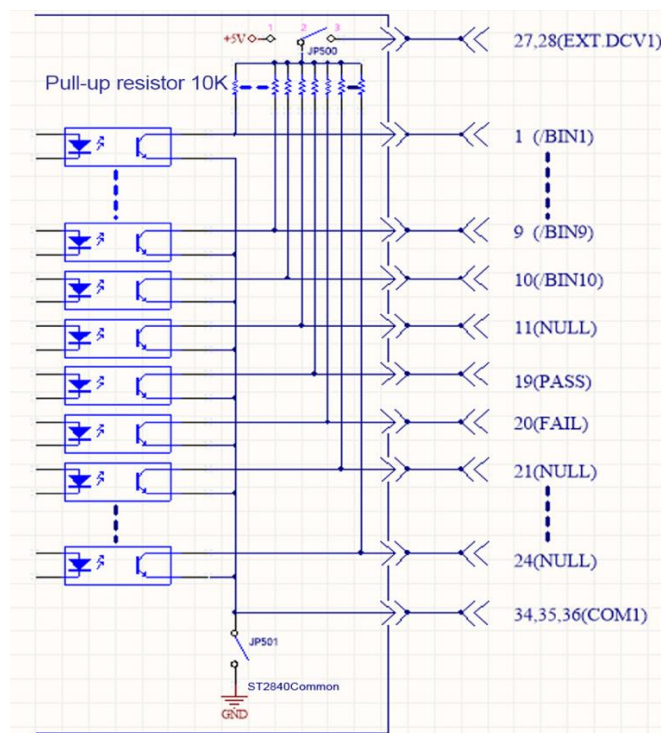

Figure 10-5 Comparison Result Signal Output Circuit

### 10.1.2.2 DC Isolation Input Signal

DC isolation input signals include the /EXT\_TRIG and /KEY\_LOCK signals.

The /EXT\_TRIG signal (pin 12 and pin 13) is input to the LED cathode side of the optocoupler.

The instrument is triggered when the signal increases from LOW to HIGH. The optocoupler LED (anode side) can be driven by an internal pull-up voltage (+5 V) or an external voltage (EXT.DCV2).

The /KEY\_LOCK signal (pin 25) is input to the optocoupler LED (on the cathode side). As long as this is low level, the keys on the front panel of the instrument will all be locked. The optocoupler LED (anode side) can be driven by internal voltage (+5 V) or external voltage (EXT.DCV2).

The input circuit configuration of the DC isolation input signal is shown in Figure 10-6.

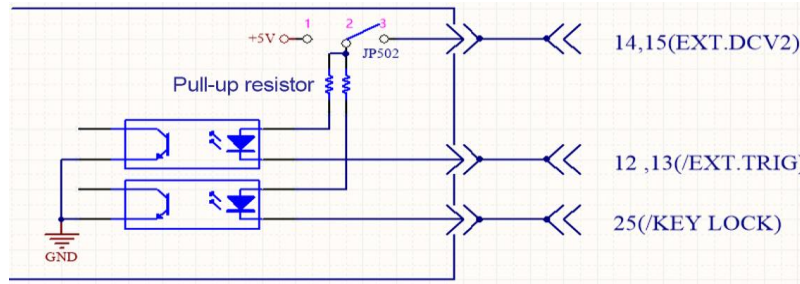

Figure 10-6 Input Signal Circuit Configuration

### 10.1.3 Handler Wiring Instructions of BIN Sorting

This section focuses on an example of the wiring between ST2840 and a typical PLC. The wiring example only introduces the wiring of two PLCs, that is, the PLC input circuit common anode and the PLC input circuit common cathode. For PLCs with other types of input circuits, please consult customer service for further assistance.

The PLC input circuit common anode means that the current flows in from the common terminal of the module and flows out from the input channel of the module, which is often referred to as the source wiring method.

The PLC input circuit common cathode means that the current flows in from the input channel of the module and flows out from the common terminal of the module, which is often referred to as the drain wiring method.

Figure 10-7 shows the PLC wiring diagram where the handler interface and input circuit are common anode when using BIN sorting, and Figure 10-8 shows the equivalent PLC wiring diagram where the handler interface and input circuit are common cathode.

The factory default of ST2840 series instruments is external power supply. That is, pins 2 and 3 of JP500 are short-circuited, pins 2 and 3 of JP502 are short-circuited, JP501 is open, and JP503 is open. Therefore, be sure to connect the power supply to the external power supply pin when using it.

If you need to use the internal power supply of the instrument, you need to change the jumper mode of JP500 ~ JP503; please consult customer service for further information.

<b>Warning!</b>	
	<p>16, 17, and 18 are the 5 V power supply inside the instrument and cannot be connected to any external power supply, otherwise the instrument will get damaged.</p> <p>Considering the anti-interference ability of the instrument, it is recommended to provide and use an external power supply as the pull-up power supply for the optocoupler.</p>

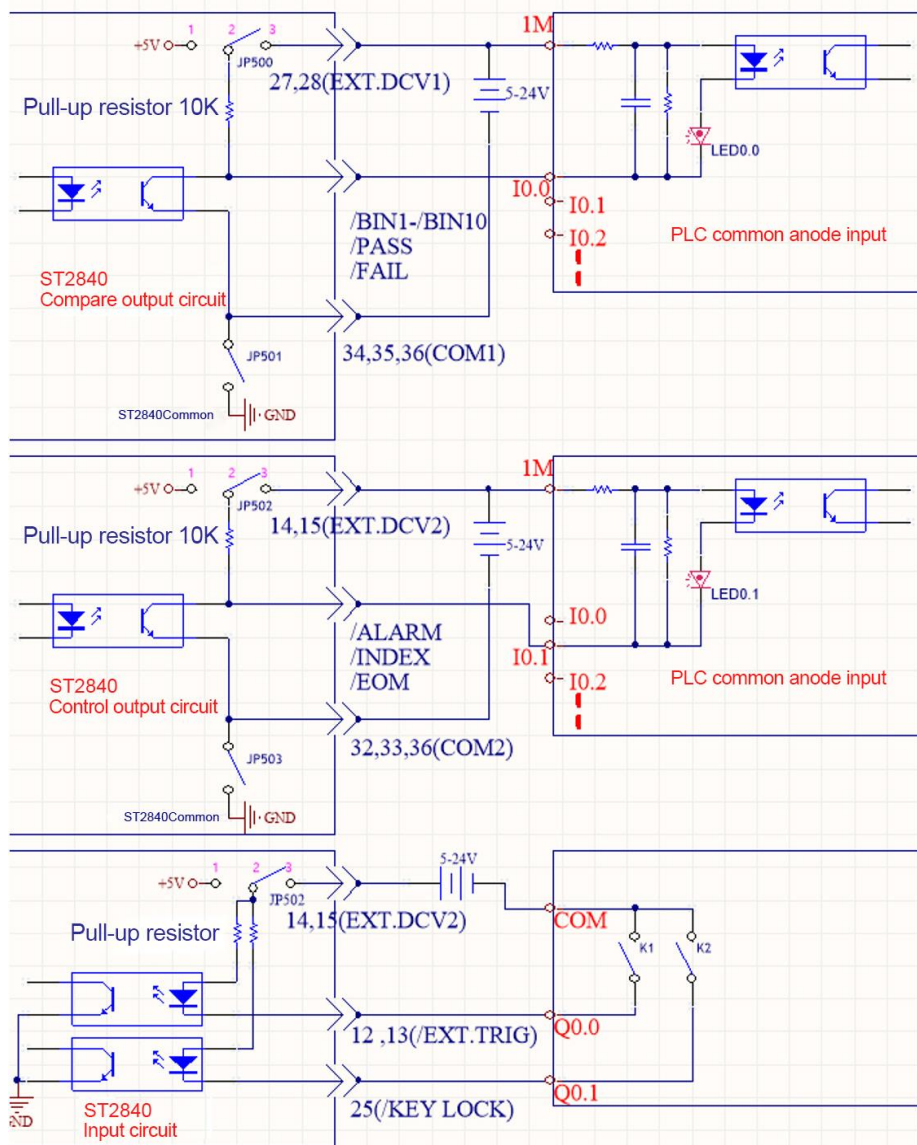

Figure 10-7 PLC Wiring Diagram Where Handler Interface and Input Circuit are Common Anode

EXT.DCV1 and EXT.DCV2 can use the same set of external power supplies, or they can use different sets of power supplies. The corresponding low end of EXT.DCV1 is COM1, and the corresponding low end of EXT.DCV2 is COM2. The input circuit and the control output circuit use the same group of power supplies, namely EXT.DCV2.

The wiring method provided in this figure is a typical connection method, and it needs to be flexibly applied according to the actual situation in practical application.

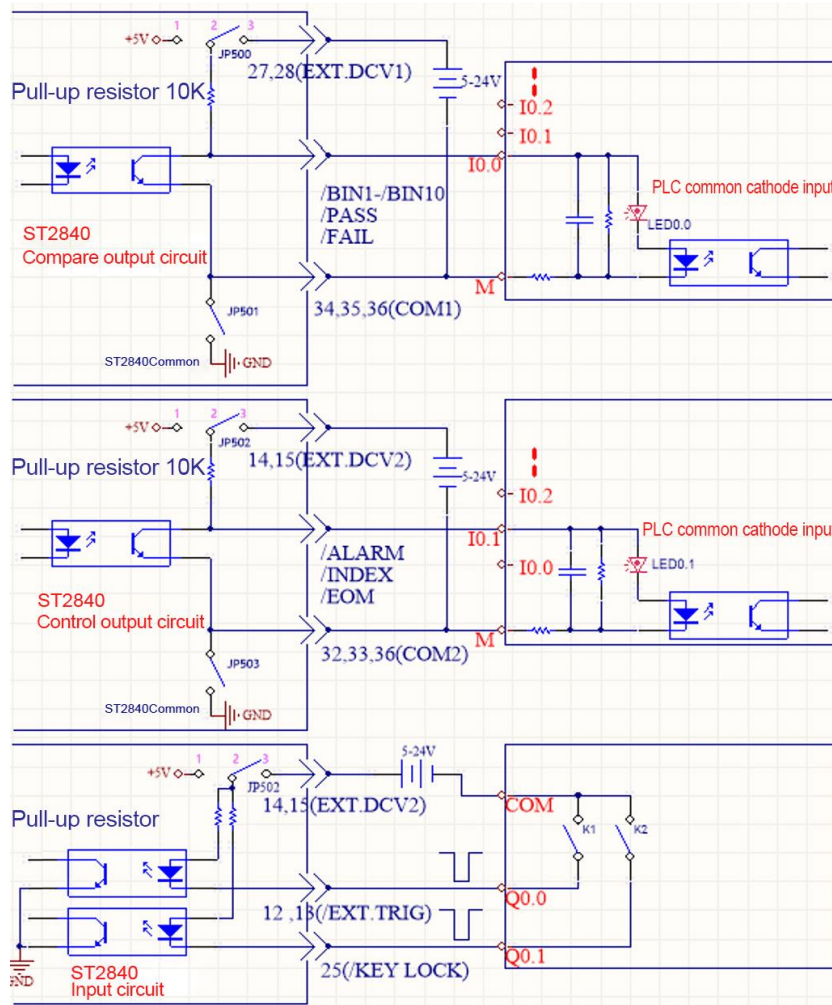

Figure 10-8 PLC Wiring Diagram Where Handler Interface and Input Circuit are Common Cathode

## 10.1.4 Using Operations

After the Handler Interface is correctly wired to the PLC, set the limit list to use the comparison function. Then set the Handler Interface accordingly so that it can output/input signal.

### 10.1.4.1 Comparison Function Setting Procedure

The following operation steps are the steps of the comparison function using the Handler Interface (only for the functions of the automatic component analyzer).

- 1) Press the [SETUP] key, select <Limit Setup> in the menu on the right side of the display, and enter the limit setup page.
- 2) Move the cursor to "Comp", select ON in the menu area on the right side of the screen, and the comparator function will be enabled.
- 3) Move the cursor to "Count", then select ON in the menu area on the right side of the screen, and the counting function will be enabled.
- 4) Move the cursor to "Mode", then select "Tolerance" or "Continuous" in the menu area on the right side of the screen.
- 5) Set the BIN sorting deviation type, reference value, BIN limit and related options on the <Limit Setup> page.
- 6) Press [DISP] to enter the <Meas Display> page, and enter the corresponding page to measure the DUT.

**Note:** The ON/OFF of the comparison function and the ON/OFF of the counting function can also be set in the <Meas Display> page.

## 10.2 List Sweep

When using the list sweep sorting, the interface model provided by the instrument is 57BR-4036L (the same interface as the BIN sorting), and provides /FAIL1 ~ /FAIL10 and the total /PASS and /FAIL signals.

### 10.2.1 List Sweep Sorting Logic

A maximum of 4 parameters can be set for each sweep point. The upper and lower limits of the corresponding parameter settings indicate that they participate in the sorting. If the upper and lower limits are not set, they are not considered in the sorting.

All the parameters considered in the sorting among the 4 parameters are qualified, indicating that the sweep point is qualified. As long as there is one unqualified sweep point, the sweep point is judged to be unqualified. In the list sweep display interface, the P/F column at the end of each sweep point will display PASS or FAIL, and the sweep points without upper and lower limits will be displayed at the corresponding P/F.

Sweep points 1 ~ 10 correspond to /BIN1 ~ /BIN10 in sequence, and all are active low. The sorting results of sweep point 11 and subsequent sweep points do not have separate sorting signals. If all the sweep points with upper and lower limits are qualified, a total PASS signal will be output, and if one of the sweep points with upper and lower limits is set unqualified, a FAIL signal will be output. Sweep points that do not have upper and lower limits set do not participate in the sorting.

### 10.2.2 Technical Description

#### 10.2.2.1 List Sweep Output Signal

Active low, open collector, optoelectronic isolation

Table 10-5 Output Signals

Signal	Overview
/BIN1 ~ /BIN10 PASS, FAIL	Result Output
/INDEX	"Analog Measurement End" Signal
/EOM	"End of All Measurements" Signal
/ALARM	Provides an alert when a momentary power failure or processor interface board reset is detected.

#### 10.2.2.2 List Sweep Input Signal

The input signal is the same as for BIN sorting (see section 10.1.1.2).

#### 10.2.2.3 Signal Line Definition

The list sweep sorting Handler Interface uses three signals: compare output, control input and control output. The following are the signal definitions of the Handler Interface when the list sweep sorting function is used.

The signal definition of the list sweep comparison function is different from that of the BIN comparison function. Its definition is as follows:

**Comparison Output Signal:**

- /FAIL1 ~ /FAIL10
- PASS
- FAIL

The /FAIL1 ~ /FAIL10 signal indicates the successful pass or the out-of-tolerance judgment of each sweep point, see Figure 10-9. The /PASS and /FAIL signals are indicated as total judgment signals. These signals will be output when a sweep measurement is completed.

**Control Output Signal:**

- /INDEX (analog measurement completion signal)
- /EOM (measurement end and comparison data valid signal)
- /ALARM (instrument power down signal)

**SEQ Sweep Mode:** The /INDEX signal registers after the analog measurement of the last sweep point is completed. The /EOM signal registers after each step of measurement and comparison is completed.

**STEP Sweep Mode:** The /INDEX signal registers after the analog measurement of each sweep point is completed. The /EOM signal registers after each step of measurement and comparison is completed.

The timing diagram is shown in Figure 10-10.

**Control Input Signal:** /EXT.TRIG (external trigger signal)

The interface diagram of the above pins is shown in Figure 10-1. See Table 10-6 for the signal assignment and brief description of the above pins.

Table 10-6 Pin Distribution Table of the List Sweep Sorting Function

Pin	Signal	Signal Direction	Description
1	/FAIL1	Output	Out of the limit of sweep point 1
2	/FAIL2		Out of the limit of sweep point 2
3	/FAIL3		Out of the limit of sweep point 3
4	/FAIL4		Out of the limit of sweep point 4
5	/FAIL5		Out of the limit of sweep point 5
6	/FAIL6		Out of the limit of sweep point 6
7	/FAIL7		Out of the limit of sweep point 7
8	/FAIL8		Out of the limit of sweep point 8
9	/FAIL9		Out of the limit of sweep point 9
10	/FAIL10		Out of the limit of sweep point 10
11	Undefined	Output	Factory test, please do not use.
19	/PASS	Output	All points in the measurement result are passed, it is /PASS.
20	/FAIL	Output	As long as one point in the measurement result fails, it is /FAIL.
30	/INDEX	Output	<b>SEQ:</b> The /INDEX signal registers after the analog measurement of the last sweep point is completed, and the UNKNOWN test terminal of the ST2840 can

			<p>be connected to the next device under test (DUT). However, the comparison result signal does not register until the /EOM signal (see Figure 10-10).</p> <p><b>STEP:</b> The /INDEX signal is asserted valid after the analog measurement of each sweep point is completed. However, the comparison result signal does not register until the /EOM signal (see Figure 10-10).</p>
31	/EOM	Output	<p><b>End of Measurement</b></p> <p><b>Sequential Sweep Mode (SEQ):</b> The /EOM signal registers after the entire list sweep measurement is completed and all comparisons are done (see Figure 10-10).</p> <p><b>Single-Step Sweep Mode (STEP):</b> The /EOM signal registers after each sweep point measurement is completed and all comparisons are done. The comparison result signal remains until the /EOM signal of the final sweep point (see Figure 10-10).</p>
Other	-	-	The definition is the same as that of the comparison (see Table 10-3).

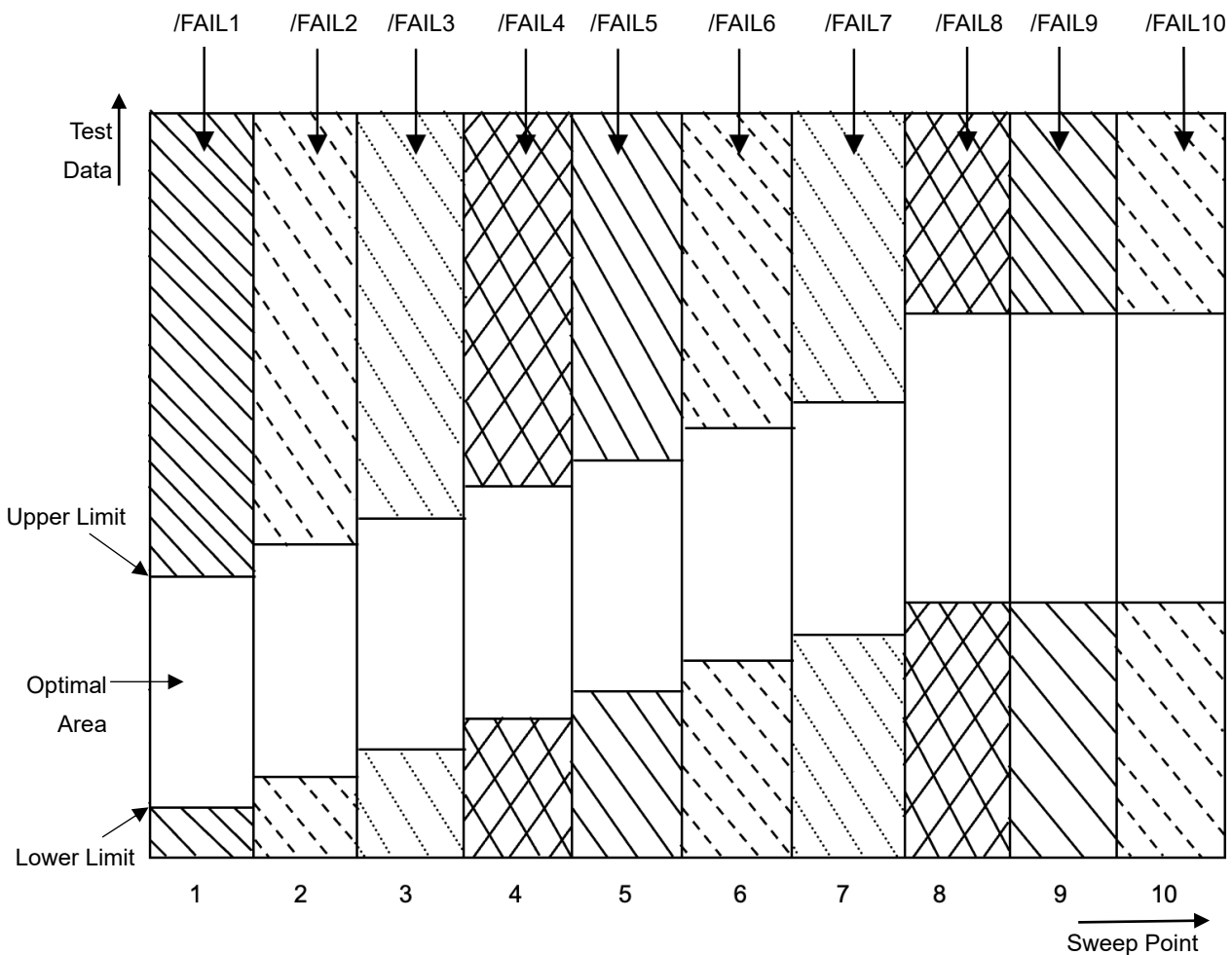

Figure 10-9 Signal Area of the List Sweep Comparison

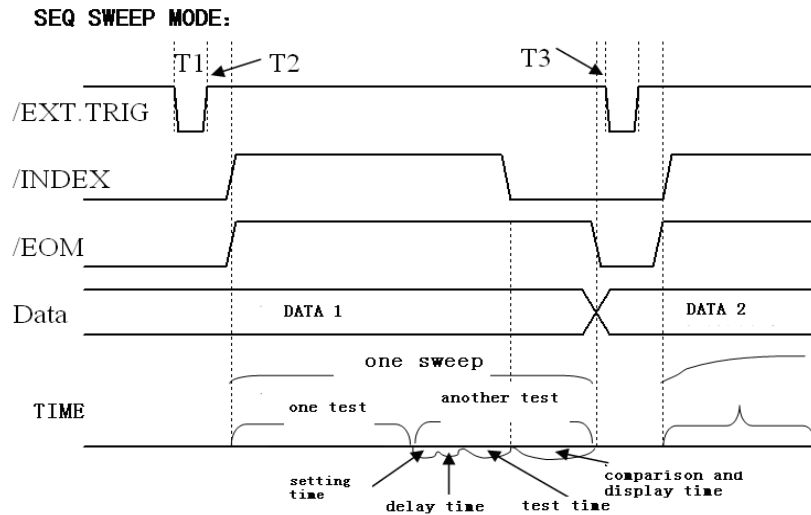

Figure 10-10 Timing Chart (Sequential Mode)

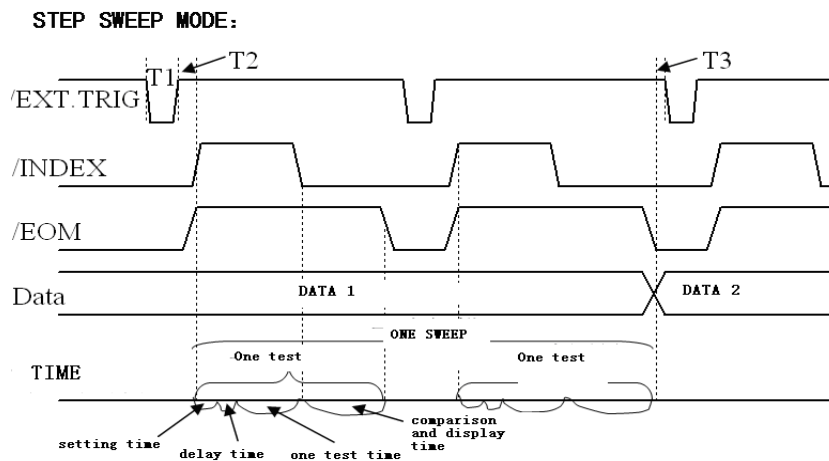

Figure 10-11 Timing Chart (Single-Step Mode)

**Note:**

- The setting time includes the correction ON/OFF time.
- The comparison and display time is 4.5 ms approximately.

**10.2.3 Electrical Features**

The meanings of some signals in the list sweep comparison function and the BIN sorting function are different. However, the electrical characteristics of these signals are the same in both operations, so refer to 10.1.2 for a description of the electrical characteristics of the list sweep sorting function.

**10.2.4 Wiring Instructions**

The list sweep and BIN sorting share the same Handler Interface in the hardware circuit, and the electrical properties corresponding to the same pin numbers are exactly the same. It is essentially the same as the PLC wiring diagram. Therefore, for the wiring diagrams please refer to 10.1.3.



## 10.2.5 Using the List Sweep Comparison

Using the Handler Interface, set the high and low limits in the list sweep to use the comparison function. Then set the Handler Interface so that it can OUTPUT/INPUT signal. The following are the steps to take in order to use the Handler Interface list sweep comparison function.

### 10.2.5.1 List Sweep Compare Function Setting Steps

- 1) Press the [SETUP] button and click [List Setup] in the menu on the right side of the screen to enter the <List Sweep Setup> page.
- 2) In the <List Sweep Setup> menu, set the sweep method, sweep frequency point, reference value, upper/lower limits, etc.
- 3) Press [DISP] to enter the <List Display> page. For a full description of this page, please refer to the section on the [DISP] menu key.

## 10.3 Transformer Single-Group Measurement

The interface model provided to sort transformer single measurement results is 57BR-4036L, which offers separate sorting of 12 parameters such as /FAIL1 ~ /FAIL12, and the total /PASS and /FAIL signals.

### 10.3.1 Sorting Logic

The sorting signal of the first parameter in the single-group setting page corresponds to /FAIL1, the second parameter corresponds to /FAIL2, and so on; the last parameter corresponds to /FAIL12. During measurement, whichever parameter fails the corresponding sorting signal will change. If all parameters pass the test, the PASS signal is output; as long as a minimum of one parameter does not, the /FAIL signal is output.

### 10.3.2 Technical Description

#### 10.3.2.1 Output Signal

Active low, open collector, optoelectronic isolation.

Table 10-7 Output Signals

Signal	Overview
/FAIL1 ~ /FAIL12, /PASS, /FAIL	Result Output
/INDEX	"Analog Measurement End" Signal
/EOM	"End of All Measurements" Signal
/ALARM	Provides an alert when a momentary power failure or processor interface board reset is detected.

### 10.3.2.2 Input Signal

Optoelectronic isolation.

Table 10-8 Input Signals

Signal	Overview
/KEY_LOCK	Key Lock (locks the front panel keyboard, including the touch screen)
/EXT_TRIG	External Trigger: pulse width $\geq 1\mu\text{s}$

### 10.3.2.3 Signal Line Definition

The Handler Interface of transformer single test uses three kinds of signals: comparison output, control input and control output. The following is the signal definition of the Handler Interface when using the transformer single measurement function.

#### Comparison Output Signal:

- /FAIL1 ~ /FAIL12
- /PASS
- /FAIL

#### Control Output Signal:

- /INDEX (analog measurement end signal)
- /EOM (measurement end and comparison data valid signal)
- /ALARM (instrument power down signal)

#### Control Input Signal:

- /EXT.TRIG (external trigger signal)
- /Keylock

See Table 10-9 for the signal assignment and brief description of the above pins.

Table 10-9 The Signal Assignment of the Pins

Pin	Signal	Signal Direction	Description
1	/FAIL1	Output	Sorting result All /FAIL (failure signal) outputs are open collector outputs.
2	/FAIL2		
3	/FAIL3		
4	/FAIL4		
5	/FAIL5		
6	/FAIL6		
7	/FAIL7		
8	/FAIL8		
9	/FAIL9		
10	/FAIL10		
11	/FAIL11		

12 13	/EXT.TRIG	Input	<b>External Trigger:</b> When the trigger mode is set to single, the ST2840 is triggered by a falling edge pulse signal applied to this pin.
14 15	/EXT.DCV2	Input	<b>External DC Voltage 2:</b> The DC provider pin for the optoelectronic coupling signal (/EXT_TRIG, /KeyLock, /ALARM, /INDEX, /EOM)
16 17 18	+5 V	Output	<b>The Internal Power +5 V:</b> It is <u>not</u> recommended to use the internal power! If you do, please ensure that the current is lower than 0.3 A and the signal line is far from the disturbance source.
19	/PASS	Output	As long as the measurement result is in any one of /FAIL1 ~ /FAIL12, /PASS will be output.
20	/FAIL	Output	If the measurement result is not in any one of /FAIL1 ~ /FAIL12, /FAIL will be output.
21	/FAIL12	Output	Sorting result of parameter 12.
22 23 24	Undefined	Output	Factory measurement signal, please do not connect.
25	/KEY LOCK	Input	With this signal, all the front panel function keys and touch screen of ST2840 are locked and no longer work.
27 28	EXT.DCV1	Input	<b>The External DC Voltage 1:</b> The pull-up DC power provider pin for optoelectronic coupling signal (/BIN1 ~ /BIN10, /PASS, /FAIL).
29	/ALARM	Output	Warning that the circuit has been interrupted.
30	/INDEX	Output	Indicates the analog test is finished and the UNKNOWN terminal can be connected to another DUT. The comparison signal remains effective until the /EOM signal.
31	/EOM	Output	<b>End of Measurement:</b> This signal is output when the test data and comparison results are available.
32 33	COM2	–	The reference ground for external power EXTV2.
34 35 36	COM1	–	The reference ground for external power EXTV1.

### 10.3.3 Electrical Features

The definition of some signals differs between the transformer single-measurement sorting function, the BIN sorting function and the list sweep sorting function, but the electrical properties of each pin number are exactly the same.

### 10.3.3.1 DC Isolation Output Signal

Each DC output (pins 1 to 11, 19 to 24, and 29 to 31) is isolated via an open collector optocoupler output. The output voltage of each line is set by a pull-up resistor on the Handler Interface board. The pull-up resistor is connected to either the internal supply voltage (+5 V) or the external supply voltage (EXTV: +5 V ~ 24 V) by jumper.

The DC isolation output signal utilizes a dedicated electrical system which is independent of the control output signal. Therefore, the processor board has a common line for two separate circuits: COM1 and COM2.

The electrical characteristics of the DC isolated output are divided into two types, see Table 10-10. The output circuit configuration of the measurement result output signal is shown in Figure 10-5, and the output circuit configuration of the control output signal is shown in Figure 10-4.

Table 10-10 Electric Features of the DC Isolation Output

Output Signal	Output Rated Voltage		Maximum Current	Reference Ground for the Circuit
	LOW	HIGH		
Comparison Signal: <ul style="list-style-type: none"> <li>• /FAIL1 ~ /FAIL12</li> <li>• /PASS</li> <li>• /FAIL</li> </ul>	≤ 0.5 V	+5 V ~ +24 V	6 mA	Internal Pull-Up Voltage: <ul style="list-style-type: none"> <li>• ST2840 GND</li> <li>• EXTV1: COM1</li> </ul>
Control Signal: <ul style="list-style-type: none"> <li>• /INDEX</li> <li>• /EOM</li> <li>• /ALARM</li> </ul>			5 mA	Internal Pull-Up Voltage: <ul style="list-style-type: none"> <li>• ST2840 GND</li> <li>• EXTV2: COM2</li> </ul>

### 10.3.3.2 DC Isolation Input Signal

DC isolation input signals include the /EXT\_TRIG and /KEY\_LOCK signals.

The /EXT\_TRIG signal (pin 12 and pin 13) is input to the LED cathode side of the optocoupler. The instrument is triggered when the signal increases from LOW to HIGH. The optocoupler LED (anode side) can be driven by an internal pull-up voltage (+5 V) or an external voltage (EXT.DCV2).

The /KEY\_LOCK signal (pin 25) is input to the optocoupler LED (on the cathode side). As long as this is at low level, the keys on the front panel of the instrument will all be locked. The optocoupler LED (anode side) can be driven by an internal voltage (+5 V) or an external voltage (EXT.DCV2).

The input circuit configuration of the DC isolation input signal is shown in Figure 10-6.

## 10.3.4 Wiring Instructions for Transformer Single-Group Measurement

The Handler's wiring operation for a single-group measurement of the transformer is exactly the same as the wiring method of the BIN sorting with the same pin number. The wiring diagram of the common anode PLC is shown in Figure 10-7, and the wiring diagram of the common cathode PLC is shown in Figure 10-8.

## 10.3.5 Using the Transformer Single-Group Measurement Function

After the Handler Interface is correctly connected to the PLC, the deviation mode can be selected in the deviation column on the single group setting page ( $\Delta$ ;  $\Delta\%$ ).

The lower limit of each parameter can be set in the column corresponding to the lower limit, and the upper limit of each parameter can be set in the column corresponding to the upper limit.

The first parameter of the single group setting page corresponds to /FAIL1, the second parameter corresponds to /FAIL2, and so on; the twelfth parameter corresponds to /FAIL12. You can select ON in the comparison item on the single group setting page.

If the measurement switch of each parameter is set to ON, and the upper and lower limits are defined, then the parameter is considered in the sorting. Note that a parameter is not considered in sorting without setting its upper and lower limits.

## 10.4 Transformer Scan Handler Description

For the transformer scan, Handler uses two DR-25P sockets, namely Trans Handler and Trans Controller. It can provide up to 30 independent sorting signals NS1 ~ NS30, in addition to PASS, NG, TEST and other signals.

### 10.4.1 Technical Description

#### 10.4.1.1 Output Signal

Active low, open collector, optoelectronic isolation, ULN2003 Drive Enhancement.

Table 10-11 Output Signals

Signal	Overview
NS1 ~ NS30, PASS, FAIL	Result Output
/TEST	"All Measurement End" Signal

#### 10.4.1.2 Input Signal

Active low, optoelectronic isolation.

Table 10-12 Input Signals

Signal	Overview
EXT_RESET	Reset Signal
EXT_START	External Trigger Signal

### 10.4.1.3 Signal Line Definition

The Handler Interface of transformer scan uses three signals: compare output, control input, and control output. The following are the signal definitions of the Handler Interface when using this function:

#### Comparison Output Signals:

- /NS1 ~ /NS30
- /PASS
- /FAIL

#### Control Output Signals:

- /TEST (analog measurement completion signal)

#### Control Input Signals:

- /EXT\_START (external trigger signal)
- /EXT\_RESET (reset signal)

See Table 10-13 (Trans Handler) and Table 10-14 (Trans Controller) for the signal assignments and brief description of the above pins.

Table 10-13 Signal Assignment of Transformer Scan Pins (Trans Handler)

Pin	Signal	Signal Direction	Description
1	/NS1	Output	<b>Sorting Signal Line:</b> All NS outputs are collector outputs and have different definitions in different sorting modes.
2	/NS2		
3	/NS3		
4	/NS4		
5	/NS5		
6	/NS6		
7	/NS7		
8	/NS8		
9	/NS9		
10	/TEST	Output	<b>End of Measurement:</b> This signal is output when the test data and comparison results are available.
11	+5 V	Output	<b>The Internal Power +5 V:</b> It is <u>not</u> recommended to use the internal power! If you do, please ensure that the current is lower than 0.3 A and the signal line is far from the disturbance source.
12			
13			
14	/GND	Output	–
15			
16			
17			
18	24 V-	Output	Cathode of cylinder power supply

19	/EXT_GND	Input	The reference ground for external power EXT_VCC
20	24 V+	Output	Anode of cylinder power supply
21	/EXT_VCC	Input	<b>External DC Voltage:</b> The DC provider pin for the optoelectronic coupling signal (/NS1 ~ /NS30, /PASS, /FAIL, /TEST)
22	/EXT_RESET	Input	Reset signal
23	/EXT_START	Input	External trigger signal
24	/FAIL	Output	
25	/PASS	Output	

Table 10-14 Signal Assignment of Transformer Scan Pins (Trans Controller)

Pin	Signal	Signal Direction	Description
1	/NS10	Output	<b>Sorting Signal Line:</b> All NS outputs are collector outputs and have different definitions in different sorting modes.
2	/NS11		
3	/NS12		
4	/NS13		
5	/NS14		
6	/NS15		
7	/NS16		
8	/NS17		
9	/NS18		
10	/NS19		
11	/NS20		
12	/NS21		
13	/NS22		
14	/NS23		
15	/NS24		
16	/NS25		
17	/NS26		
18	/NS27		
19	/NS28		
20	/NS29		
21	/NS30		
22	+5 V	Output	<b>The Internal Power +5 V:</b> It is <u>not</u> recommended to use the internal power! If you do, please ensure that the current is lower than 0.3 A and the signal line is far from the disturbance source.
23			
24	GND	Output	
25			

## 10.4.2 Electrical Features

### 10.4.2.1 DC Isolation Output Signal

Each DC output (pins 1-10, 24, 25 of Trans Handler and pins 1-21 of Trans Controller) are isolated by optocoupler and output from the collector after ULN2003 drive enhancement. The output voltage of each line is related to the power supply voltage used. The high level of the internal power supply is 5 V, and the high level of the external power supply is the external power supply voltage. Connect with internal supply voltage (+5 V) or with external supply voltage (EXTV: +5 V ~ 24 V) by jumper.

The DC isolated output signal utilizes a dedicated electrical system which is independent of the control output signal. Therefore, a common line for a separate circuit on the processor board: GND\_EXT.

The electrical characteristics of the DC isolated output are divided into two types, see Table 10-15. The output circuit configuration of the measurement result output signal is shown in Figure 10-12, and the output circuit configuration of the control output signal is shown in Figure 10-13.

Table 10-15 DC Isolation Output Electrical Characteristics

Output Signal	Output Rated Voltage		Maximum Current	Reference Ground for the Circuit
	LOW	HIGH		
Comparison Signal: <ul style="list-style-type: none"> <li>• /NS1 ~ /NS30</li> <li>• /PASS</li> <li>• /FAIL</li> </ul>	≤ 0.5 V	+5 V ~ +24 V	50 mA	Internal Pull-Up Voltage: <ul style="list-style-type: none"> <li>• ST2840 GND</li> <li>• External Voltage: GND_EXT</li> </ul>
Control Signal: <ul style="list-style-type: none"> <li>• /TEST</li> </ul>				Internal Pull-Up Voltage: <ul style="list-style-type: none"> <li>• ST2840 GND</li> <li>• External Voltage: GND_EXT</li> </ul>



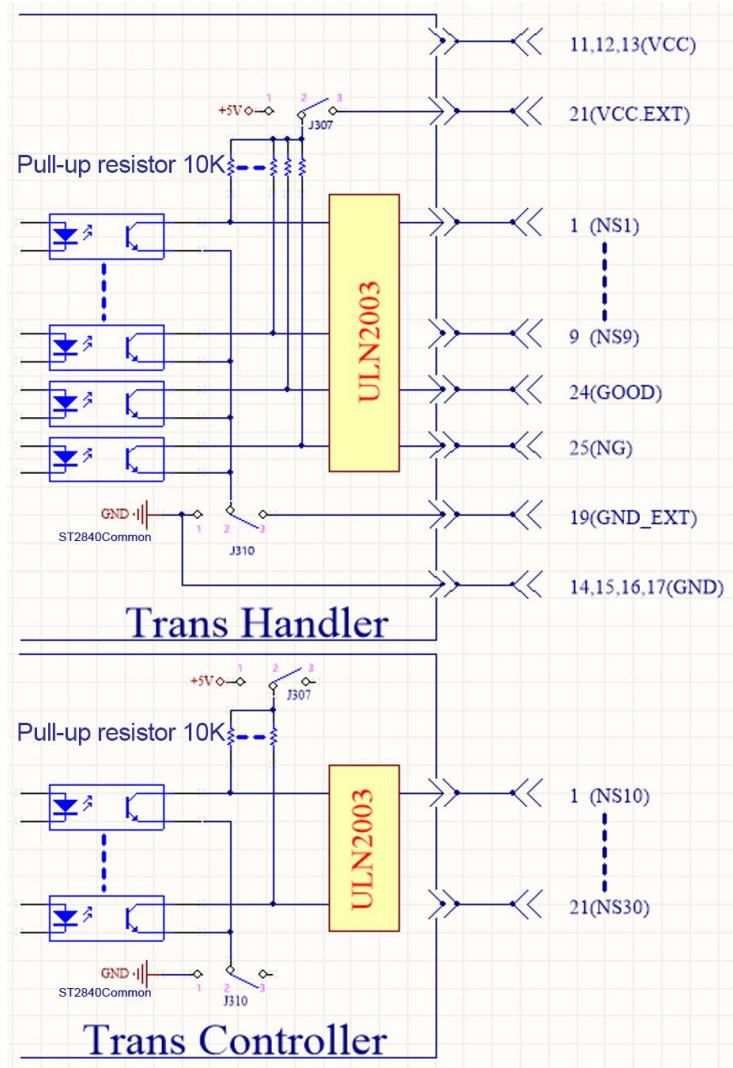

Figure 10-12 Comparison Result Signal Output Circuit

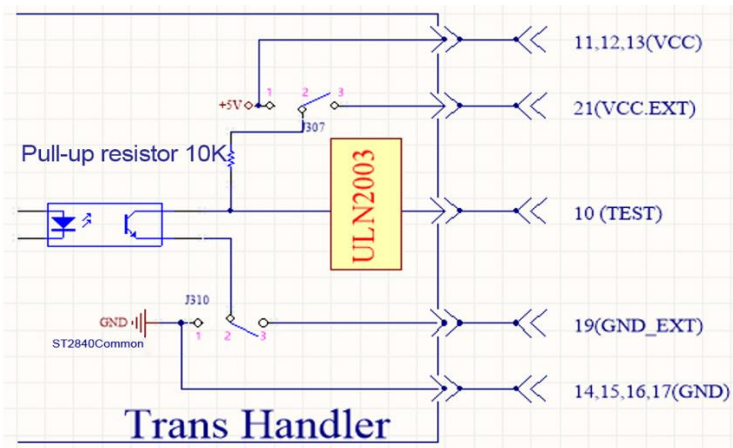

Figure 10-13 Control Signal Output Circuit

### 10.4.2.2 DC Isolation Input Signal

DC isolation input signals include EXT\_RESET and EXT\_START signals.

The EXT\_RESET signal (pin 22 of the Trans Handler) is input to the optocoupler LED (on the cathode side). As long as this is at low level, the keys on the front panel of the instrument will all be locked. The optocoupler LED (anode side) can be driven by internal voltage (+5 V) or external voltage (EXT\_VCC).

The EXT\_START signal (pin 23 of the Trans Handler) is input to the LED cathode side of the optocoupler. The instrument is triggered when the signal increases from LOW to HIGH. The optocoupler LED (anode side) can be driven by an internal pull-up voltage (+5 V) or an external voltage (EXT\_VCC).

The input circuit configuration of the DC isolated input signal is shown in Figure 10-14.

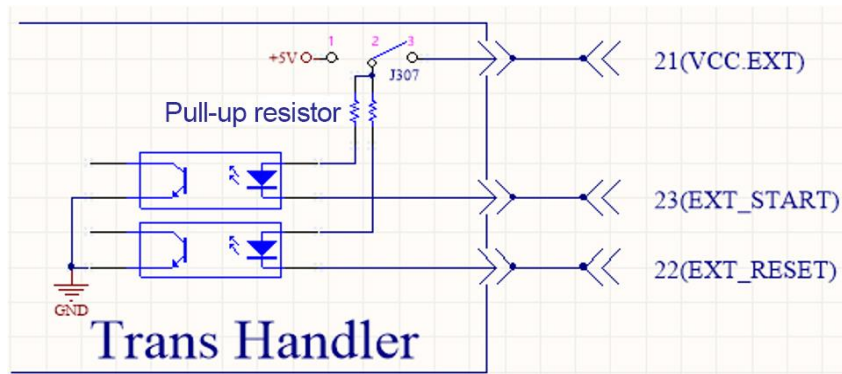

Figure 10-14 Control Input Circuit

### 10.4.3 Wiring Instructions for the Transformer Scan

This section focuses on the example of wiring between the sorting interface of ST2840 transformer scanning and a typical PLC. The wiring example only introduces the wiring of two PLCs, that is, the PLC input circuit common anode and the PLC input circuit common anode. For PLCs with other types of input circuits, please consult customer service.

The PLC input circuit common anode means that the current flows in from the common terminal of the module and flows out from the input channel of the module, which is often referred to as the source wiring method.

The PLC input circuit common cathode means that the current flows in from the input channel of the module and flows out from the common terminal of the module, which is often referred to as the drain wiring method.

When using transformer scanning and sorting, PLC wiring diagram where handler interface and input circuit are common anode is shown in Figure 10-15 and PLC wiring diagram where handler interface and input circuit are common cathode is shown in Figure 10-16.

The factory default of ST2840 series instrument is external power supply. That is, pins 2 and 3 of J307 are short-circuited, pins 2 and 3 of J310 are short-circuited, JP501 is open, and JP503 is open. Therefore, be sure to connect the power supply to the external power supply pin when using it.

If you need to use the internal power supply of the instrument, you need to change the jumper mode of J307 and J310. Please consult our customer support for further details.

<b>Warning!</b>	
	<p>11, 12, 13 of Trans Handler and 22, 23 of Trans Controller are the 5 V power supply inside the instrument and cannot be connected to any external power supply, otherwise the instrument will get damaged.</p> <p>Considering the anti-interference ability of the instrument, it is recommended to provide and use an external power supply as the pull-up power supply of ULN2003.</p>

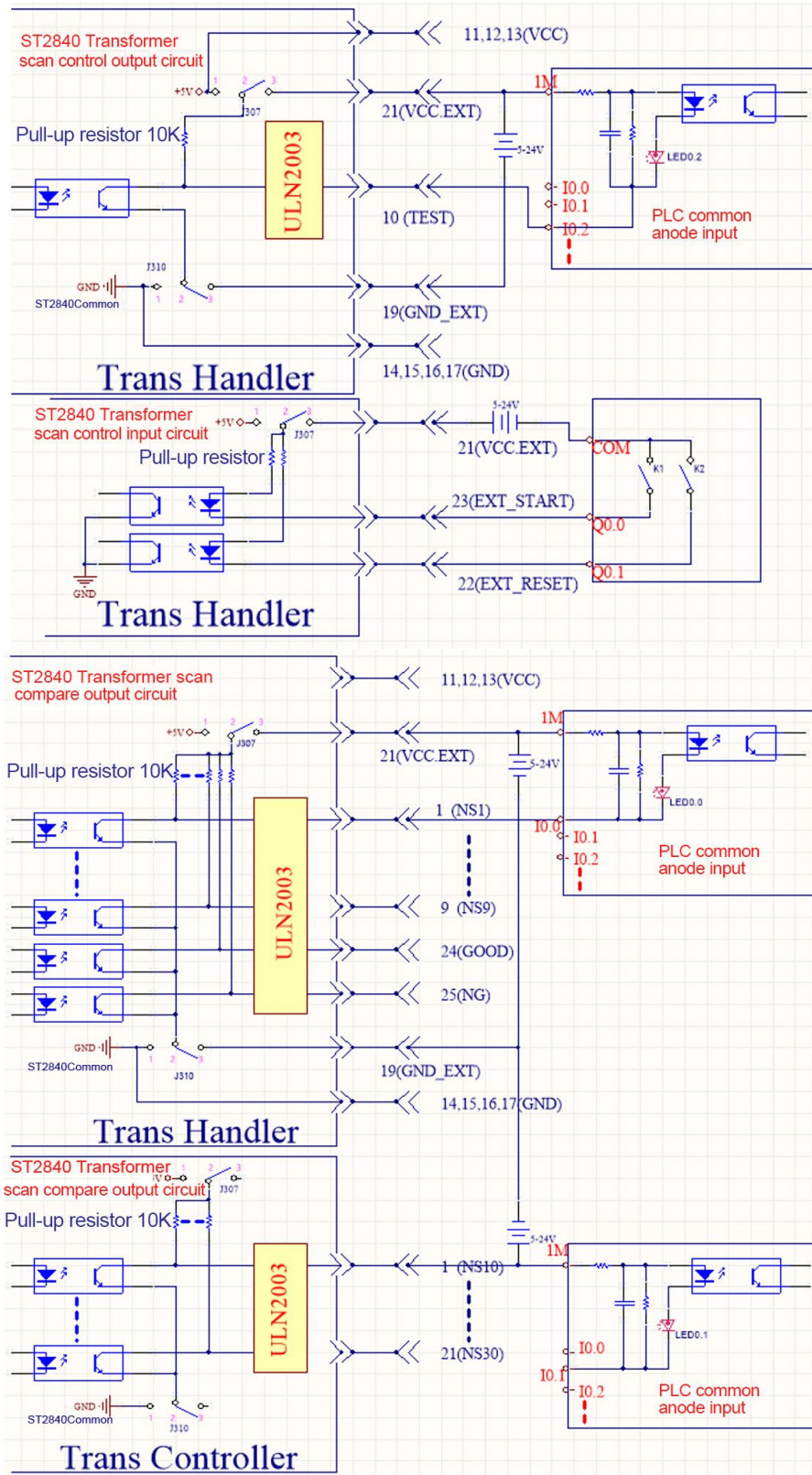

Figure 10-15 PLC Wiring Diagram Where Handler Interface and Input Circuit are Common Anode

The wiring method provided in this figure is a typical connection method, and it needs to be flexibly applied according to the actual situation in practical application.

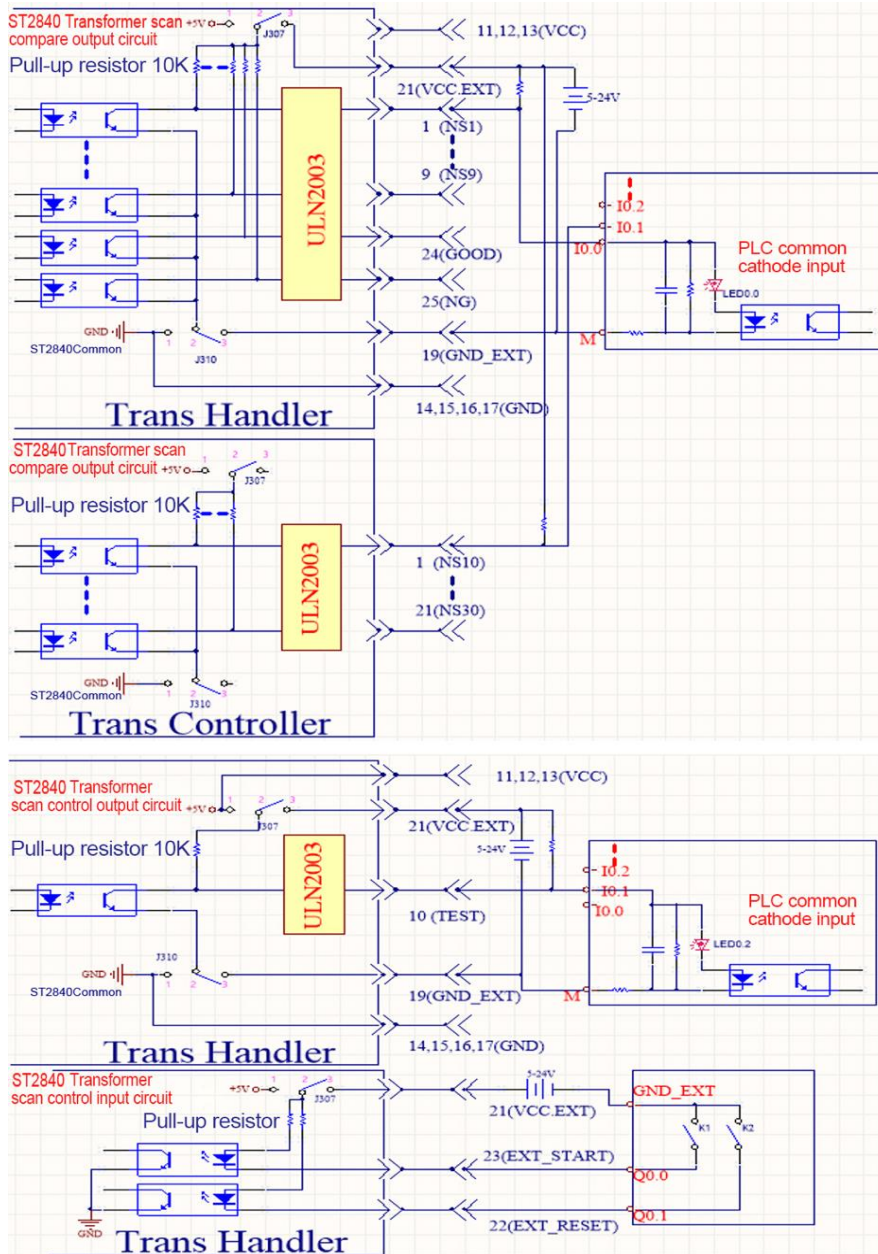

Figure 10-16 PLC Wiring Diagram Where Handler Interface and Input Circuit are Common Cathode

## 10.4.4 Using the Transformer Scan Function

Transformer scan sorting is always on. The sorting modes are default, X12, and X30.

### 10.4.4.1 Sorting Mode Setup

After entering the Transformer Scan mode, press [SETUP], and click [Handler Mode] in the menu bar on the right side of the display screen to enter the <Handler Mode> page.

There are also pin definitions corresponding to the different handler modes on this page.

## 10.5 Sorting of Scanning Fixtures

ST2840AX, ST2840BX and ST2840NX are compatible with ST1901, ST1831, ST1806 series scan boxes.

The ST1831 scan box pin definition is exactly the same as the Handler definition of the ST2840 built-in scan board.



SOURCETRONIC GMBH  
Fahrenheitstrasse 1  
28359 Bremen  
Germany

T +49 421 2 77 99 99  
F +49 421 2 77 99 98  
info@sourcetric.com  
www.sourcetric.com

CE